



V210R

Technical Data | Imperial



46.295 lb

MAX PAYLOAD

Portata massima / Capacité max
Max Tragfähigkeit / Max capacidad

V210R

TECHNICAL INFORMATION AND OVERALL SIZE

Informazioni tecniche e dimensioni d'ingombro
Informations techniques et dimensions globales
Technische Informationen und Gesamtgröße
Información técnica y dimensiones totales

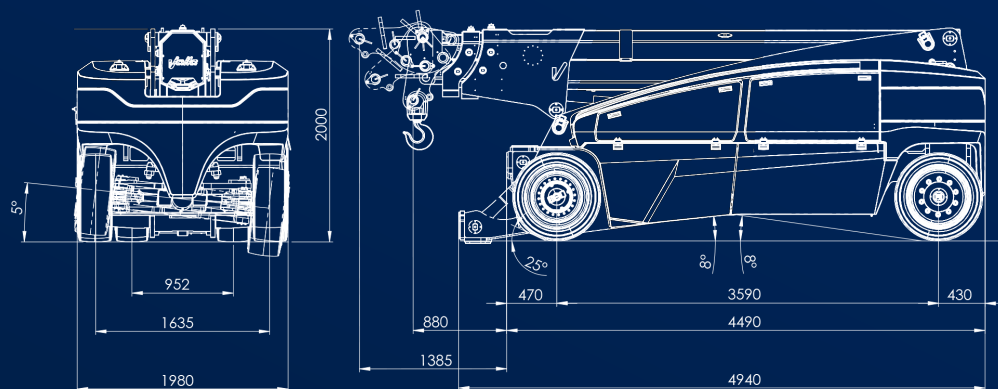

MAX PAYLOAD

Portata massima / Capacité max
Max Tragfähigkeit / Max capacidad

46.295 lb

TOTAL WEIGHT

Peso totale / Poids total
Gesamtgewicht / Peso total

51.300 lb

DIMENSIONS

Dimensioni / Dimensions
Abmessungen / Dimensiones

175 x 80 x 75 in

FRONT

Anteriore / Avant / Vorderrad / Delantera

N° 4 / 355/50 – 20"

REAR

Posteriore / Arrière / Hinterrad / Trasera

N° 2 / 355/50 – 20"

HYDRAULICS

Impianto idraulico (Pressione massima/Potenza motore)
Hydraulique (Pression maxi/Puissance moteur)
Hydraulik (Max Druck/Motorleistung)
Hidraulica (Presion max/Potencia motor)

220 Bar – 33 kW AC

FRONT-WHEEL DRIVE

Trazione anteriore / Traction avant
Frontantrieb / Tracción delantera

2 x 7.5 kW AC

REAR STEERING

Sterzata posteriore / Direction arrière
Hintere Lenkung / Direccion trasera

+/-90°

BATTERY

Batteria / Batterie / Batterie / Batterie

96V - 1.050 Ah

REMOVABLE COUNTERWEIGHTS

Contrappesi removibili / Contrepoids amovibles
Abnehmbare Gegengewichte / Contrapesos removibles

N° 3 x 4.895 lb

FRONT ELECTRO-HYDRAULIC BRAKES

Freni elettroidraulici anteriori / Freins électrohydrauliques avant
Elektrohydraulische Vorderradbrem sen / Frenos electrohidráulicos delanteros

V210R

MAXIMUM PERFORMANCE AND EQUIPMENTS

Massime prestazioni ed equipaggiamenti
Performances maximales et équipements
Maximale Leistung und Ausrüstung
Máximas prestaciones y equipamiento

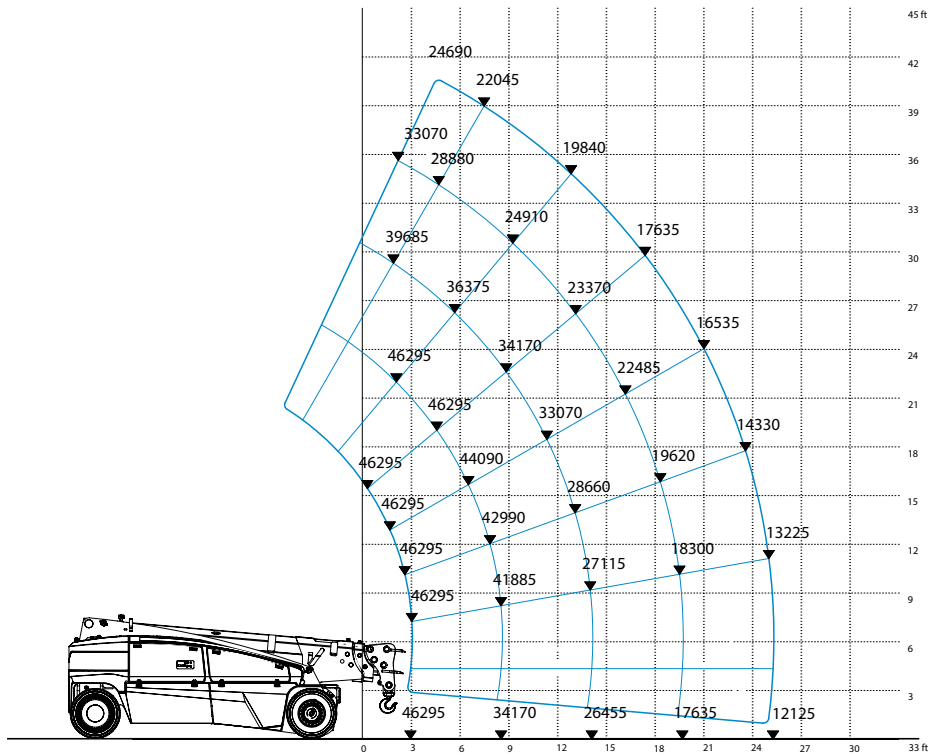

REFERENCE STANDARDS

Normative di riferimento / Normes de référence
Referenzstandards / Estandards de referencia

2006/42 CE
EN 13000

STANDARD

NON-MARKING TIRES

Ruote anti traccia / Roues anti-traces
Nicht-markierende Räder / Ruedas anti-marcas

VARIABLE TILT HEAD

Testa ad inclinazione variabile / Tête à inclinaison variable
Abwinkelbare Spitze / Cabezal ajustable

RADIO-CONTROL

Radiocomando / Radiocommande / Fernsteuerung / Radio control

HOOK

Gancio / Crochet / Haken / Gancho

STABILIZER CROSSBAR

Barra stabilizzatrice anteriore / Barre stabilisatrice
Vorderradabstützung / Barra estabilizadora

WINCH

Argano / Treuil / Winde / Cabrestante

FIXED MECHANICAL JIB

Jib meccanico non ripiegabile / Fléchette mécanique non repliable
Feste mechanische Spitze / Pluma mecanica no plegable

FOLDABLE HYDRAULIC JIB

Jib idraulico ripiegabile / Fléchette hydraulique repliable
Klappbarer hydraulischer Ausleger / Pluma hidráulica plegable

FOLDABLE TELESCOPIC HYDRAULIC JIB

Jib idraulico telescopico ripiegabile / Fléchette hydraulique télescopique repliable
Faltbarer teleskopischer hydraulischer jib/ Pluma hidráulica telescópica plegable

SELF-LEVELLING FORKS

Forche autolivellanti / Fourches à nivellement automatique
Selbstnivellierende Gabeln / Horquillas autonivelantes

LITHIUM BATTERIES

Batterie al litio / Batteries au lithium
Lithiumbatterien / Baterías de litio

ATEX TRANSFORMATION

Trasformazione ATEX / Transformation ATEX
ATEX-Umwandlung / Transformación ATEX

VALLA CONNECT SYSTEM

OPTIONAL

info.valla@tadano.com

www.tadano.com

Tadano Ltd.

Kanda Square 18th Floor, 2-2-1 Kanda-Nishikicho, Chiyoda-ku, Tokyo 101-0054, Japan

Phone: +81-3-6811-7309 (International Division)

Manitex Valla S.R.L.

Via Leonardo da Vinci, 12 29016 - Careco - Piacenza - Italia.

Tel.: +39 0523 256411



Reaching new heights

