



V80R

Technical Data | Metric



8 t

MAX PAYLOAD

Portata massima / Capacité max

Max Tragfähigkeit / Max capacidad

V80R

TECHNICAL INFORMATION AND OVERALL SIZE

Informazioni tecniche e dimensioni d'ingombro
Informations techniques et dimensions globales
Technische Informationen und Gesamtgröße
Información técnica y dimensiones totales

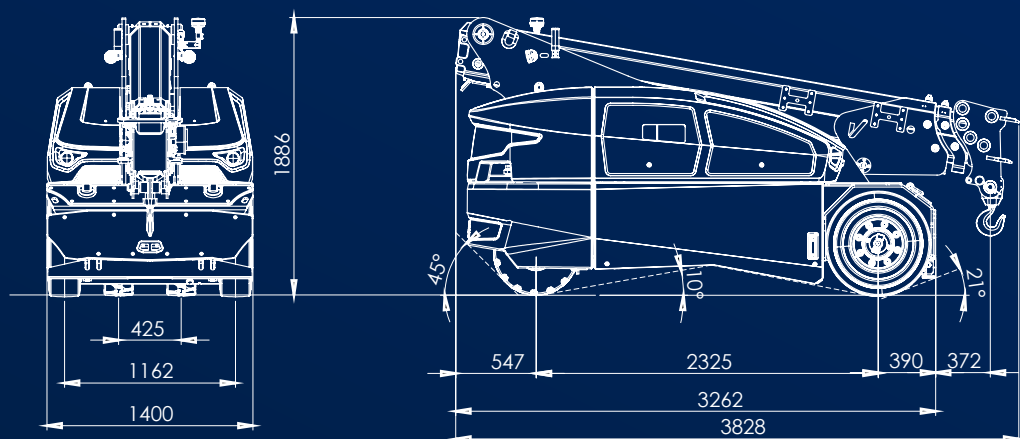

MAX PAYLOAD

Portata massima / Capacité max
Max Tragfähigkeit / Max capacidad

8.000 kg

TOTAL WEIGHT

Peso totale / Poids total
Gesamtgewicht / Peso total

8.350 kg

DIMENSIONS

Dimensioni / Dimensions
Abmessungen / Dimensiones

3190 x 1400 x 1895 mm

FRONT

Anteriore / Avant / Vorderrad / Delantera

N° 2 S.E. / 250 – 15"

REAR

Posteriore / Arrière / Hinterrad / Trasera

N° 2 S.E. / 23x9 – 10"

HYDRAULICS

Impianto idraulico (Pressione massima/Potenza motore)
Hydraulique (Pression maxi/Puissance moteur)
Hydraulik (Max Druck/Motorleistung)
Hidraulica (Presion max/Potencia motor)

220 Bar – 12 kW AC

FRONT-WHEEL DRIVE

Trazione anteriore / Traction avant
Frontantrieb / Tracción delantera

2 x 4.2 kW AC

REAR STEERING

Sterzata posteriore / Direction arrière
Hintere Lenkung / Dirección trasera

800W AC - 180°

BATTERY

Batteria / Batterie / Batterie / Batterie

80V - 560 Ah

COUNTERWEIGHTS

Contrappeso / Contrepoids
Gegengewichte / Contrapesos

N° 2 x 1.300 kg

ELECTRO-HYDRAULIC BRAKES

Freni elettroidraulici / Freins électrohydrauliques
Elektrohydraulische Bremsen / Frenos electrohidráulicos

info.valla@tadano.com

www.tadano.com

Tadano Ltd.

Kanda Square 18th Floor, 2-2-1 Kanda-Nishikicho, Chiyoda-ku, Tokyo 101-0054, Japan

Phone: +81-3-6811-7309 (International Division)

Manitex Valla S.R.L.

Via Leonardo da Vinci, 12 29016 - Careco - Piacenza - Italia.

Tel.: +39 0523 256411



Reaching new heights

