



PRODUCT DETAILS

Documentazione tecnica / Détails du produit
Produktdetails/ Detalles de producto

V180RC

TECHNICAL INFORMATION

Informazioni tecniche
Informations techniques
Technische information
Información técnica

MAX PAYLOAD

Portata massima / Capacité max
Max Tragfähigkeit / Max capacidad

18.000 kg

TOTAL WEIGHT

Peso totale / Poids total
Gesamtgewicht / Peso total

20.750 kg

DIMENSIONS

Dimensioni / Dimensions
Abmessungen / Dimensiones

4.540 x 2.000 x 1.980 mm

FRONT

Anteriore / Avant / Vorderrad / Delantera

N° 4 S.E. 355/50 – 20”

REAR

Posteriore / Arrière / Hinterrad / Trasera

N° 2 S.E. 355/50 – 20”

HYDRAULICS

Impianto idraulico (Pressione massima/Potenza motore)
Hydraulique (Pression maxi/Puissance moteur)
Hydraulik (Max Druck/Motorleistung)
Hidraulica (Presion max/Potencia motor)

220 Bar – 33 kW AC

FRONT-WHEEL DRIVE

Trazione anteriore / Traction avant
Frontantrieb / Tracción delantera

2 x 7.5 kW AC

REAR STEERING

Sterzata posteriore / Direction arrière
Hintere Lenkung / Dirección trasera

+/-90°

BATTERY

Batteria / Batterie / Batterie / Batterie

96V - 1.050 Ah

REMOVABLE COUNTERWEIGHTS

Contrappesi removibili / Contrepoids amovibles
Abnehmbare Gegengewichte / Contrapesos removibles

N° 3 x 6.500 kg tot.

FRONT ELECTRO-HYDRAULIC BRAKES

Freni elettroidraulici anteriori / Freins électrohydrauliques avant
Elektrohydraulische Vorderradbrem sen / frenos electrohidráulicos delanteros

V180RC

EQUIPMENTS

Equipaggiamenti
Équipements
Ausrüstung
Equipamiento

STANDARD

CLOSED CABIN

Cabina chiusa / Cabine fermée / Geschlossene Kabine / Cabina cerrada

NON-MARKING TIRES

Ruote anti traccia / Roues anti-traces
Nicht-markierende Räder / Ruedas anti-marcas

VARIABLE TILT HEAD

Testa ad inclinazione variabile / Tête à inclinaison variable
Abwinkelbare Spitze / Cabezal ajustable

RADIO-CONTROL

Radiocomando / Radiocommande / Fernsteuerung / Radio control

HOOK

Gancio / Crochet / Haken / Gancho

OPTIONAL

WINCH

Argano / Treuil / Winde / Cabrestante

FRONT STABILIZER

Stabilizzatori anteriori / Stabilisateur avant
Frontstabilisator / Estabilizador delantero

FIXED MECHANICAL JIB

Jib meccanico non ripiegabile / Fléchette mécanique non repliable
Feste mechanische Spitze / Pluma mecanica no plegable

FOLDABLE HYDRAULIC JIB

Jib idraulico ripiegabile / Fléchette hydraulique repliable
Klappbarer hydraulischer Ausleger / Pluma hidráulica plegable

FOLDABLE TELESCOPIC HYDRAULIC JIB

Jib idraulico telescopico ripiegabile / Fléchette hydraulique télescopique repliable
Faltbarer teleskopischer hydraulischer jib/ Pluma hidráulica telescópica plegable

SELF-LEVELLING FORKS

Forche autolivellanti / Fourches à nivellement automatique
Selbstnivellierende Gabeln / Horquillas autonivelantes

LITHIUM BATTERIES

Batterie al litio / Batteries au lithium
Lithiumbatterien / Baterías de litio

ATEX TRANSFORMATION

Trasformazione ATEX / Transformation ATEX
ATEX-Umwandlung / Transformación ATEX

VALLA CONNECT SYSTEM

V180RC

OVERALL SIZE

Dimensioni d'ingombro

Dimensions globales

Gesamtgröße

Dimensiones totales

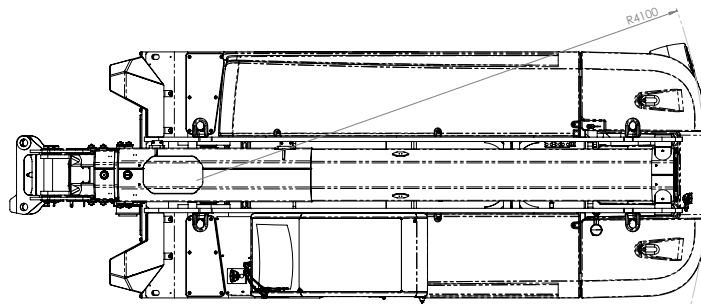
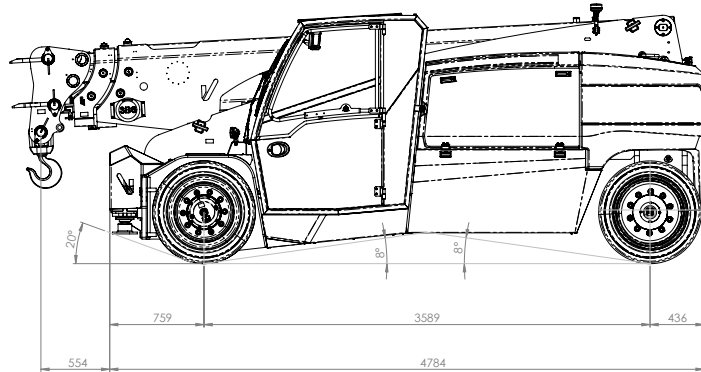
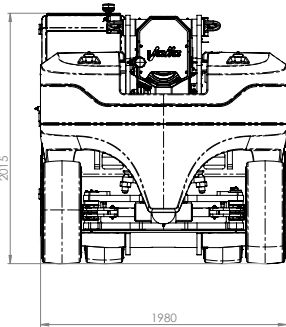
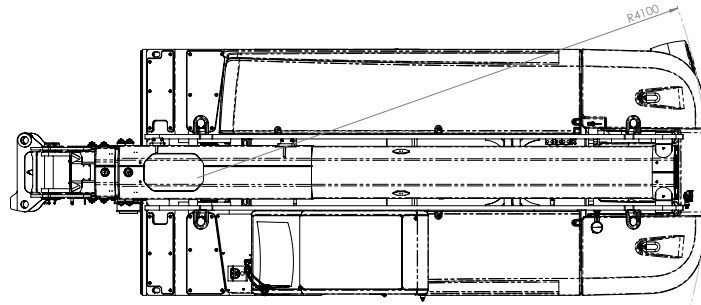
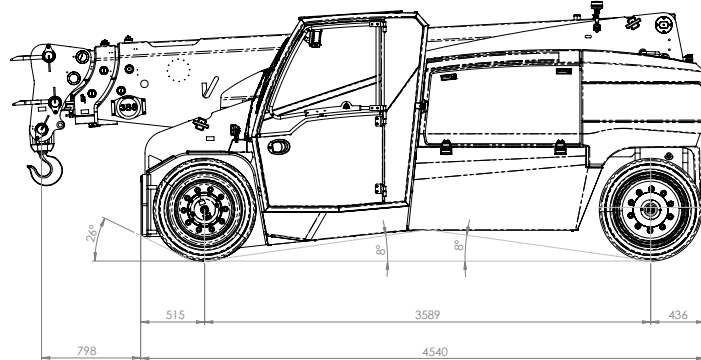
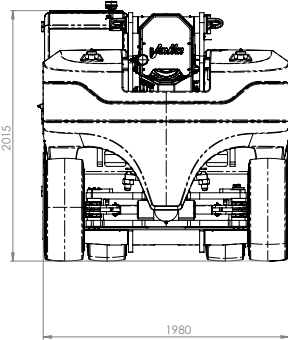

V180RC



OVERALL SIZE

Dimensioni d'ingombro
Dimensions globales
Gesamtgröße
Dimensiones totales

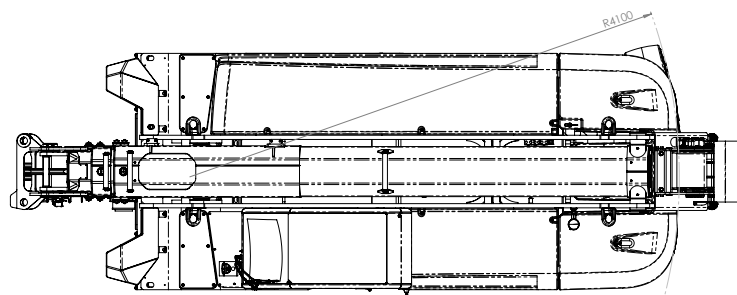
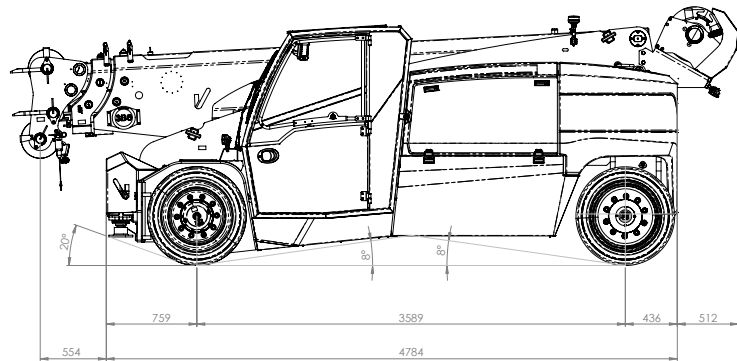
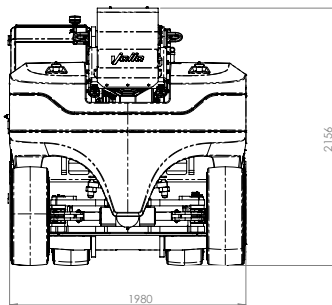
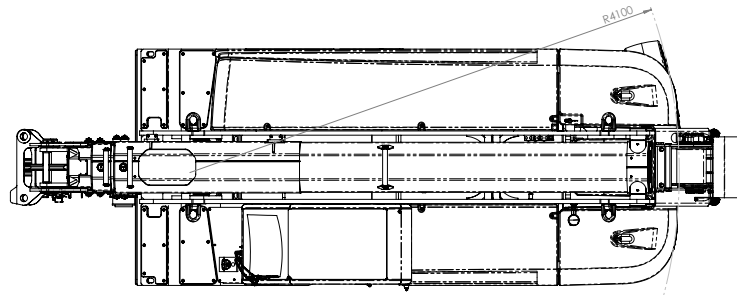
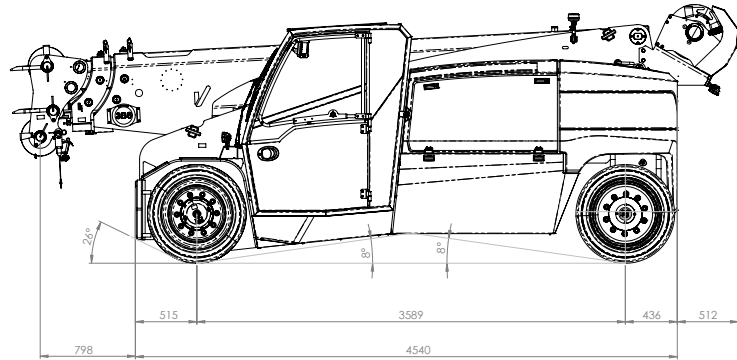
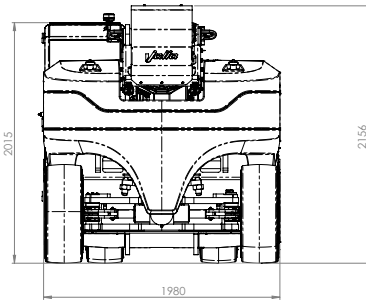

V180RC



OVERALL SIZE

Dimensioni d'ingombro
Dimensions globales
Gesamtgröße
Dimensiones totales

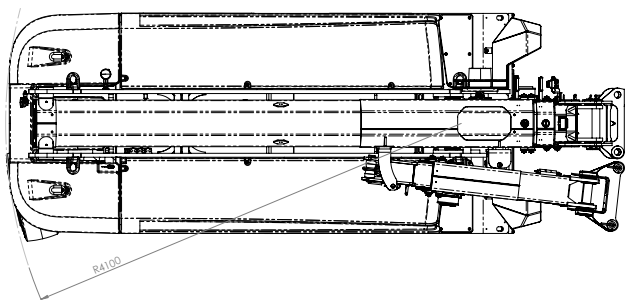
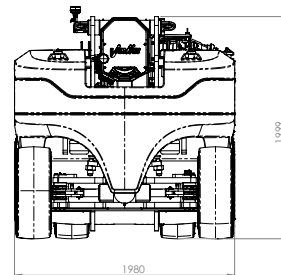
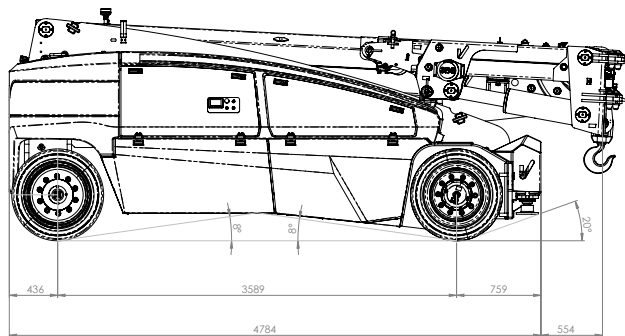
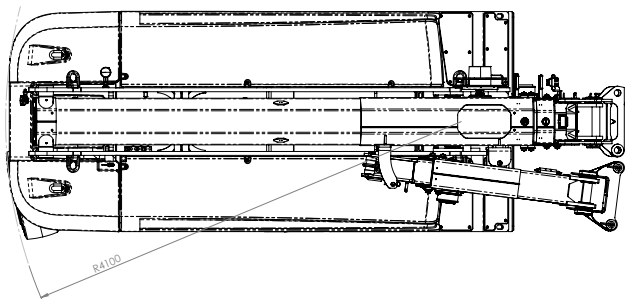
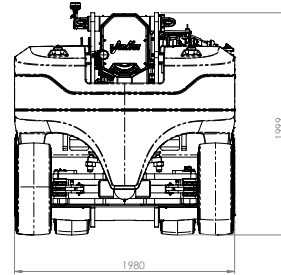
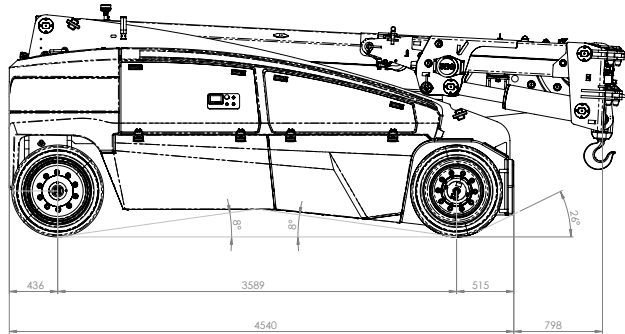

V180RC



OVERALL SIZE

Dimensioni d'ingombro

Dimensions globales

Gesamtgröße

Dimensiones totales

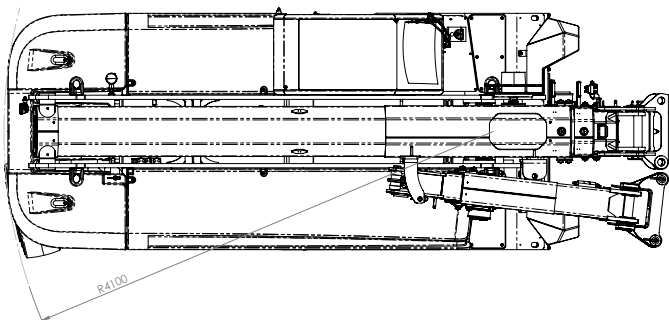
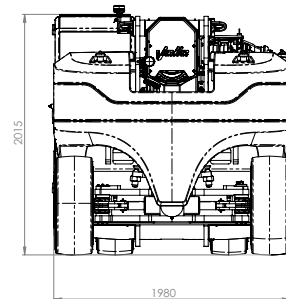
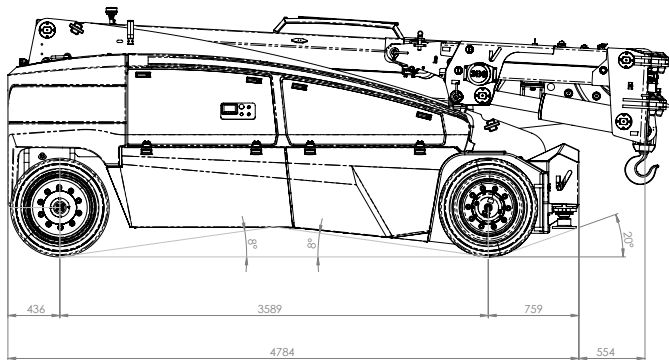
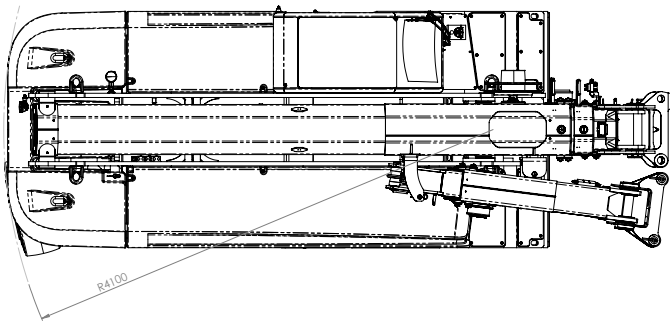
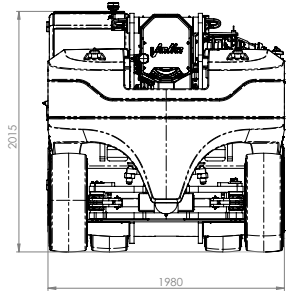
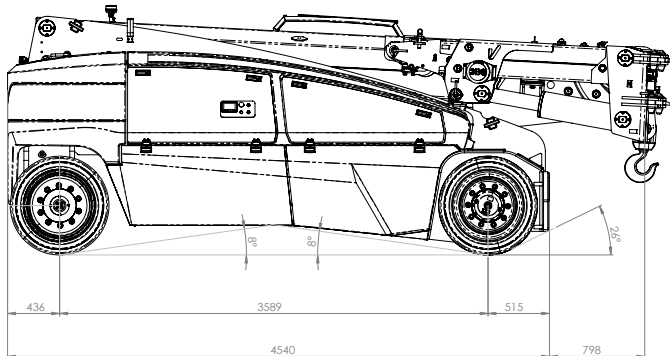

V180RC

OVERALL SIZE

Dimensioni d'ingombro

Dimensions globales

Gesamtgröße

Dimensiones totales

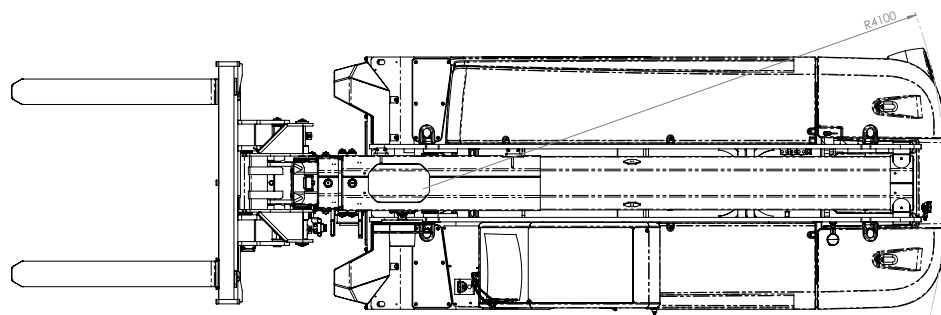
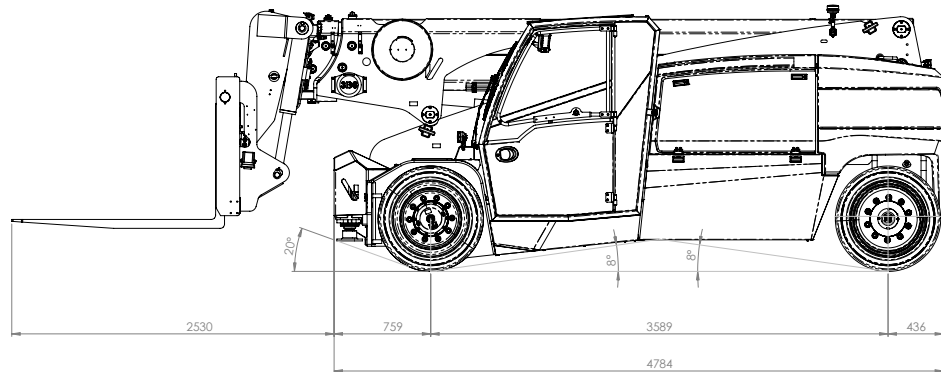
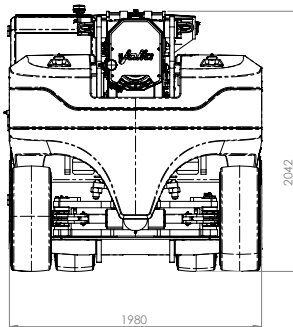
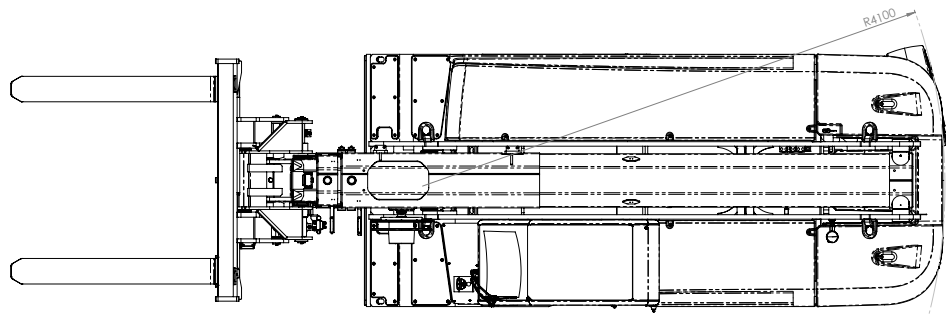
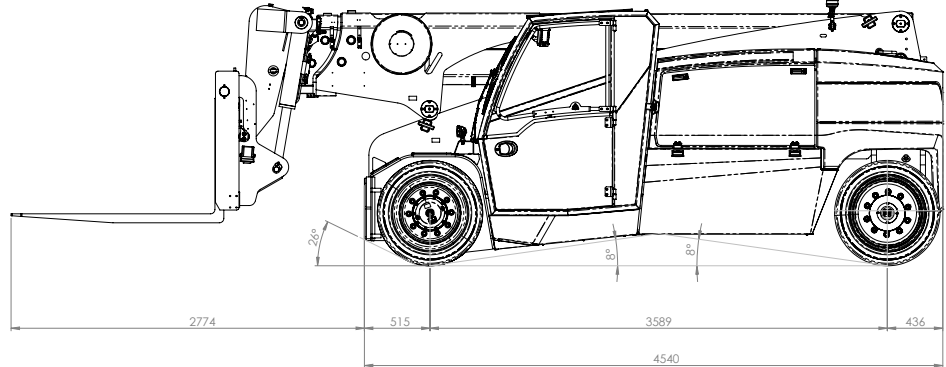
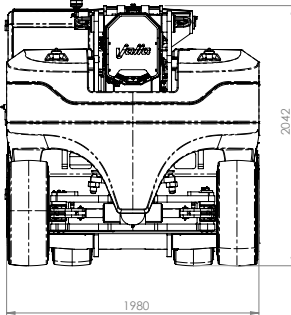

V180RC

LOAD DIAGRAM (t)

Diagramma di carico (t)

Tableau de charges utiles (t)

Traglastdiagramm (t) / Lastendiagramm (t)

Diagrama de las capacidades de carga (t)



POS. 1
COD.188.412.REV.A

UNI EN 13000:2014
ISO 4305:2014

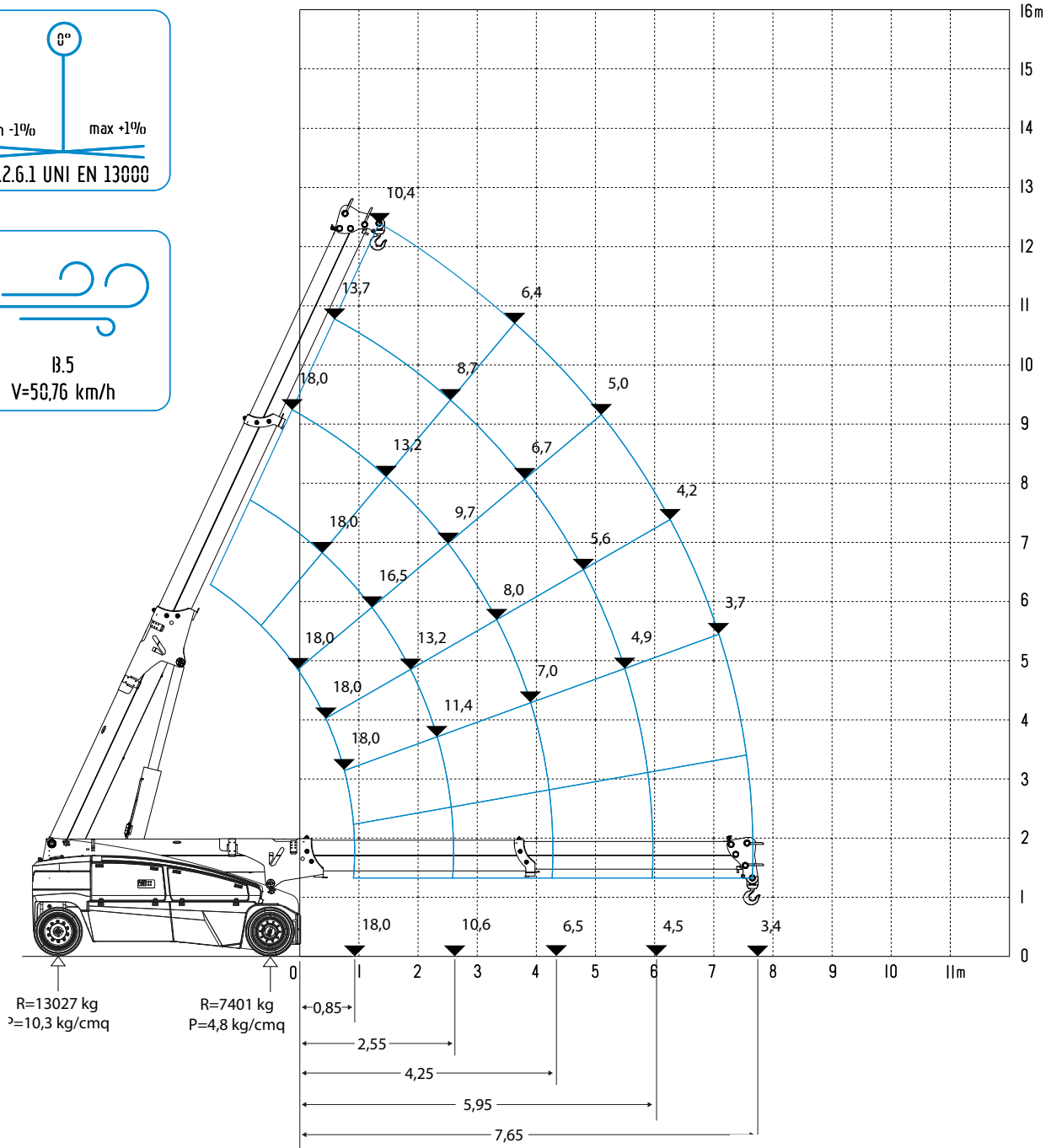
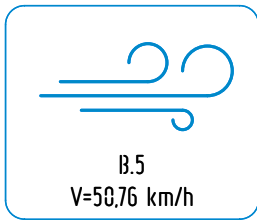
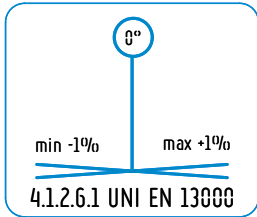

V180RC

LOAD DIAGRAM (t)

Diagramma di carico (t)

Tableau de charges utiles (t)

Traglastdiagramm (t) / Lastendiagramm (t)

Diagrama de las capacidades de carga (t)



POS. 2
COD.188.412.REV.A

UNI EN 13000:2014
ISO 4305:2014

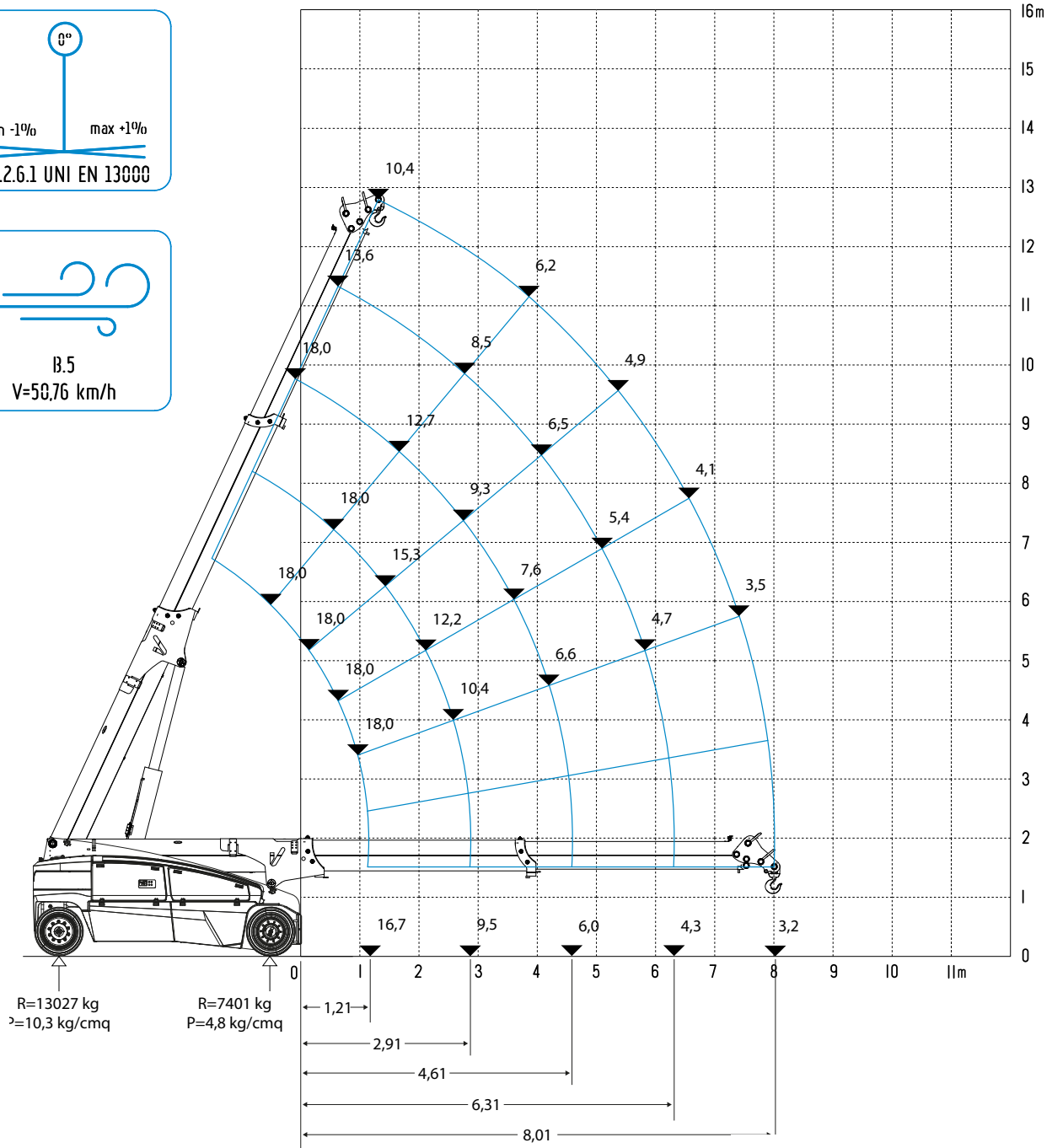
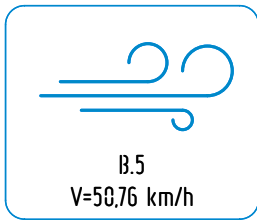
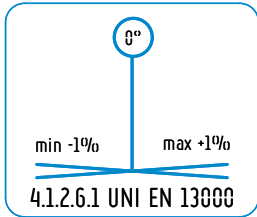

R=13027 kg
P=10,3 kg/cm²

R=7401 kg
P=4,8 kg/cm²

V180RC

LOAD DIAGRAM (t)

Diagramma di carico (t)

Tableau de charges utiles (t)

Traglastdiagramm (t) / Lastendiagramm (t)

Diagrama de las capacidades de carga (t)



POS. 3
COD.188.412.REV.A

UNI EN 13000:2014
ISO 4305:2014

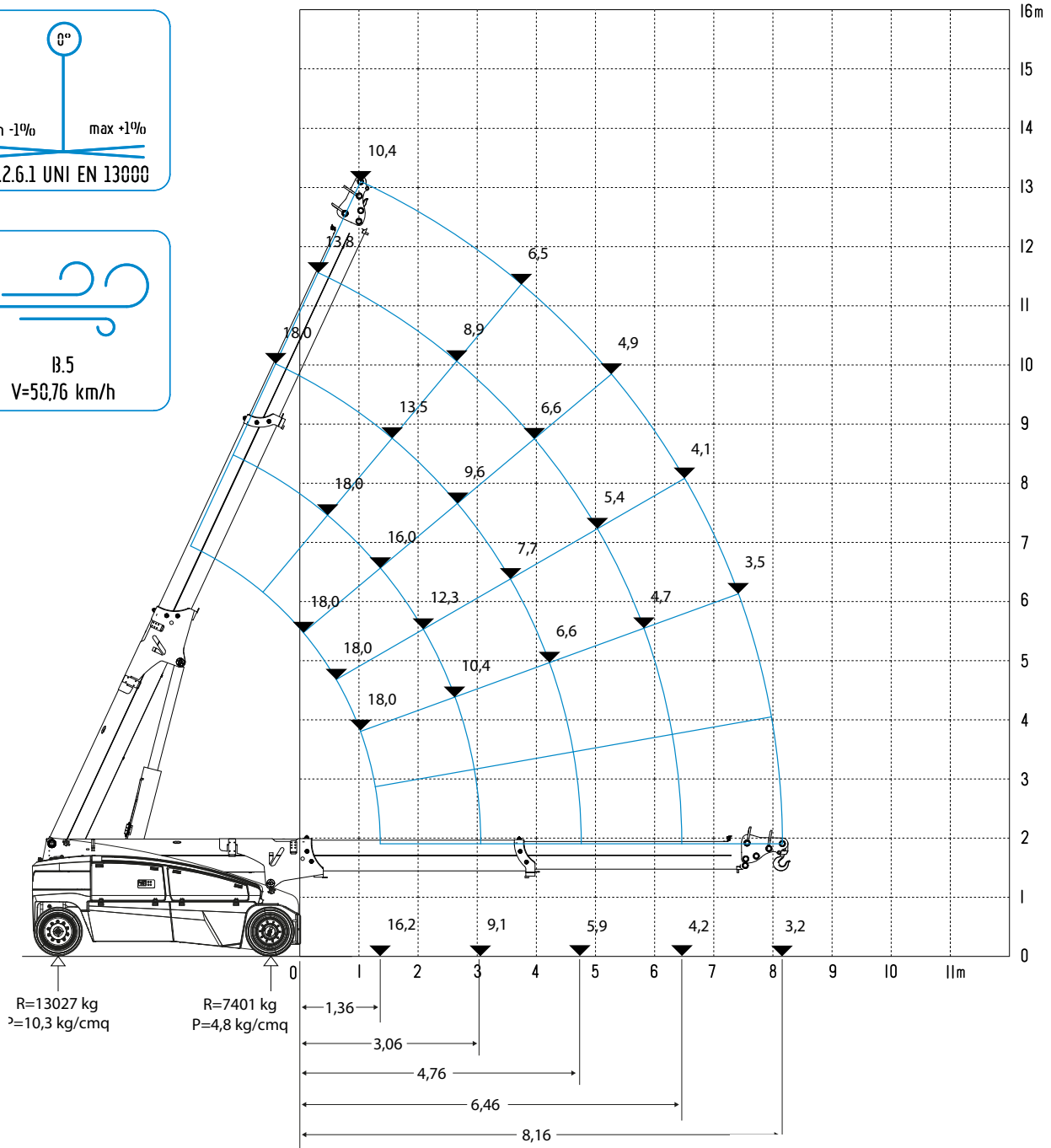
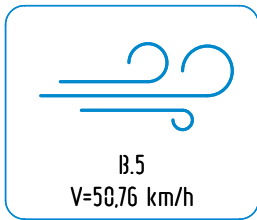
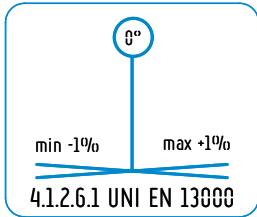

V180RC

LOAD DIAGRAM (t)

Diagramma di carico (t)

Tableau de charges utiles (t)

Traglastdiagramm (t) / Lastendiagramm (t)

Diagrama de las capacidades de carga (t)



COD.188.412.REV.A

UNI EN 13000:2014

ISO 4305:2014

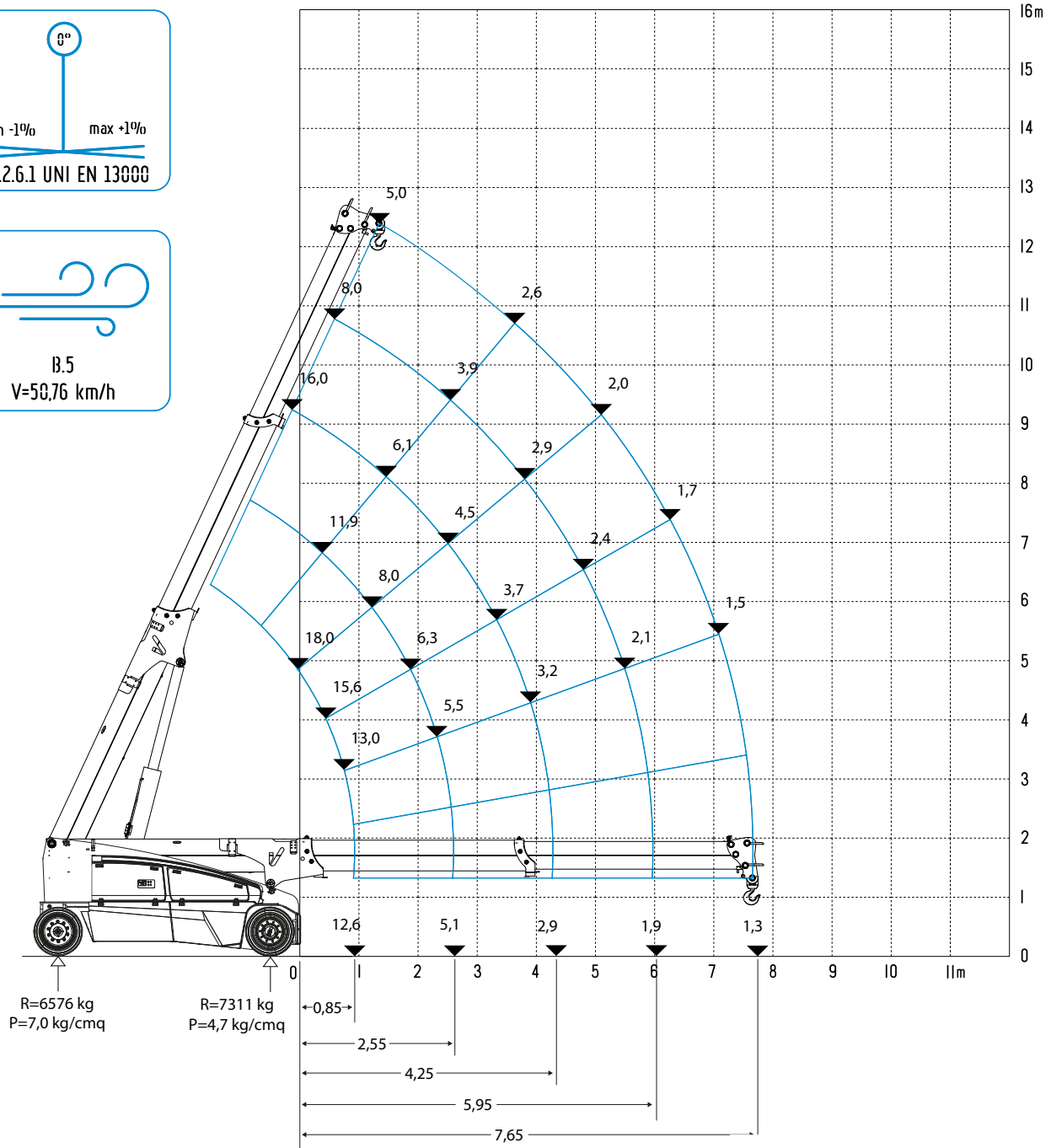
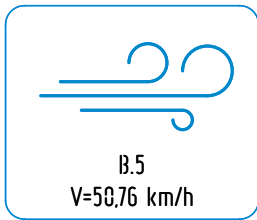
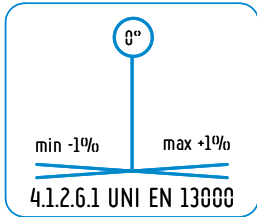

V180RC

LOAD DIAGRAM (t)

Diagramma di carico (t)

Tableau de charges utiles (t)

Traglastdiagramm (t) / Lastendiagramm (t)

Diagrama de las capacidades de carga (t)



POS. 1
COD.188.412.REV.A

UNI EN 13000:2014
ISO 4305:2014

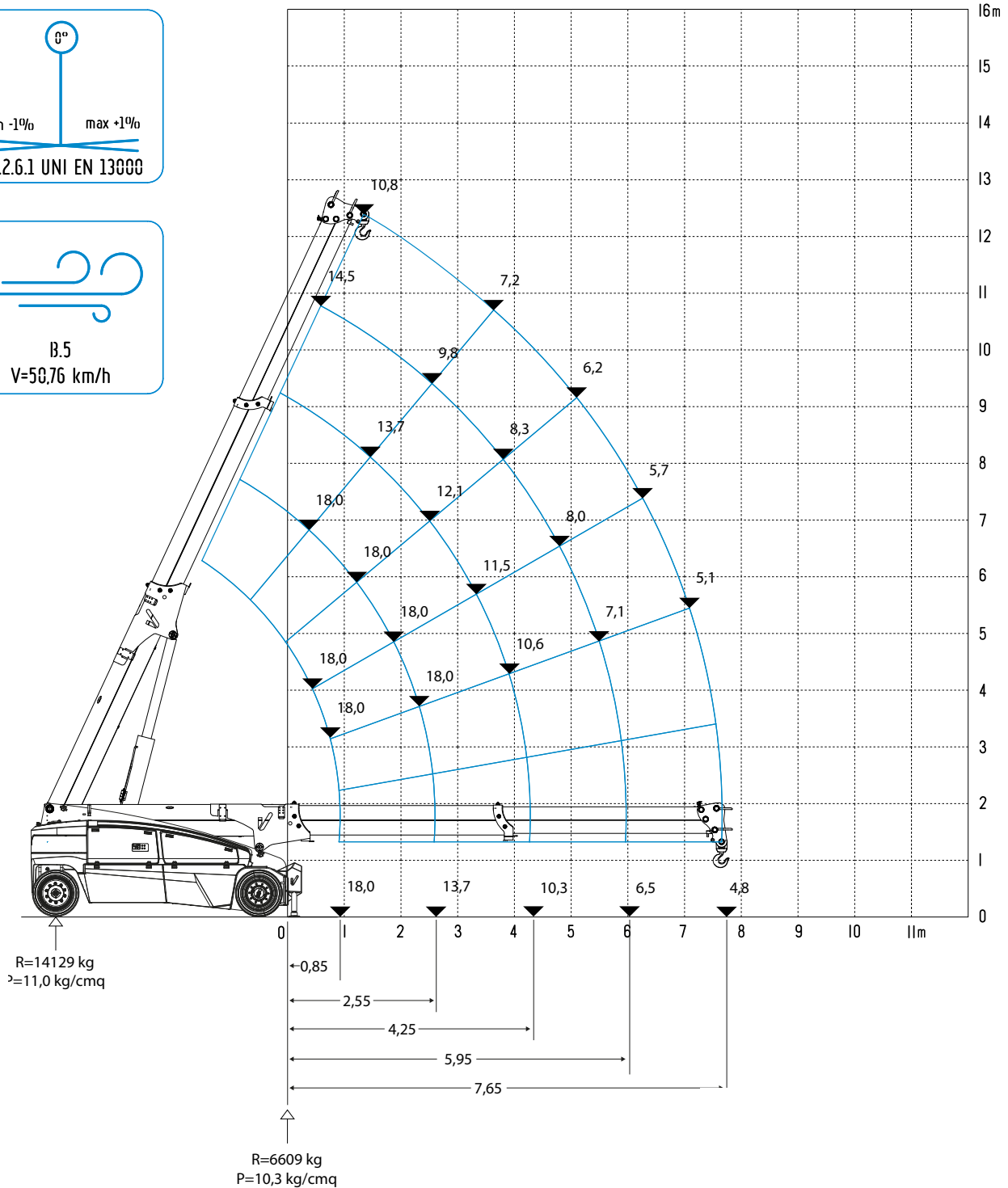
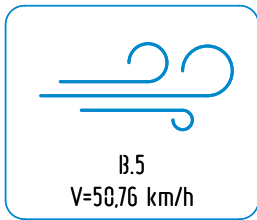
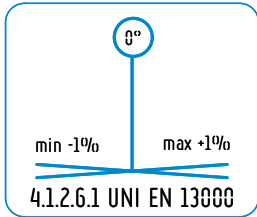

V180RC

LOAD DIAGRAM (t)

Diagramma di carico (t)

Tableau de charges utiles (t)

Traglastdiagramm (t) / Lastendiagramm (t)

Diagrama de las capacidades de carga (t)



POS. 2
COD.188.412.REV.A

UNI EN 13000:2014
ISO 4305:2014

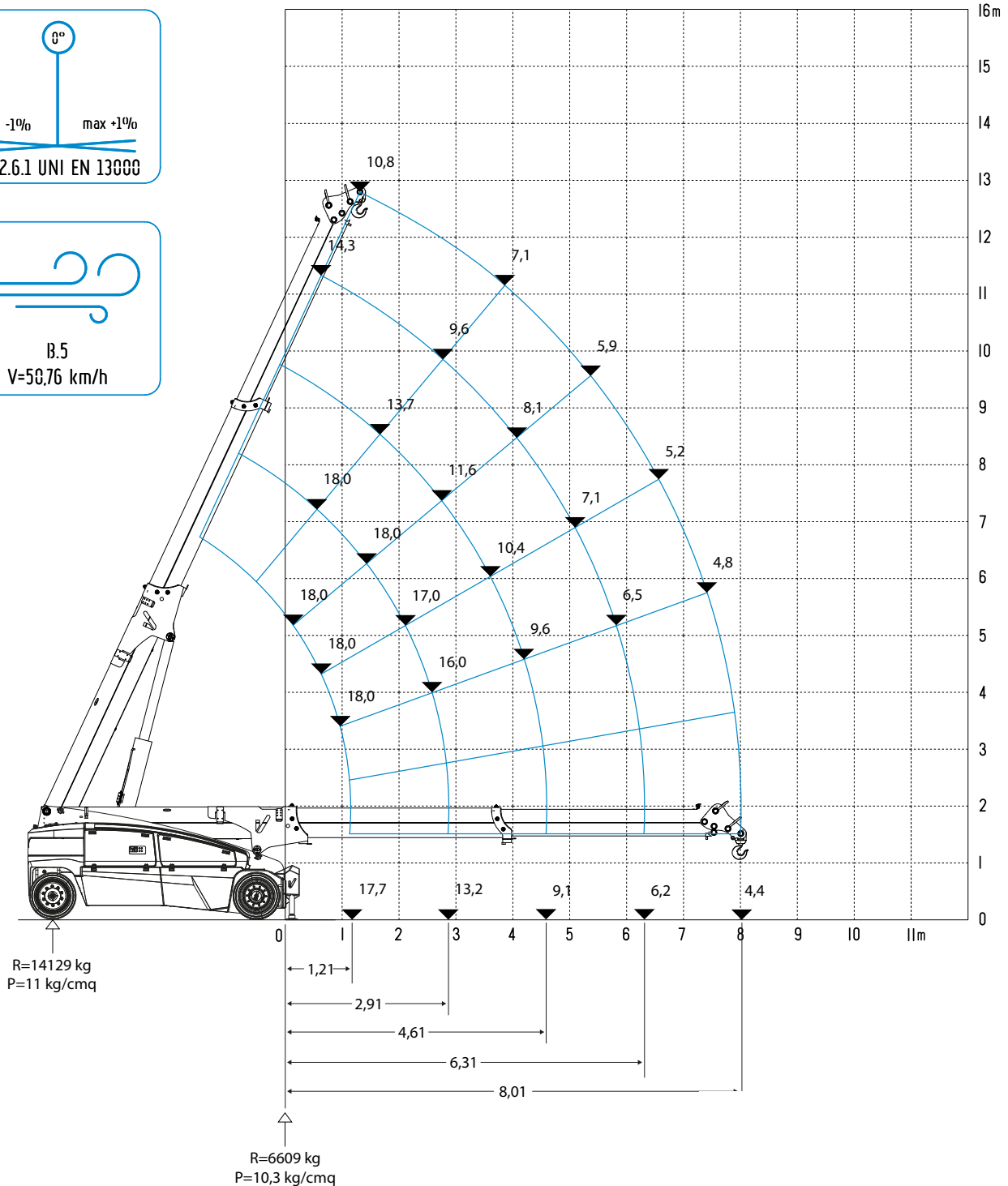
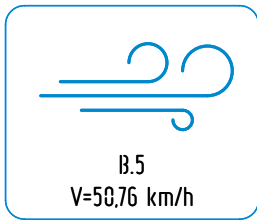
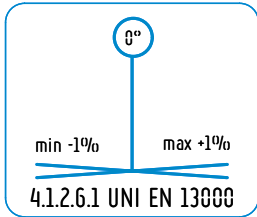

V180RC

LOAD DIAGRAM (t)

Diagramma di carico (t)

Tableau de charges utiles (t)

Traglastdiagramm (t) / Lastendiagramm (t)

Diagrama de las capacidades de carga (t)



POS. 3
COD.188.412.REV.A

UNI EN 13000:2014
ISO 4305:2014

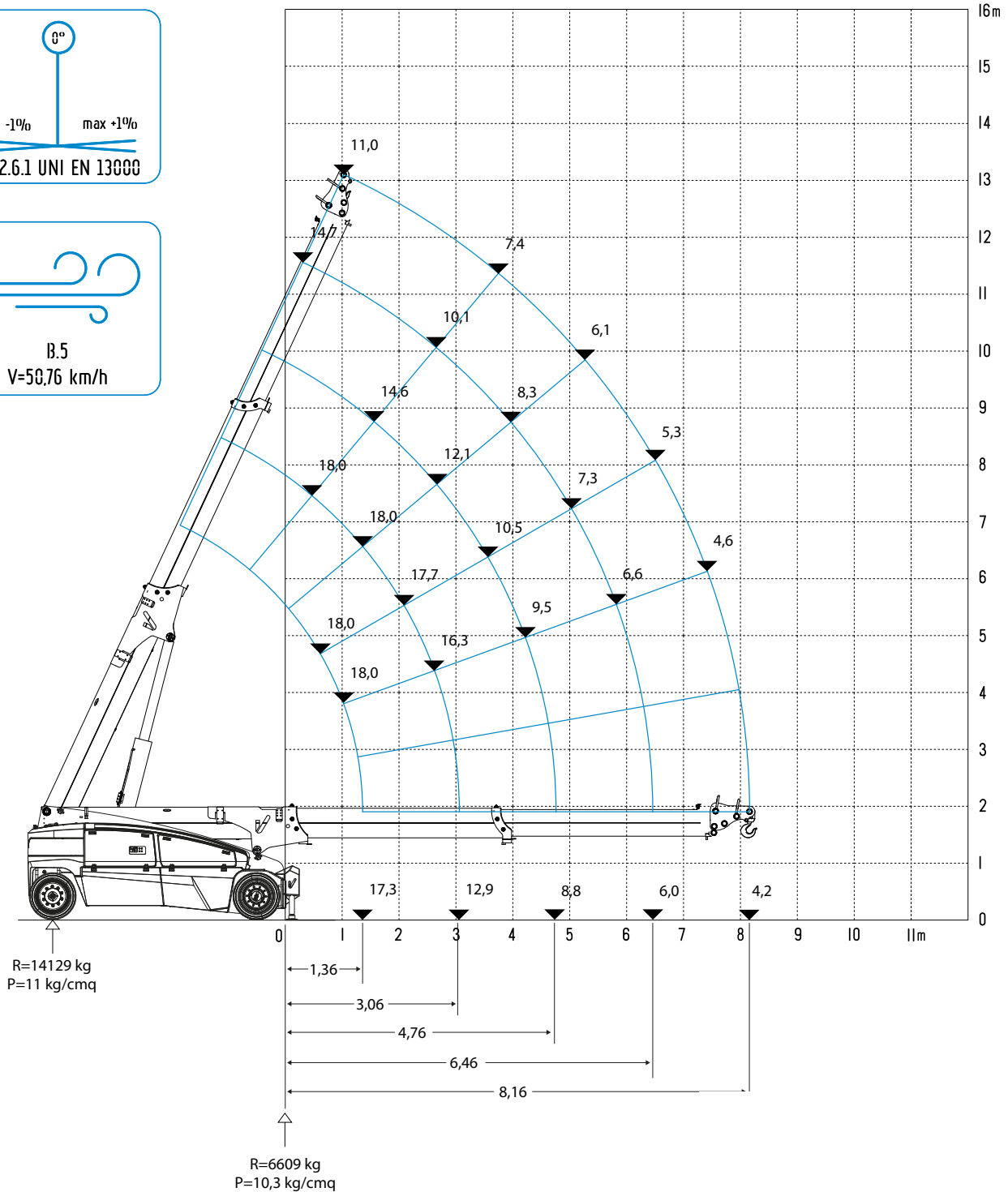
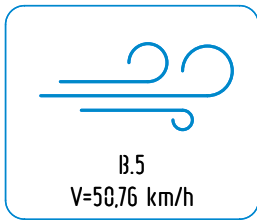
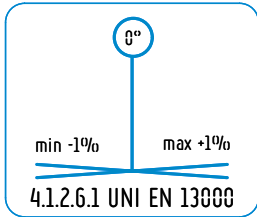

V180RC

LOAD DIAGRAM (t)

Diagramma di carico (t)

Tableau de charges utiles (t)

Traglastdiagramm (t) / Lastendiagramm (t)

Diagrama de las capacidades de carga (t)



COD.188.412.REV.A

UNI EN 13000:2014

ISO 4305:2014

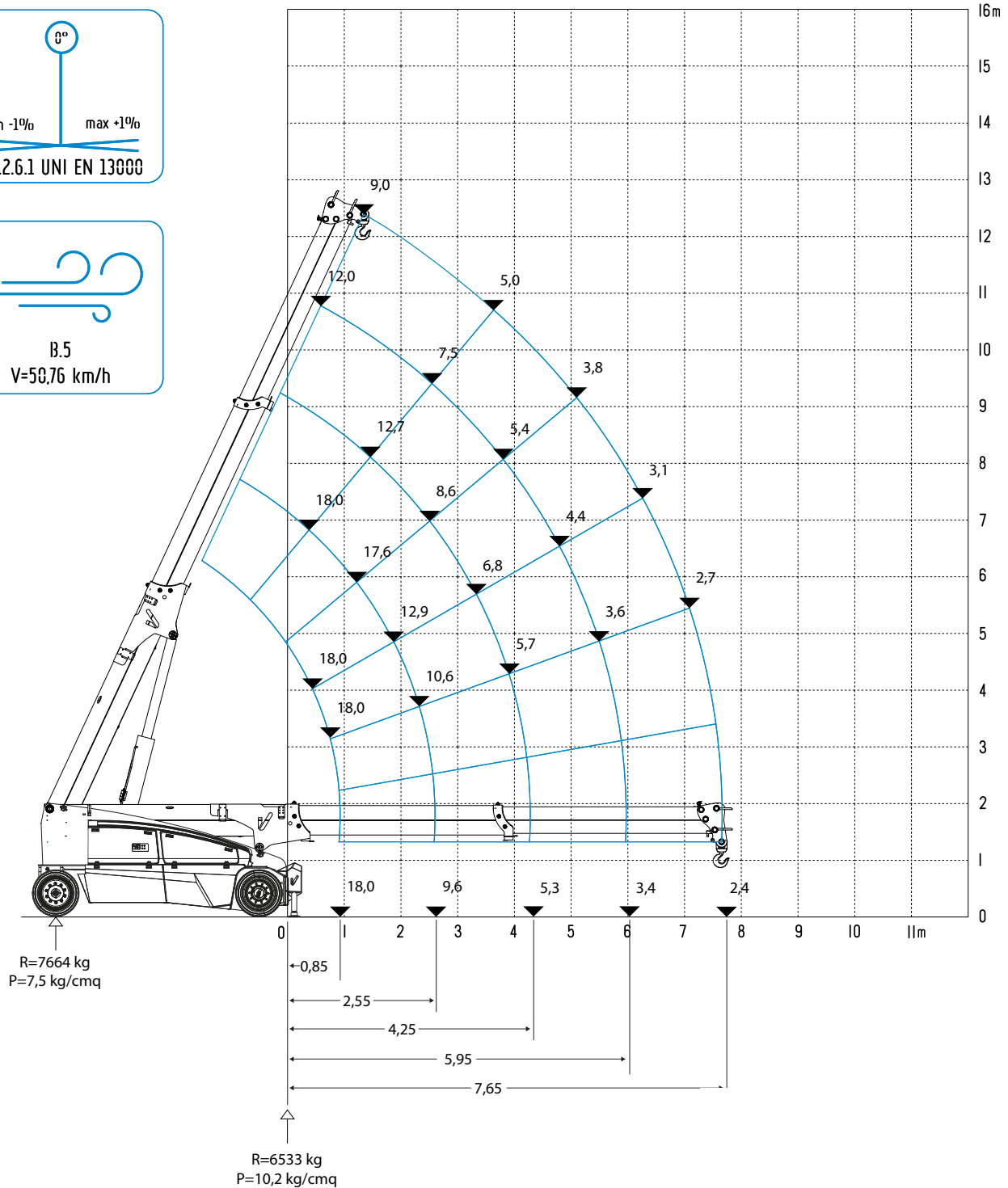
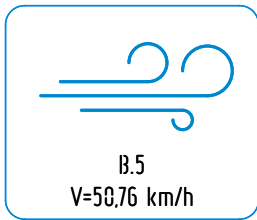
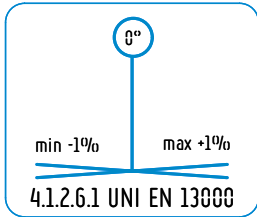

V180RC

LOAD DIAGRAM (t)

Diagramma di carico (t)

Tableau de charges utiles (t)

Traglastdiagramm (t) / Lastendiagramm (t)

Diagrama de las capacidades de carga (t)



COD.188.413.REVA

UNI EN 13000:2014

ISO 4305:2014

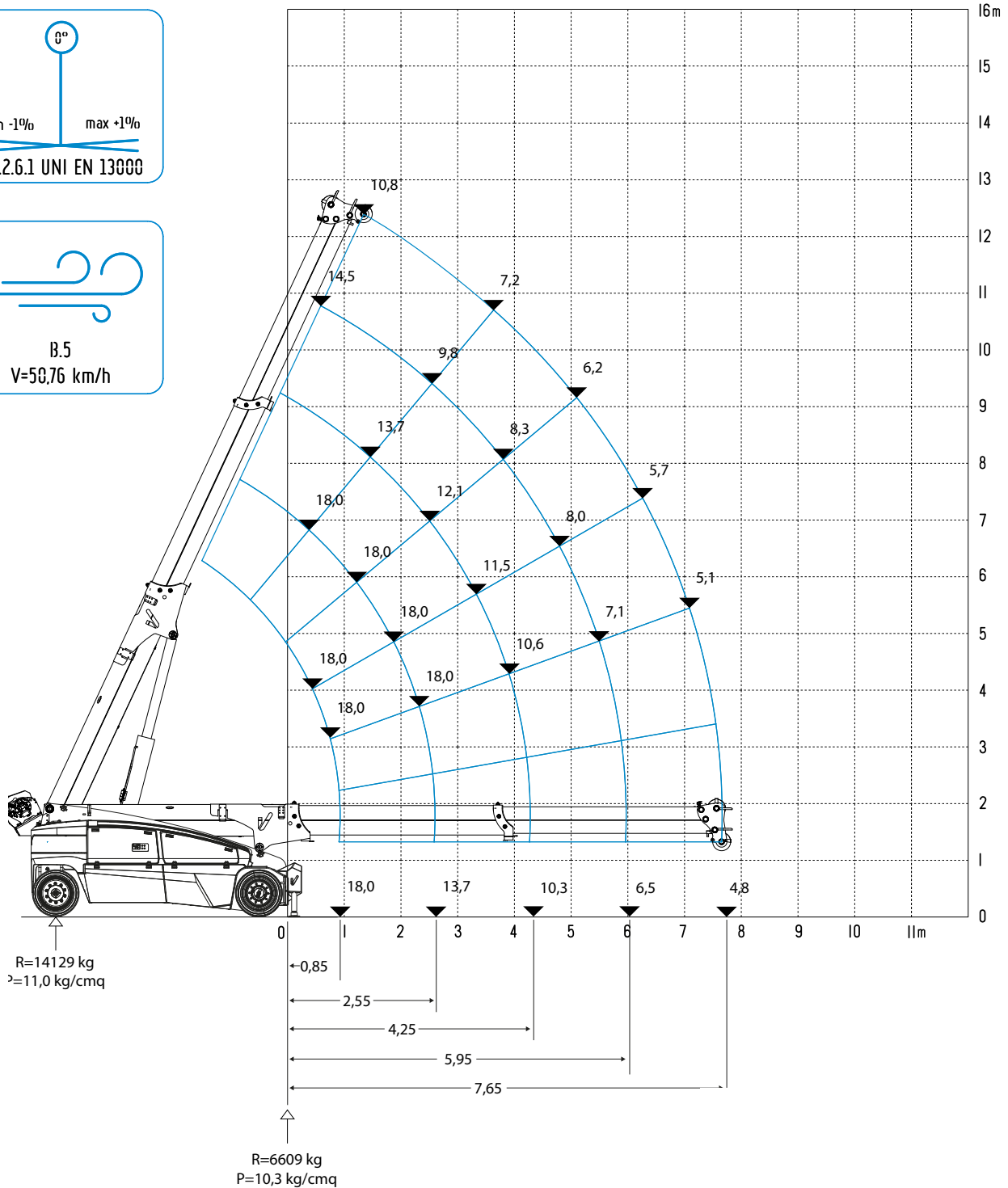
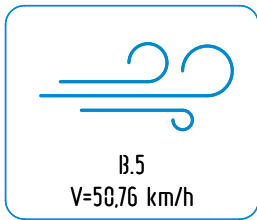
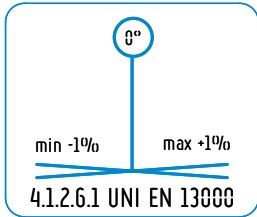

V180RC

LOAD DIAGRAM (t)

Diagramma di carico (t)

Tableau de charges utiles (t)

Traglastdiagramm (t) / Lastendiagramm (t)

Diagrama de las capacidades de carga (t)



POS. 1
COD.188.417.REV.A

UNI EN 13000:2014
ISO 4305:2014

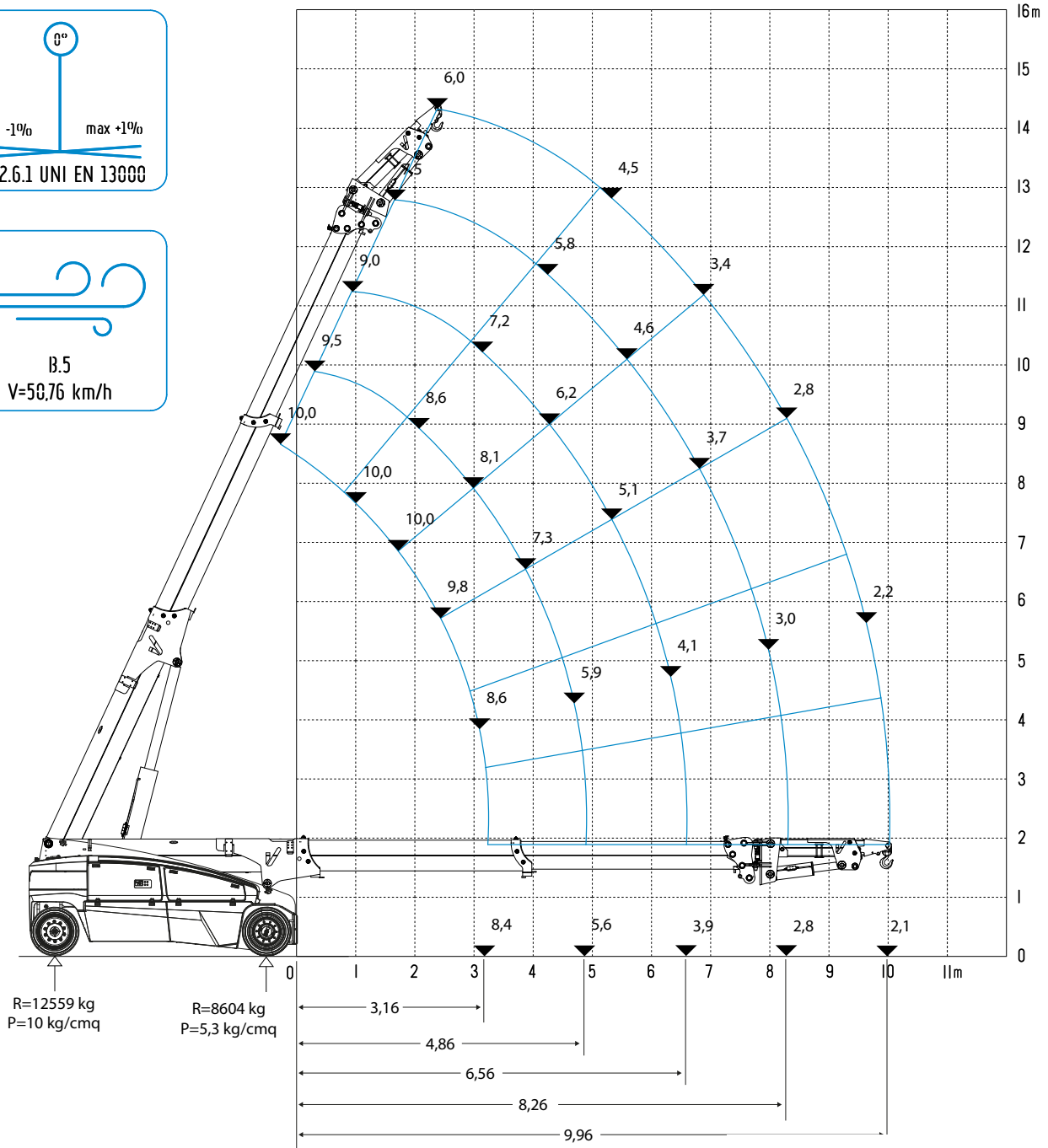
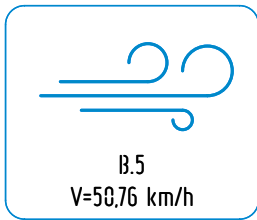
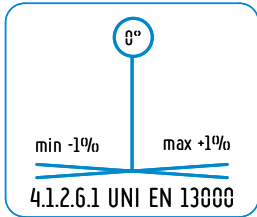

V180RC

LOAD DIAGRAM (t)

Diagramma di carico (t)

Tableau de charges utiles (t)

Traglastdiagramm (t) / Lastendiagramm (t)

Diagrama de las capacidades de carga (t)



POS. 2
COD.188.417.REV.A

UNI EN 13000:2014
ISO 4305:2014

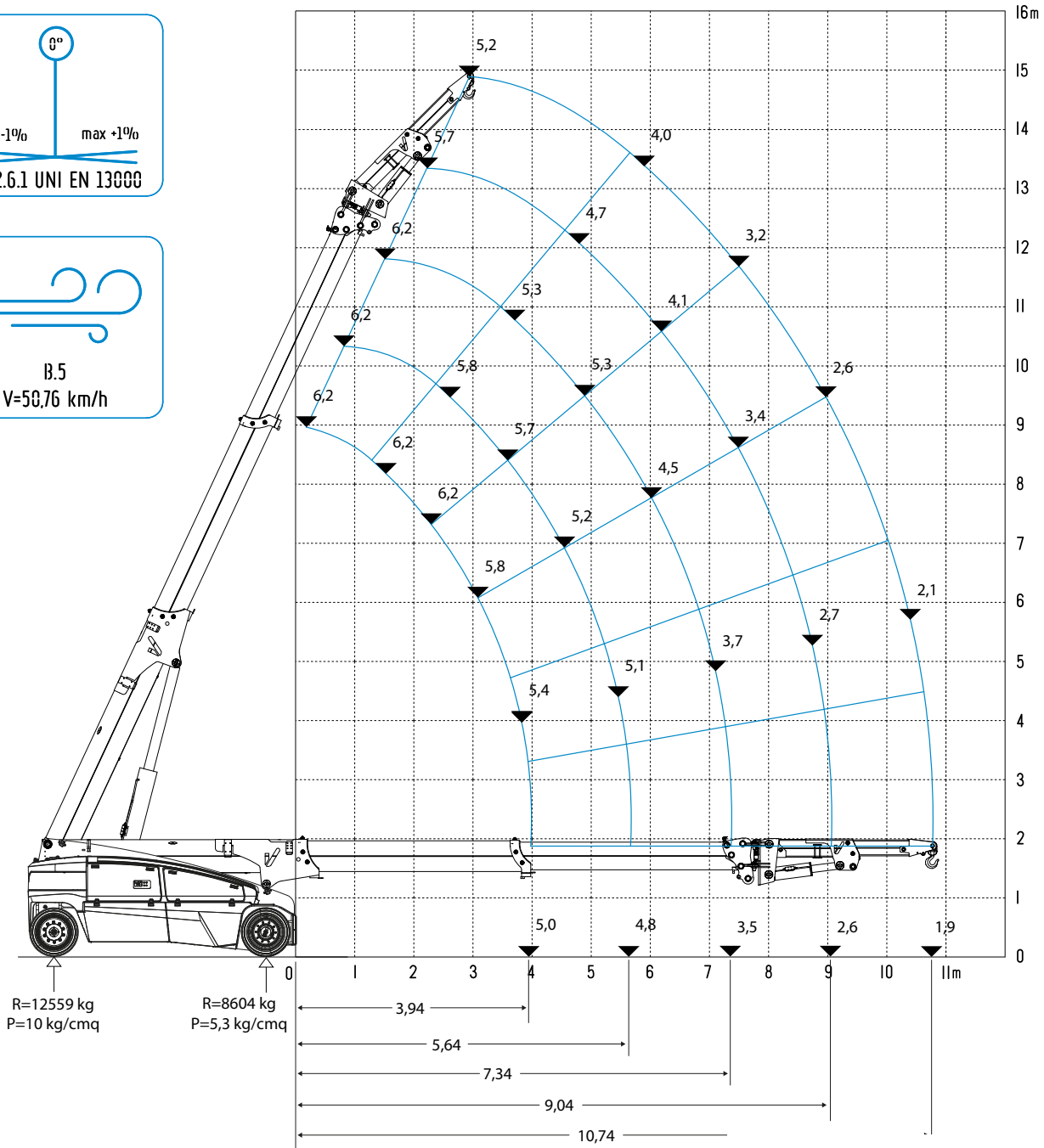
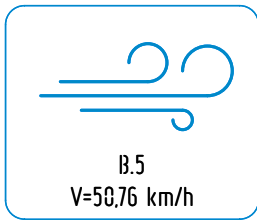
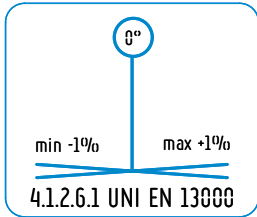

V180RC

LOAD DIAGRAM (t)

Diagramma di carico (t)

Tableau de charges utiles (t)

Traglastdiagramm (t) / Lastendiagramm (t)

Diagrama de las capacidades de carga (t)



POS. 3
COD.188.417.REV.A

UNI EN 13000:2014
ISO 4305:2014

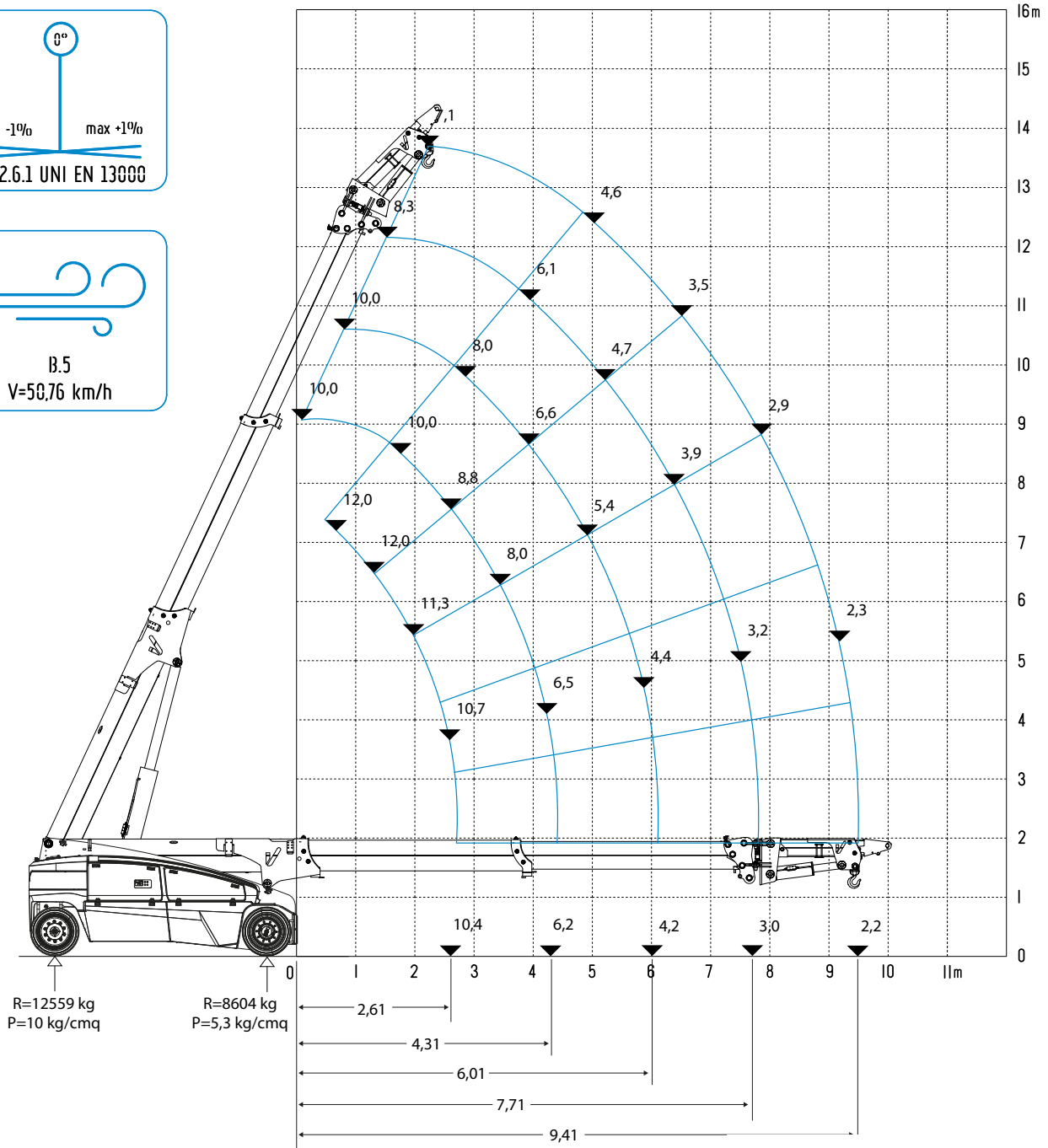
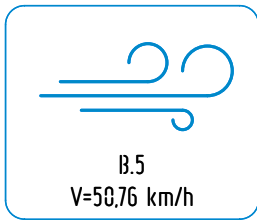
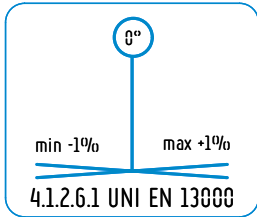

V180RC

LOAD DIAGRAM (t)

Diagramma di carico (t)

Tableau de charges utiles (t)

Traglastdiagramm (t) / Lastendiagramm (t)

Diagrama de las capacidades de carga (t)



POS. 2
COD.188.417.REV.A

UNI EN 13000:2014
ISO 4305:2014

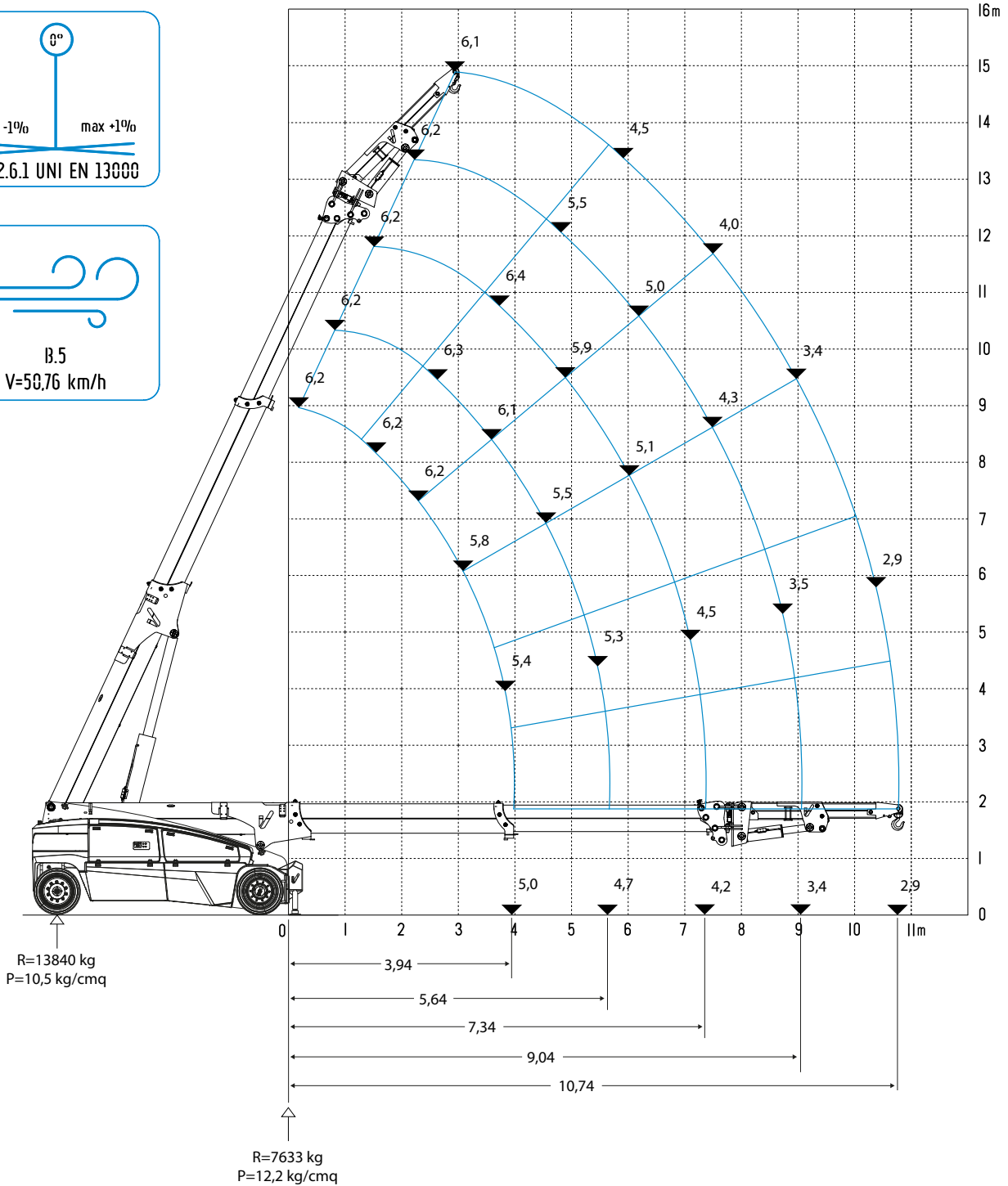
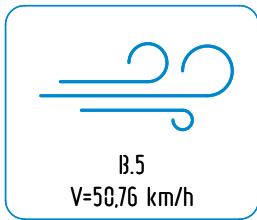
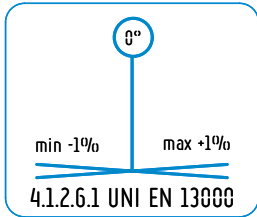

V180RC

LOAD DIAGRAM (t)

Diagramma di carico (t)

Tableau de charges utiles (t)

Traglastdiagramm (t) / Lastendiagramm (t)

Diagrama de las capacidades de carga (t)



POS. 3
COD.188.417.REV.A

UNI EN 13000:2014
ISO 4305:2014

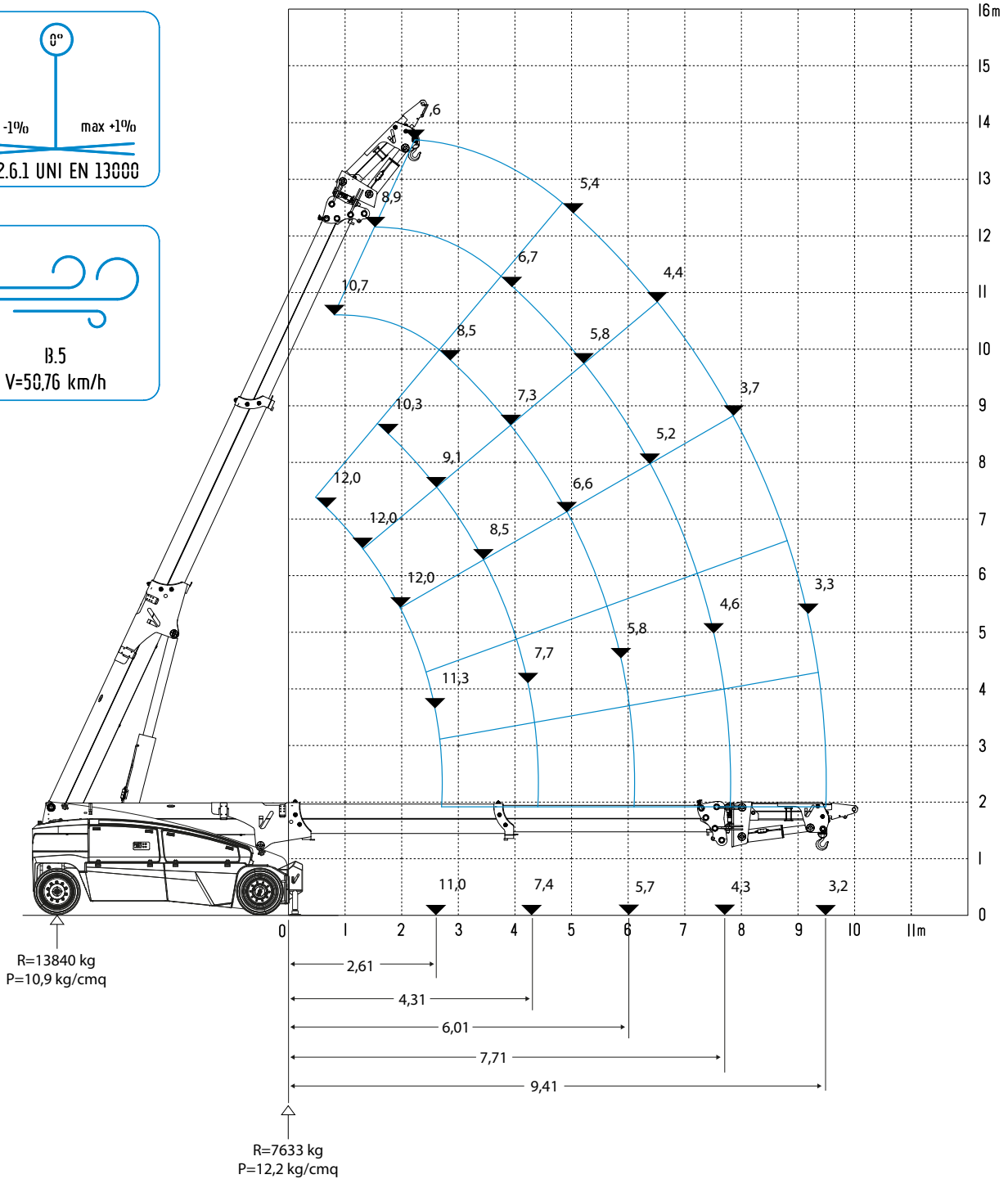
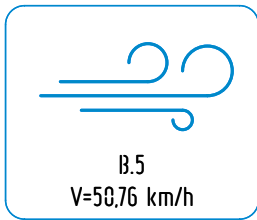
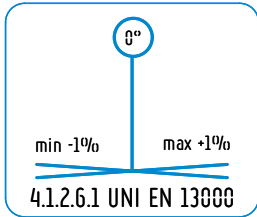

V180RC

LOAD DIAGRAM (t)

Diagramma di carico (t)

Tableau de charges utiles (t)

Traglastdiagramm (t) / Lastendiagramm (t)

Diagrama de las capacidades de carga (t)



COD.188.418.REVA

UNI EN 13000:2014

ISO 4305:2014

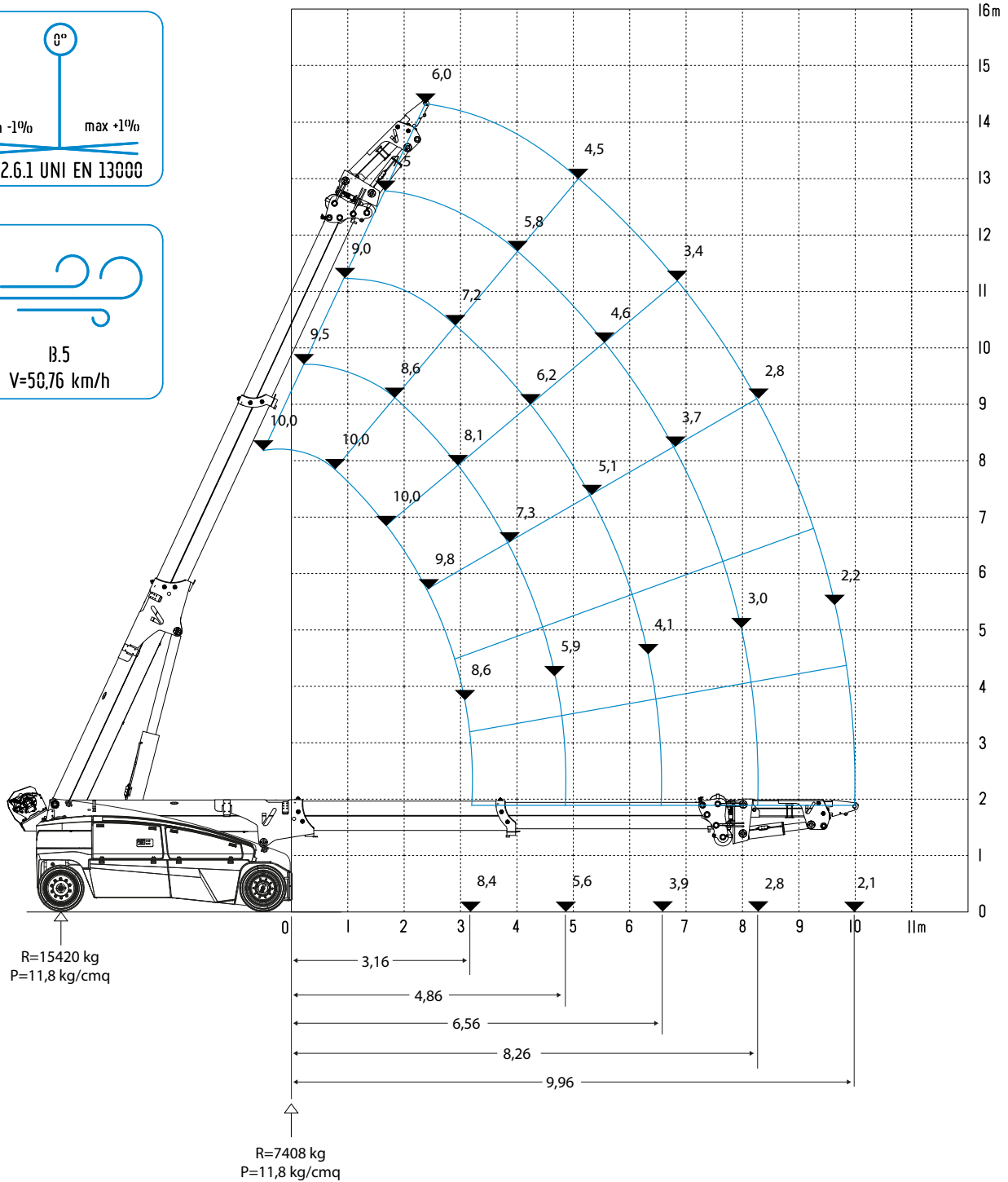
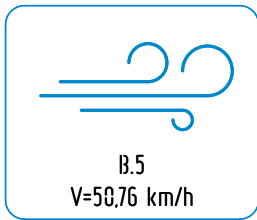
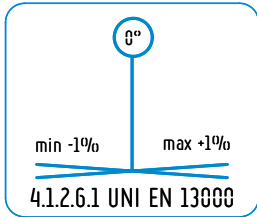

V180RC

LOAD DIAGRAM (t)

Diagramma di carico (t)

Tableau de charges utiles (t)

Traglastdiagramm (t) / Lastendiagramm (t)

Diagrama de las capacidades de carga (t)



COD.188.418.REVA

UNI EN 13000:2014

ISO 4305:2014

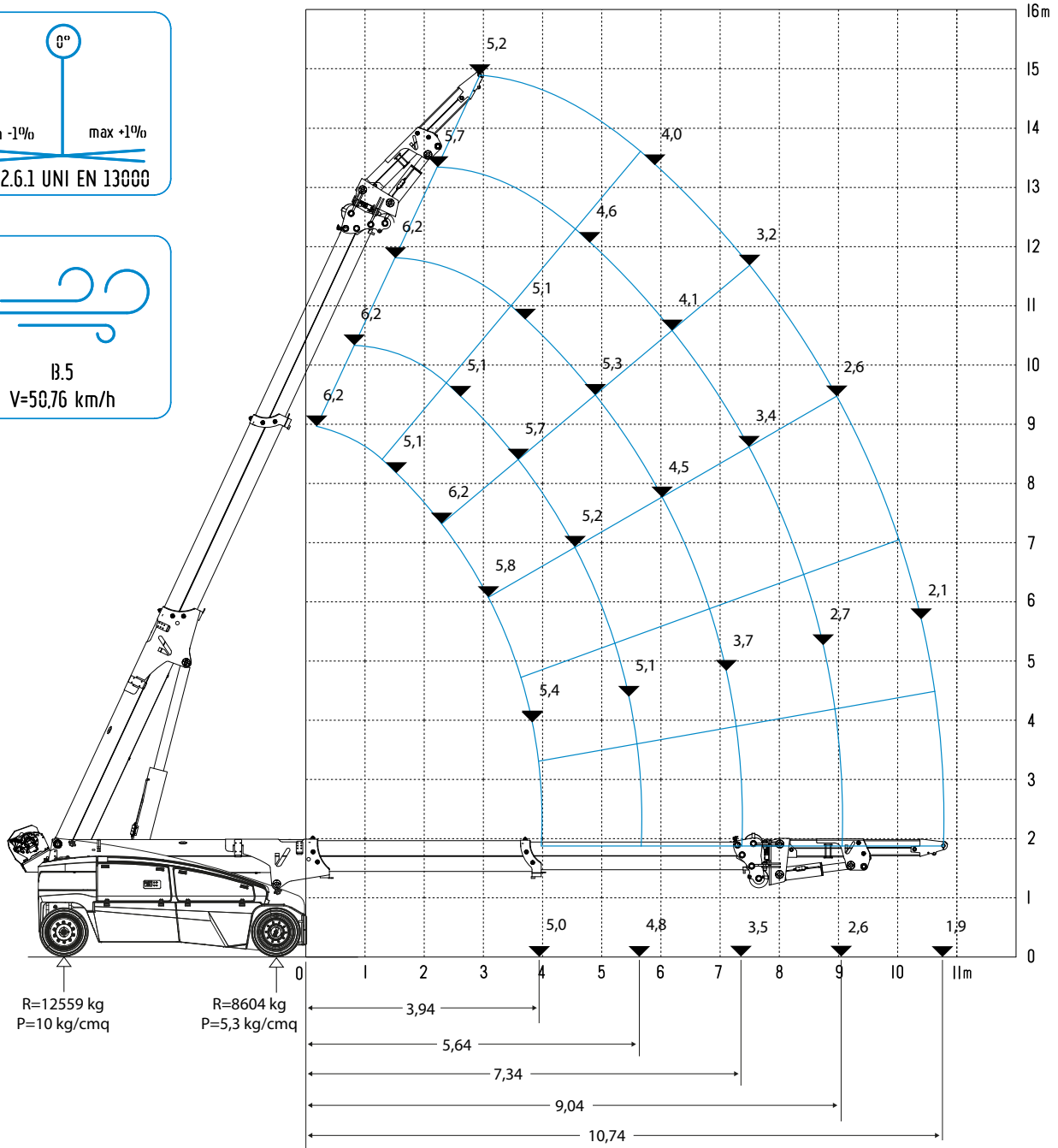
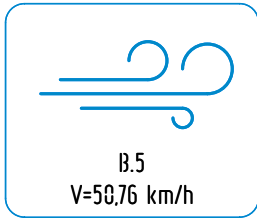
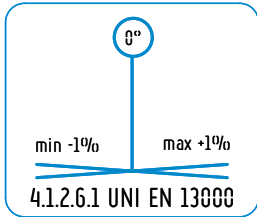

V180RC

LOAD DIAGRAM (t)

Diagramma di carico (t)

Tableau de charges utiles (t)

Traglastdiagramm (t) / Lastendiagramm (t)

Diagrama de las capacidades de carga (t)



COD.188.418.REVA

UNI EN 13000:2014

ISO 4305:2014

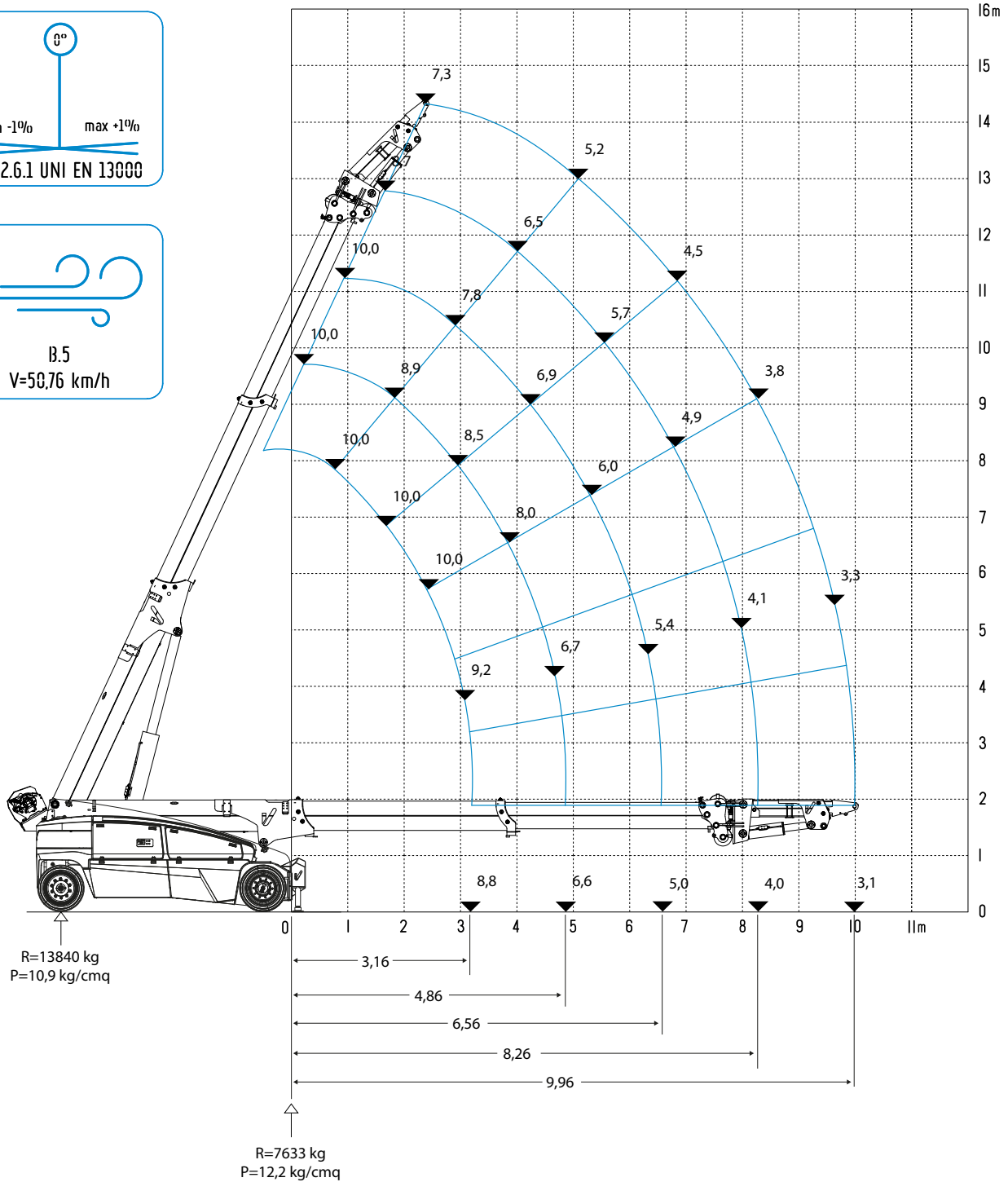
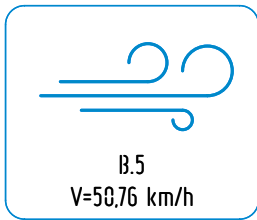
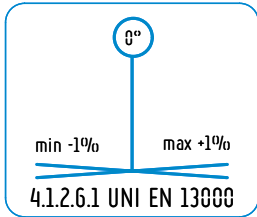

V180RC

LOAD DIAGRAM (t)

Diagramma di carico (t)

Tableau de charges utiles (t)

Traglastdiagramm (t) / Lastendiagramm (t)

Diagrama de las capacidades de carga (t)



COD.188.418.REVA

UNI EN 13000:2014

ISO 4305:2014

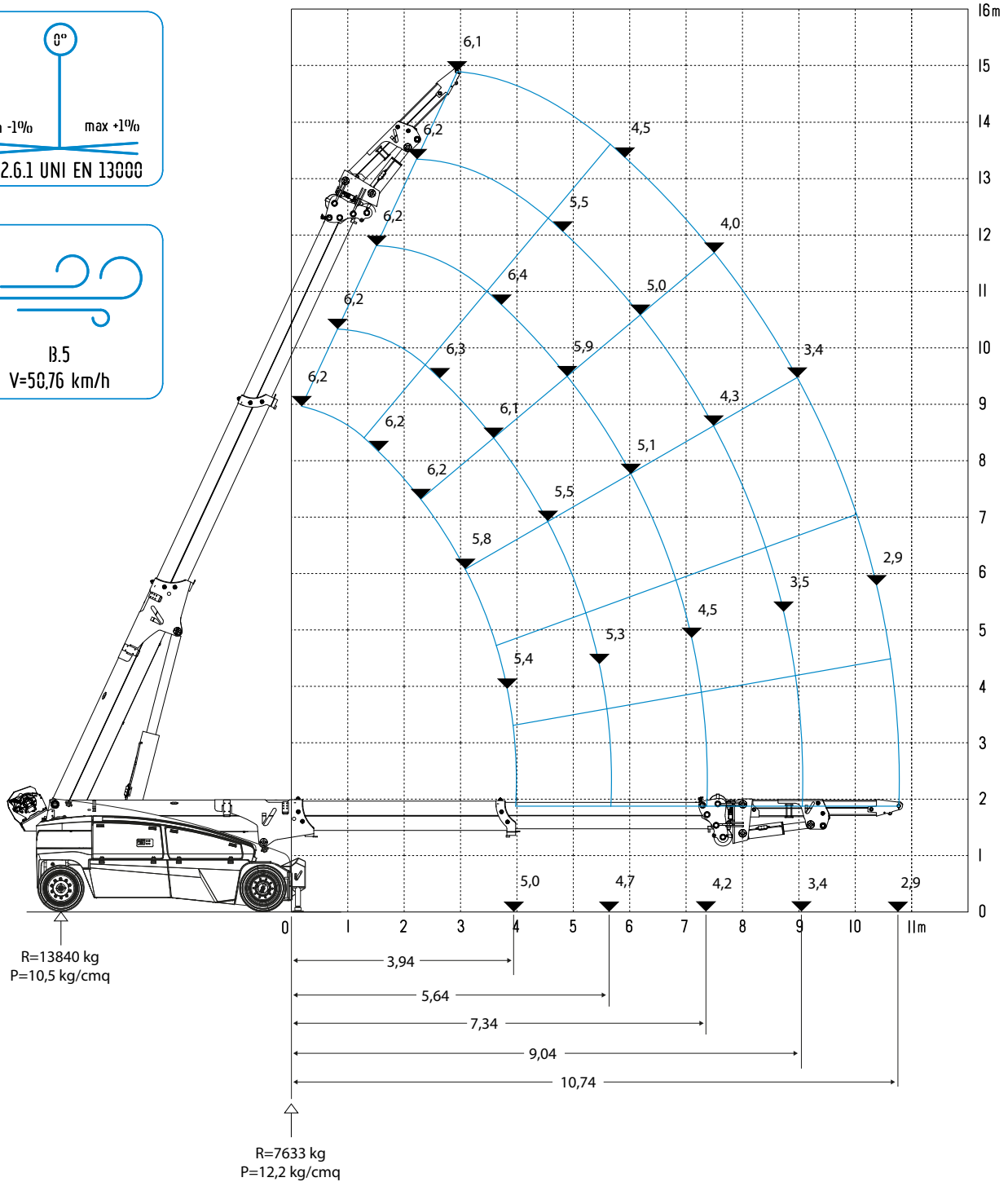
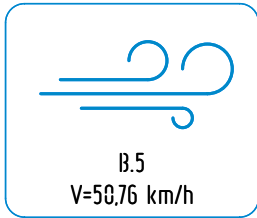
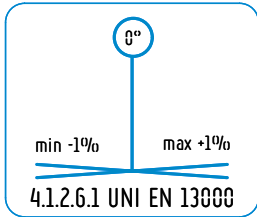

info.valla@tadano.com

www.tadano.com

Tadano Ltd.

Kanda Square 18th Floor, 2-2-1 Kanda-Nishikicho, Chiyoda-ku, Tokyo 101-0054, Japan

Phone: +81-3-6811-7309 (International Division)

Manitex Valla S.R.L.

Via Leonardo da Vinci, 12 29016 - Careco - Piacenza - Italia.

Tel.: +39 0523 256411

