



# OCTOPLUS 17



# Octoplus 17

## Tracked aerial work platforms

### WORKING AREA

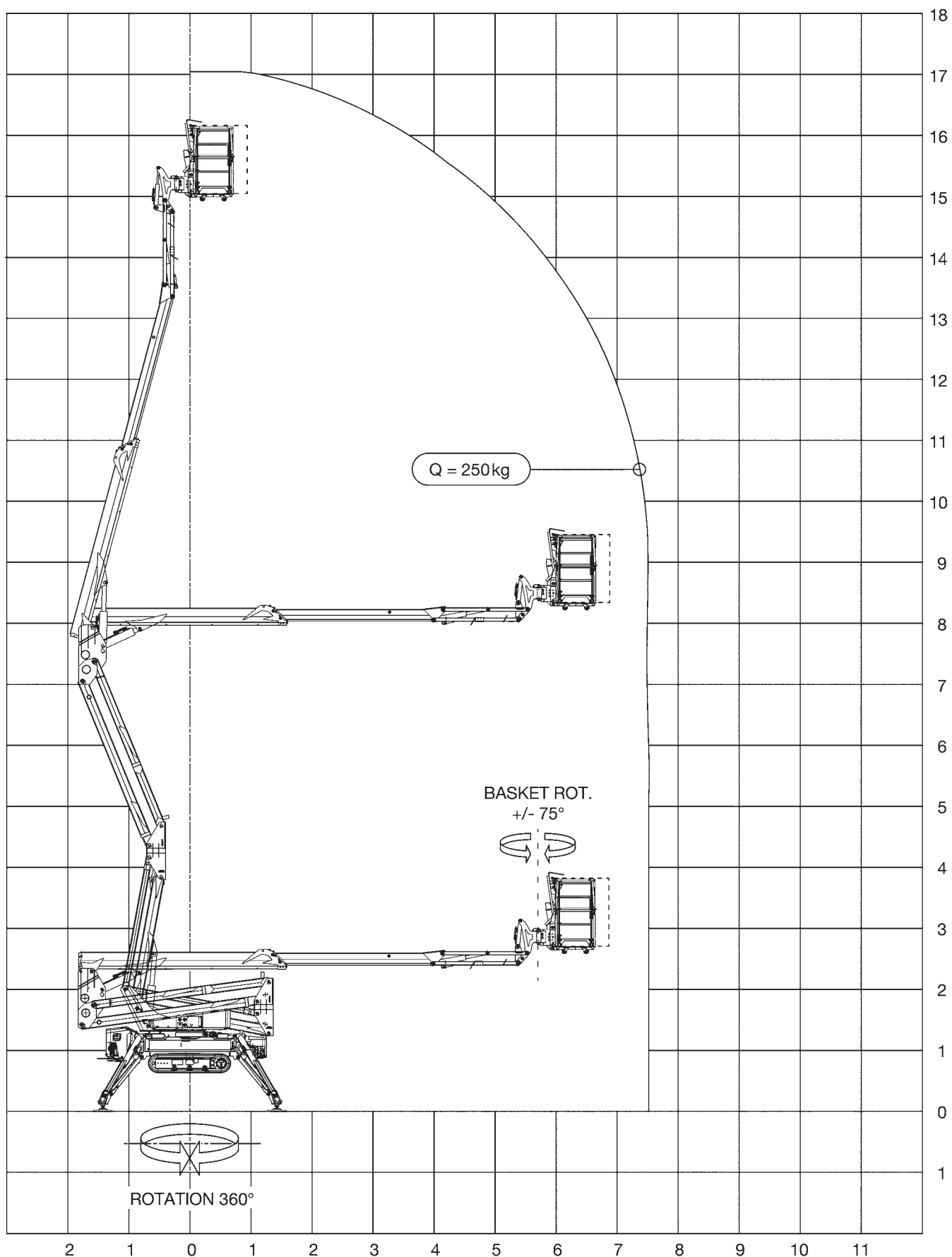

# TECHNICAL DRAWINGS

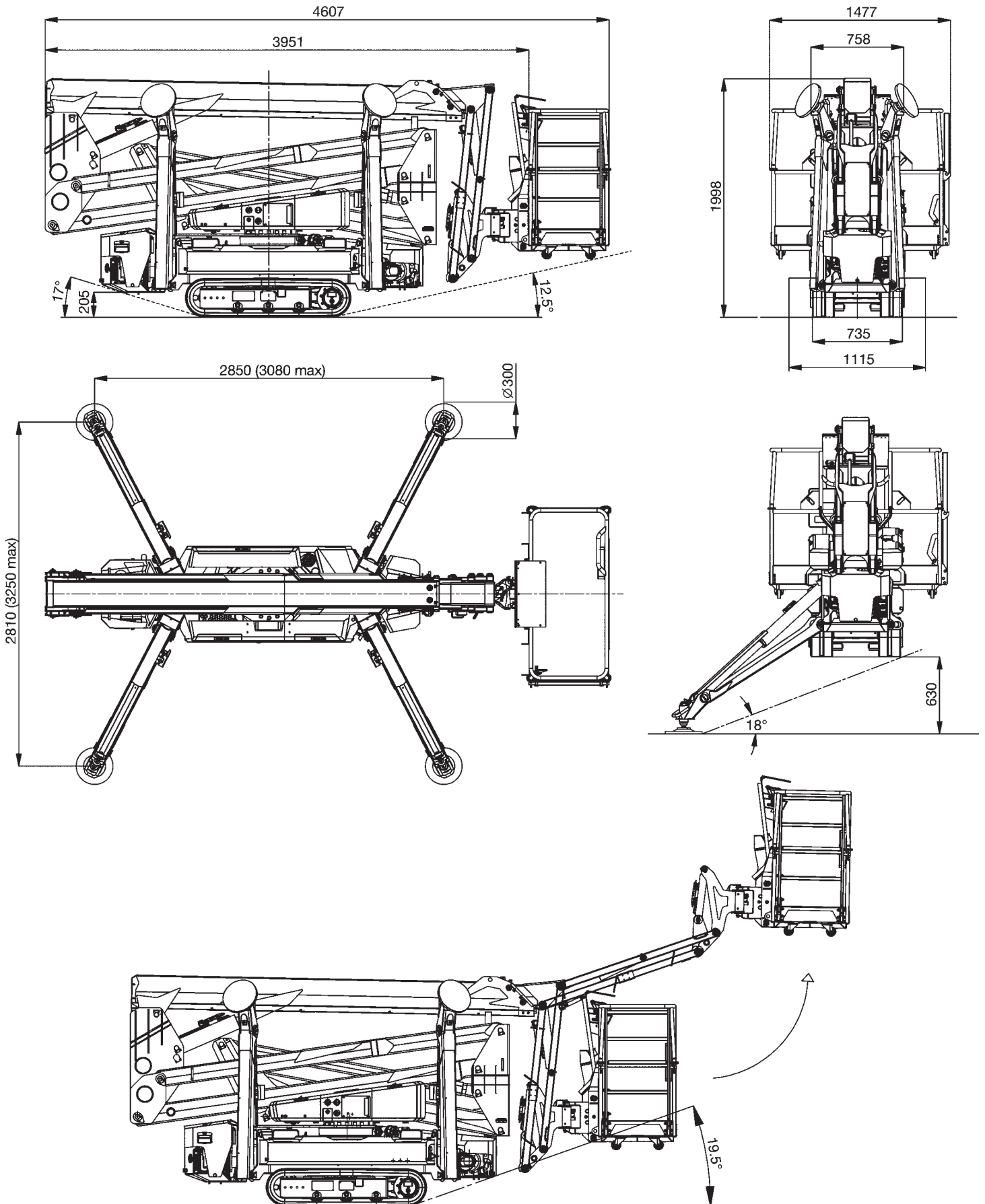

## SPECIFICATIONS

Max working height	17 m	Basket height	1.1 m
Maximum basket floor height	15 m	Basket length	1.4 m
Max outreach	7.6 m	Basket width	0.7 m
Up and over clearance – scissor	7.6 m	Machine length (stowed)	4.6 m
Max capacity	250 kg	Machine length without basket (stowed)	3.9 m
Basket controls	Radio remote control	Machine height (stowed)	1.98 m
Outrigger and tracked undercarriage controls	Radio remote control	Minimum overall width (stowed)	0.758 m
Basket (materials and dimensions)	Aluminium basket 1400 x 1100 x 700 mm max occupancy: 2 persons	Maximum ground clearance	0.2 m
Jib - working angle	116°	Track size	1.35 x 0.18 m
Jib – rotation angle	NA	Outrigger footprint (fully extended)	2.85 x 2.81 m
Basket – rotation angle	+/- 75°	Outrigger footprint (partially extended)	NA
Turret – rotation angle	+/- 180°	Outrigger footprint (retracted)	NA
Outrigger setup possible on slopes up to	18°	Outrigger plates – dimensions	Ø 0.3 m
Chassis height with outriggers deployed	0.63 m	Min weight	2330 kg
Track width (retracted – extended)	0.735 – 1.115 m	Max track ground pressure	0.95 daN/cm <sup>2</sup>
Gradeability – traveling	35% rear (30% with battery pack) – 27% front	Max outrigger ground pressure	3.98 daN/cm <sup>2</sup>
Max travel speed	2.5 km/h (1.6 km/h with battery pack)	Maximum reaction force on outriggers	1251 daN
Working envelope – Variable outrigger setup	NA	Combustion engine (STD)	Petrol Honda iGX390 11.7 HP
Homing / Memory function	Optional	Fuel tank	6 L
Automatic stabilization	✓	Electric motor (STD)	Single-phase 2.2 kW 230 V AC
Loading/unloading function	✓	Combustion engine (OPT)	Diesel Hatz 1B50E 10 HP
Electric emergency lowering	✓	Battery pack (OPT)*	7.4 kWh – 73.6 V – 4 kW engine

\* Excludes internal combustion engine power supply

## EQUIPMENT

3 travel speeds
4" turret display
40 L hydraulic oil tank
220 V AC power socket in the basket with RCBO
Ø 300 mm outrigger plate
AGM 95 Ah battery
Aluminium basket, 1.4 m, with access ladder
Automatic stabilization and chassis tilt sensor
Basket hydraulic rotation 75° right – 75° left with rotary actuator
Black tracks
Corrosion protection for structural components and stainless steel fasteners
Dual USB charging ports in the basket
Electro-hydraulic controls
Electronic engine RPM control
Engine start via radio remote control or turret display
Emergency push-button panel for basket control functions located on the turret
Emergency stop button bypass
Emergency stop button with engine shutdown on turret and in radio remote control
Extendable tracks
Hoses and cables routed inside the boom
Hour meter
Load cell bypass
Load-holding valves on all cylinders
Loading/unloading for trailer and truck bed loading
Load limiting system
Pressure relief valve in hydraulic circuit
Quick-release protection covers for chassis
Radio remote control with display and charger on the turret
Removable basket with transport wheels
Single-phase electric motor 220 V AC / 50 Hz / 2.2 kW
Start button on turret
Thermal protection for the electrical system
Tracks with variable displacement motors and braking system
Valves for emergency lowering and manual pump
White and blue standard paint (RAL 9016 white – RAL 5002 blue)

## OPTIONAL

7" display protection
7" turret display
7.4 kWh battery pack – 73.6 V – 72 V 4 kW motor – fully charged in 5.5 h
12 V DC emergency electric pump, 1.6 kW
12 V DC floodlight in the basket
Ø 200 mm outrigger plate
Aluminium basket 0.8 m
Aluminium basket 1.8 m
Anti-collision system between extendable structure and chassis
Cable for radio remote control in the basket
Customer-specific decals
Deadman foot pedal in the basket
Debris protection kit for telescopic boom
Dual air and water line
Extended warranty
Hatz 1B50E diesel engine, 10 HP CAN, with 5 L fuel tank
Homing function and memory function
Load distribution plates with retaining sleeve
Logo customization on 7" display and radio remote control
Non-standard paint finish
Outrigger deployment and travelling from the basket
Protective cover for aluminium basket controls
Remote connectivity kit (5 year subscription)
Safety harness kit, 2 pieces
Side storage box
Single-phase electric motor 100 V AC / 50-60 Hz / 1.1 kW
Single-phase electric motor 110 V AC / 50 Hz / 1.1 kW
Single-phase electric motor 110 V AC / 60 Hz / 1.1 kW
Turret rotation increased to +/-210° (420° non-continuous)
White non-marking tracks

[www.tadano.com](http://www.tadano.com)

**Tadano Ltd.**

Kanda Square 18th Floor, 2-2-1 Kanda-Nishikicho, Chiyoda-ku, Tokyo 101-0054, Japan  
Phone: +81-3-6811-7309 (international Division)

**PM OIL & STEEL S.P.A.**

Via G. Verdi, 22 - 41018 - San Cesario sul Panaro (Modena) - Italy

