



V210R

Technical Data | Metric



21 t

MAX PAYLOAD

Portata massima / Capacité max

Max Tragfähigkeit / Max capacidad

V210R

TECHNICAL INFORMATION AND OVERALL SIZE

Informazioni tecniche e dimensioni d'ingombro
Informations techniques et dimensions globales
Technische Informationen und Gesamtgröße
Información técnica y dimensiones totales

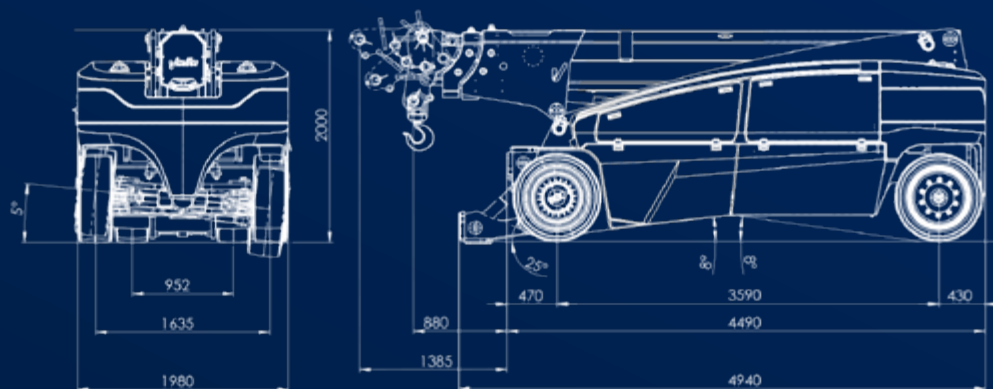

MAX PAYLOAD

Portata massima / Capacité max **21.000 kg**
Max Tragfähigkeit / Max capacidad

TOTAL WEIGHT

Peso totale / Poids total **23.270 kg**
Gesamtgewicht / Peso total

DIMENSIONS

Dimensioni / Dimensions **4490 x 2000 x 1980 mm**
Abmessungen / Dimensiones

FRONT

Anteriore / Avant / Vorderrad / Delantera **N° 4 / 355/50 – 20"**

REAR

Posteriore / Arrière / Hinterrad / Trasera **N° 2 / 355/50 – 20"**

HYDRAULICS

Impianto idraulico (Pressione massima/Potenza motore) **220 Bar – 33 kW AC**
Hydraulique (Pression maxi/Puissance moteur)
Hydraulik (Max Druck/Motorleistung)
Hidraulica (Presion max/Potencia motor)

FRONT-WHEEL DRIVE

Trazione anteriore / Traction avant **2 x 7.5 kW AC**
Frontantrieb / Tracción delantera

REAR STEERING

Sterzata posteriore / Direction arrière **+/-90°**
Hintere Lenkung / Dirección trasera

BATTERY

Batteria / Batterie / Batterie / Batterie **96V - 1.050 Ah**

REMOVABLE COUNTERWEIGHTS

Contrappesi removibili / Contrepoids amovibles **N° 3 x 2.220 kg**
Abnehmbare Gegengewichte / Contrapesos removibles

FRONT ELECTRO-HYDRAULIC BRAKES

Freni elettroidraulici anteriori / Freins électrohydrauliques avant
Elektrohydraulische Vorderradbremmen / frenos electrohidráulicos delanteros

V210R

MAXIMUM PERFORMANCE AND EQUIPMENTS

Massime prestazioni ed equipaggiamenti
Performances maximales et équipements
Maximale Leistung und Ausrüstung
Máximas prestaciones y equipamiento

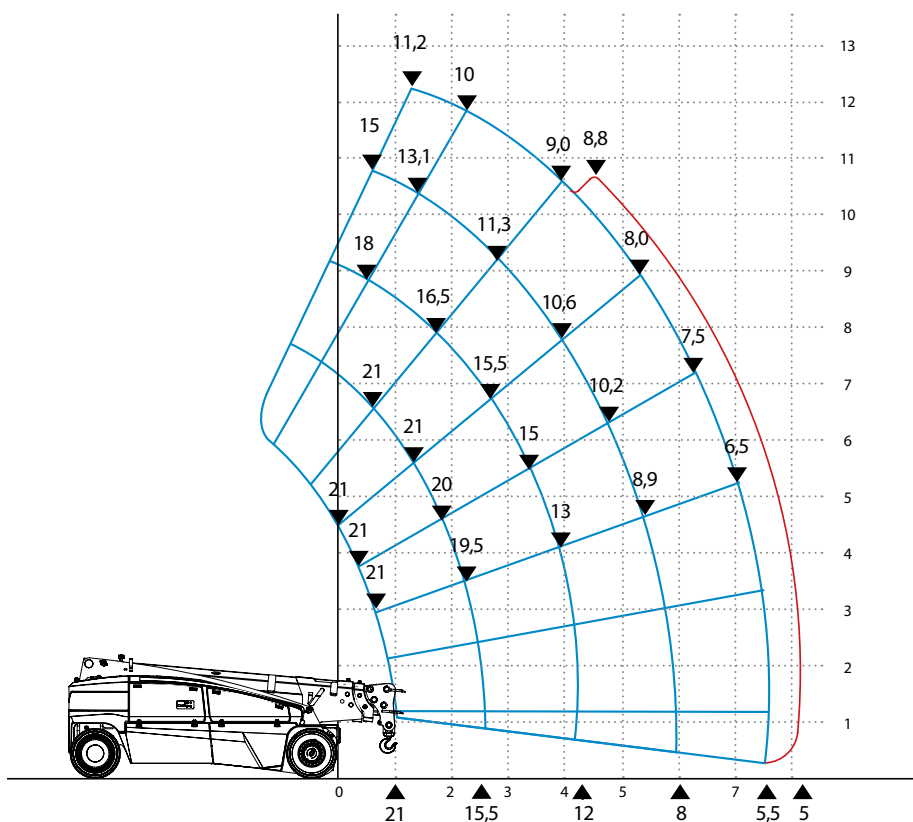

REFERENCE STANDARDS

Normative di riferimento / Normes de référence
Referenzstandards / Estandards de referencia

2006/42 CE
EN 13000

STANDARD

NON-MARKING TIRES

Ruote anti traccia / Roues anti-traces
Nicht-markierende Räder / Ruedas anti-marcas

VARIABLE TILT HEAD

Testa ad inclinazione variabile / Tête à inclinaison variable
Abwinkelbare Spitze / Cabezal ajustable

RADIO-CONTROL

Radiocomando / Radiocommande / Fernsteuerung / Radio control

HOOK

Gancio / Crochet / Haken / Gancho

STABILIZER CROSSBAR

Barra stabilizzatrice anteriore / Barre stabilisatrice
Vorderradabstützung / Barra estabilizadora

OPTIONAL

WINCH

Argano / Treuil / Winde / Cabrestante

FIXED MECHANICAL JIB

Jib meccanico non ripiegabile / Fléchette mécanique non repliable
Feste mechanische Spitze / Pluma mecanica no plegable

FOLDABLE HYDRAULIC JIB

Jib idraulico ripiegabile / Fléchette hydraulique repliable
Klappbarer hydraulischer Ausleger / Pluma hidráulica plegable

FOLDABLE TELESCOPIC HYDRAULIC JIB

Jib idraulico telescopico ripiegabile / Fléchette hydraulique télescopique repliable
Faltbarer teleskopischer hydraulischer jib/ Pluma hidráulica telescópica plegable

SELF-LEVELLING FORKS

Forche autolivellanti / Fourches à nivellement automatique
Selbstnivellierende Gabeln / Horquillas autonivelantes

LITHIUM BATTERIES

Batterie al litio / Batteries au lithium
Lithiumbatterien / Baterías de litio

ATEX TRANSFORMATION

Trasformazione ATEX / Transformation ATEX
ATEX-Umwandlung / Transformación ATEX

VALLA CONNECT SYSTEM

info.valla@tadano.com

www.tadano.com

Tadano Ltd.

Kanda Square 18th Floor, 2-2-1 Kanda-Nishikicho, Chiyoda-ku, Tokyo 101-0054, Japan

Phone: +81-3-6811-7309 (International Division)

Manitex Valla S.R.L.

Via Leonardo da Vinci, 12 29016 - Careco - Piacenza - Italia.

Tel.: +39 0523 256411



Reaching new heights

