



V90R

Technical Data | Imperial



17.635 lb

MAX PAYLOAD

Portata massima / Capacité max
Max Tragfähigkeit / Max capacidad

V90R

TECHNICAL INFORMATION AND OVERALL SIZE

Informazioni tecniche e dimensioni d'ingombro

Informations techniques et taille globale

Technische information und Gesamte Größe

Información técnica y dimensiones totales

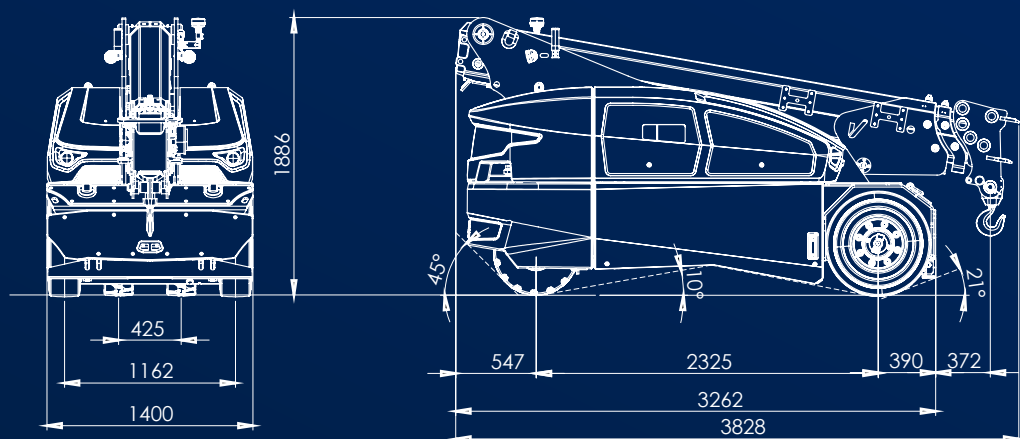

MAX PAYLOAD

Portata massima / Capacité maxi

17.635 lb

Max Tragfähigkeit / Max capacidad

TOTAL WEIGHT

Peso totale / Poids total

18.410 lb

Gesamtgewicht / Peso total

DIMENSIONS

Dimensioni / Dimensions

125 x 55 x 75 in

Abmessungen / Dimensiones

FRONT

Anteriore / Avant / Vorderrad / Delantera

N° 2 S.E. / 250 – 15”

REAR

Posteriore / Arrière / Hinterrad / Trasera

N° 2 S.E. / 23x9 – 10”

HYDRAULICS

Impianto idraulico (Pressione massima/Potenza motore)

Hydraulique (Pression maxi/Puissance moteur)

220 Bar – 12 kW AC

Hydraulik (Max Druck/Motorleistung)

Hidraulica (Presion max/Potencia motor)

FRONT-WHEEL DRIVE

Trazione anteriore / Traction avant

2 x 4.2 kW AC

Frontantrieb / Tracción delantera

REAR STEERING

Sterzata posteriore / Direction arrière

800W AC - 180°

Hintere Lenkung / Direccion trasera

BATTERY

Batteria / Batterie / Batterie / Batterie

80V - 560 Ah

COUNTERWEIGHTS

Contrappesi / Contrepoids

N° 2 x 2.865 lb

Gegengewichte / Contrapesos

ELECTRO BRAKES

Freni elettroidraulici / Freins electro / ElektroBremse / Frenos electros

V90R

MAXIMUM PERFORMANCE AND EQUIPMENTS

Massime prestazioni ed equipaggiamenti
Performances maximales et équipements
Maximale Leistung und Ausrüstung
Máximas prestaciones y equipamiento

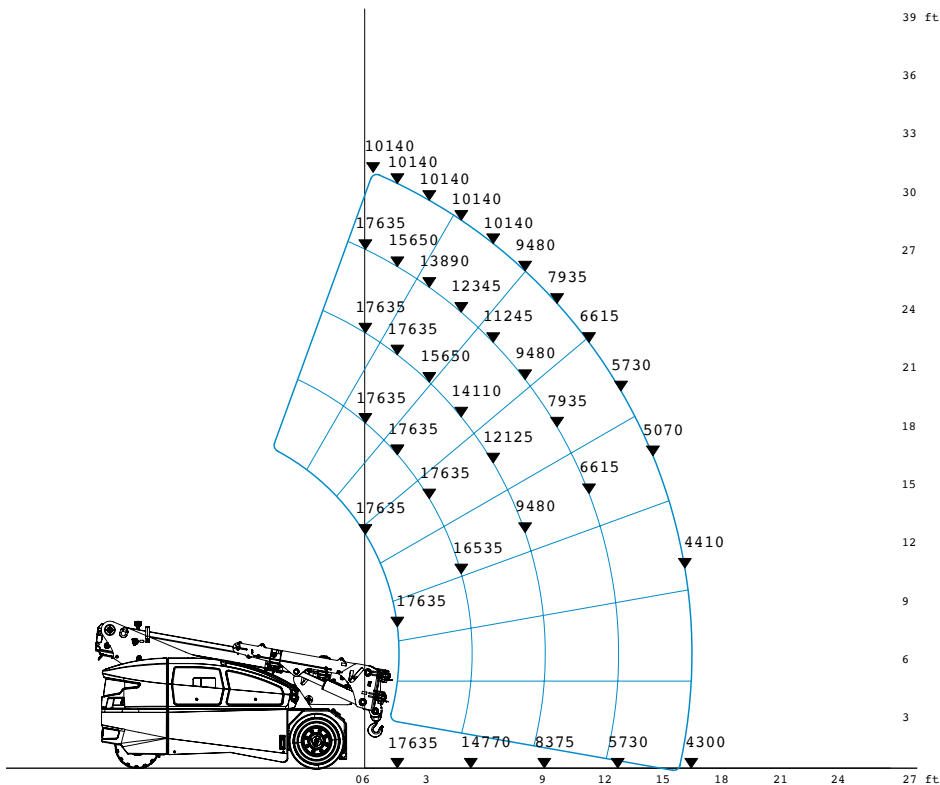

REFERENCE STANDARDS

Normative di riferimento / Normes de référence
Referenzstandards / Estandards de referencia

2006/42 CE
EN 13000

STANDARD

NON-MARKING TIRES

Ruote anti traccia / Roues anti-traces
Nicht-markierende Räder / Ruedas anti-marcas

VARIABLE TILT HEAD

Testa ad inclinazione variabile / Tête à inclinaison variable
Abwinkelbare Spitze / Cabezal ajustable

RADIO-CONTROL

Radiocomando / Radiocommande / Fernsteuerung / Radio control

HOOK

Gancio / Crochet / Haken / Gancho

OPTIONAL

STABILIZER CROSSBAR

Barra stabilizzatrice anteriore / Barre stabilisatrice
Vorderradabstützung / Barra estabilizadora

WINCH

Argano / Treuil / Winde / Cabrestante

FOLDABLE MECHANICAL JIB

Jib meccanico ripiegabile / Fléchette mécanique repliable
Klappbarer mechanischer Ausleger / Pluma mecanica plegable

FOLDABLE HYDRAULIC JIB

Jib idraulico ripiegabile / Fléchette hydraulique repliable
Klappbarer hydraulischer Ausleger / Pluma hidráulica plegable

SELF-LEVELLING FORKS

Forche autolivellanti / Fourches à nivellement automatique
Selbstnivellierende Gabeln / Horquillas autonivelantes

LITHIUM BATTERIES

Batterie al litio / Batteries au lithium
Lithiumbatterien / Baterías de litio

ATEX TRANSFORMATION

Trasformazione ATEX / Transformation ATEX
ATEX-Umwandlung / Transformación ATEX

VALLA CONNECT SYSTEM

info.valla@tadano.com

www.tadano.com

Tadano Ltd.

Kanda Square 18th Floor, 2-2-1 Kanda-Nishikicho, Chiyoda-ku, Tokyo 101-0054, Japan

Phone: +81-3-6811-7309 (International Division)

Manitex Valla S.R.L.

Via Leonardo da Vinci, 12 29016 - Careco - Piacenza - Italia.

Tel.: +39 0523 256411



Reaching new heights

