



25E

Technical Data | Metric



2.5t

MAX PAYLOAD

Portata massima / Capacité max

Max Tragfähigkeit / Max capacidad

25E

TECHNICAL INFORMATION AND OVERALL SIZE

Informazioni tecniche e dimensioni d'ingombro
Informations techniques et dimensions globales
Technische Informationen und Gesamtgröße
Información técnica y dimensiones totales

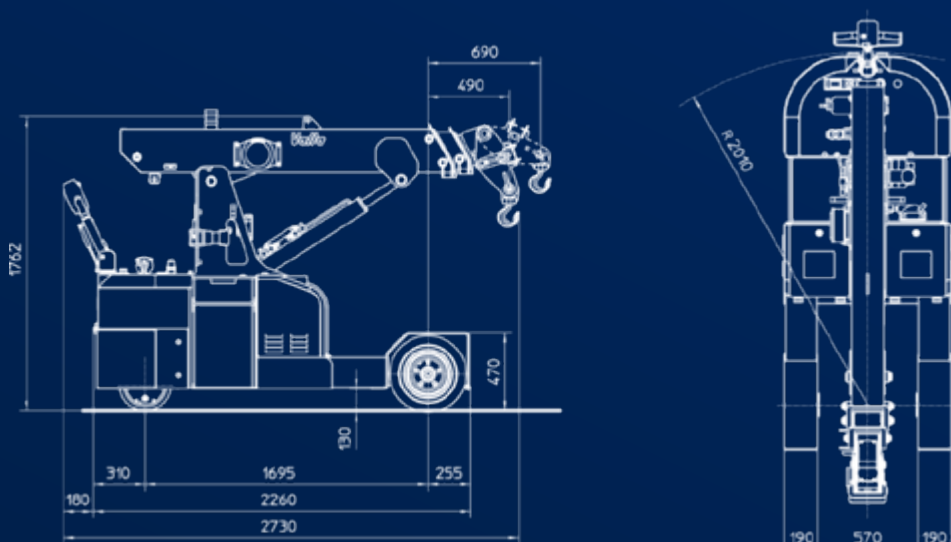

MAX PAYLOAD

Portata massima / Capacité max
Max Tragfähigkeit / Max capacidad

2.500 kg

TOTAL WEIGHT

Peso totale / Poids total
Gesamtgewicht / Peso total

2.400 kg

DIMENSIONS

Dimensioni / Dimensions
Abmessungen / Dimensiones

2260 x 950 x 1685 mm

FRONT

Anteriore / Avant / Vorderrad / Delantera

N° 2 18 x 7 - 8"

REAR

Posteriore / Arrière / Hinterrad / Trasera

N° 1 300 x 135

HYDRAULICS

Impianto idraulico (Pressione massima/Potenza motore)
Hydraulique (Pression maxi/Puissance moteur)
Hydraulik (Max Druck/Motorleistung)
Hidraulica (Presion max/Potencia motor)

220 Bar – 4 kW AC

FRONT-WHEEL DRIVE

Trazione anteriore / Traction avant
Frontantrieb / Tracción delantera

1 x 3 kW AC

REAR STEERING

Sterzata posteriore / Direction arrière
Hintere Lenkung / Dirección trasera

700 W AC - 180°

BATTERY

Batteria / Batterie / Batterie / Batterie

48V - 200 Ah

COUNTERWEIGHTS

Contrappeso / Contrepoids
Gegengewichte / Contrapesos

520 kg

ELECTRO BRAKES

Freni elettrici / Freins electro / ElektroBremse /Frenos electros

25E

MAXIMUM PERFORMANCE AND EQUIPMENTS

Massime prestazioni ed equipaggiamenti
Performances maximales et équipements
Maximale Leistung und Ausrüstung
Máximas prestaciones y equipamiento

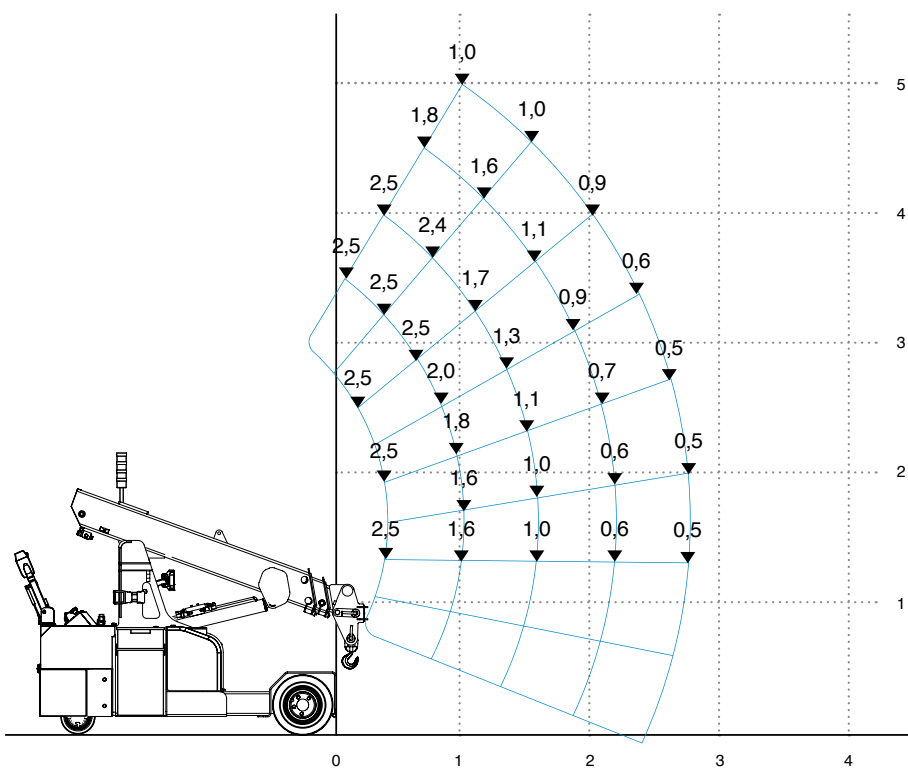

REFERENCE STANDARDS

Normative di riferimento / Normes de référence
Referenzstandards / Estandards de referencia

2006/42 CE
EN 13000

STANDARD

CONTROLS

Comandi / Commandes / Befehle / Comandos

HOOK

Gancio / Crochet / Haken / Gancho

NON-MARKING TIRES

Ruote anti traccia / Roues anti-traces
Nicht-markierende Räder / Ruedas anti-marcas

VARIABLE TILT HEAD

Testa ad inclinazione variabile / Tête à inclinaison variable
Abwinkelbare Spitze / Cabezal ajustable

WINCH

Argano / Treuil / Winde / Cabrestante

MANUAL JIB

Jib manuale / Fléchette manuel / Manueller Ausleger / Pluma manual

RADIO-CONTROL

Radiocomando / Radiocommande / Fernsteuerung / Radio control

AUTOMATIC REFILL

Riempimento automatico / Recharge automatique de liquide
Automatische Nachfüllung / Recarga automatica de liquido

ONBOARD CHARGER

Caricabatterie a bordo / Chargeur embarque / Bordladegerat / Cargadir a bordo

CARRY DECK

Pianale di carico / Plateforme de chargement
Ladeplattform / Plataforma de carga

FRONT ELECTRIC BRAKES

Elettrofreni ruote anteriori / Freins électriques avant
Elektrische Vorderradbremesen / Frenos eléctricos delanteros

LITHIUM BATTERIES

Batterie al litio / Batteries au lithium / Lithiumbatterien / Baterías de litio

ATEX TRANSFORMATION

Trasformazione ATEX / Transformation ATEX
ATEX-Umwandlung / Transformación ATEX

VALLA CONNECT SYSTEM

OPTIONAL

info.valla@tadano.com

www.tadano.com

Tadano Ltd.

Kanda Square 18th Floor, 2-2-1 Kanda-Nishikicho, Chiyoda-ku, Tokyo 101-0054, Japan

Phone: +81-3-6811-7309 (International Division)

Manitex Valla S.R.L.

Via Leonardo da Vinci, 12 29016 - Careco - Piacenza - Italia.

Tel.: +39 0523 256411



Reaching new heights

