



PRODUCT DETAILS

Documentazione tecnica / Détails du produit
Produktdetails/ Detalles de producto

V80R

TECHNICAL INFORMATION

Informazioni tecniche
Informations techniques
Technische information
Información técnica

MAX PAYLOAD

Portata massima / Capacité max
Max Tragfähigkeit / Max capacidad

8000 kg

TOTAL WEIGHT

Peso totale / Poids total
Gesamtgewicht / Peso total

8350 kg

DIMENSIONS

Dimensioni / Dimensions
Abmessungen / Dimensiones

3190 x 1400 x 1895 mm

FRONT

Anteriore / Avant / Vorderrad / Delantera

N° 2 S.E. / 250 – 15”

REAR

Posteriore / Arrière / Hinterrad / Trasera

N° 2 S.E. / 23x9 – 10”

HYDRAULICS

Impianto idraulico (Pressione massima/Potenza motore)
Hydraulique (Pression maxi/Puissance moteur)
Hydraulik (Max Druck/Motorleistung)
Hidraulica (Presion max/Potencia motor)

220 Bar – 12 kW AC

FRONT-WHEEL DRIVE

Trazione anteriore / Traction avant
Frontantrieb / Tracción delantera

2 x 4.2 kW AC

REAR STEERING

Sterzata posteriore / Direction arrière
Hintere Lenkung / Direccion trasera

800W AC - 180°

BATTERY

Batteria / Batterie / Batterie / Batterie

80V - 560 Ah

REMOVABLE COUNTERWEIGHTS

Contrappesi removibili / Contrepoids amovibles
Abnehmbare Gegengewichte / Contrapesos removibles

N° 2 x 1300 kg

FRONT ELECTRO-HYDRAULIC BRAKES

Freni elettroidraulici anteriori / Freins électrohydrauliques avant
Elektrohydraulische Vorderradbrem sen / frenos electrohidráulicos delanteros

STANDARD

NON-MARKING TIRES

Ruote anti traccia / Roues anti-traces
Nicht-markierende Räder / Ruedas anti-marcas

VARIABLE TILT HEAD

Testa ad inclinazione variabile / Tête à inclinaison variable
Abwinkelbare Spitze / Cabezal ajustable

RADIO-CONTROL

Radiocomando / Radiocommande / Fernsteuerung / Radio control

HOOK

Gancio / Crochet / Haken / Gancho

OPTIONAL

STABILIZER CROSSBAR

Barra stabilizzatrice anteriore / Barre stabilisatrice
Vorderradabstützung / Barra estabilizadora

WINCH

Argano / Treuil / Winde / Cabrestante

FOLDABLE MECHANICAL JIB

Jib meccanico ripiegabile / Fléchette mécanique repliable
Klappbarer mechanischer Ausleger / Pluma mecanica plegable

FOLDABLE HYDRAULIC JIB

Jib idraulico ripiegabile / Fléchette hydraulique repliable
Klappbarer hydraulischer Ausleger / Pluma hidráulica plegable

SELF-LEVELLING FORKS

Forche autolivellanti / Fourches à nivellement automatique
Selbstnivellierende Gabeln / Horquillas autonivelantes

LITHIUM BATTERIES

Batterie al litio / Batteries au lithium
Lithiumbatterien / Baterías de litio

ATEX TRANSFORMATION

Trasformazione ATEX / Transformation ATEX
ATEX-Umwandlung / Transformación ATEX

VALLA CONNECT SYSTEM

V80R

OVERALL SIZE

Dimensioni d'ingombro

Dimensions globales

Gesamtgröße

Dimensiones totales

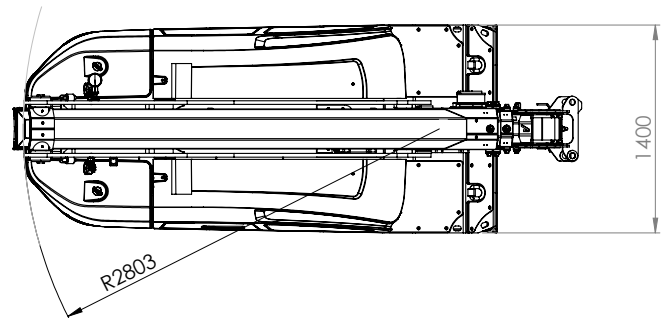
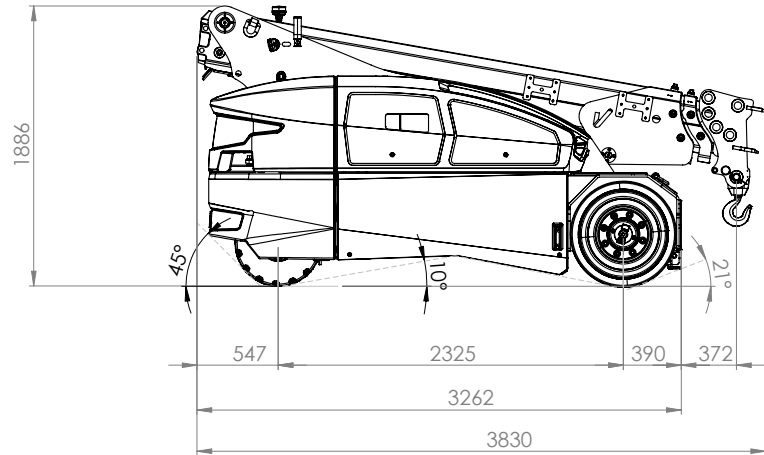
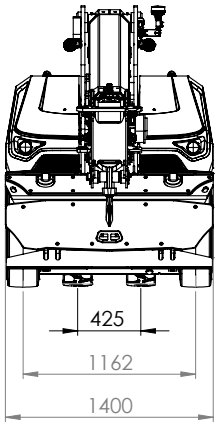

V80R



OVERALL SIZE

Dimensioni d'ingombro

Dimensions globales

Gesamtgröße

Dimensiones totales

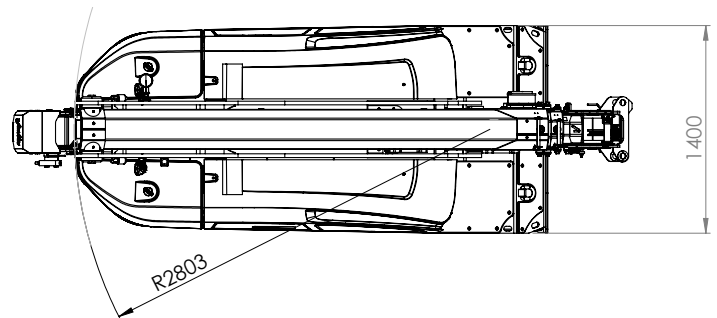
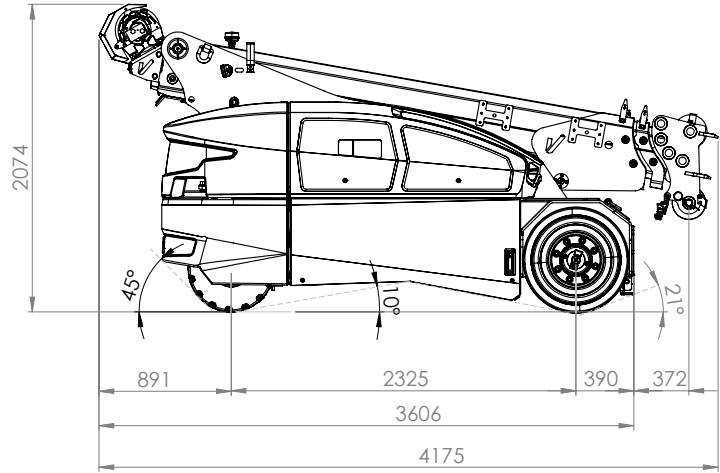
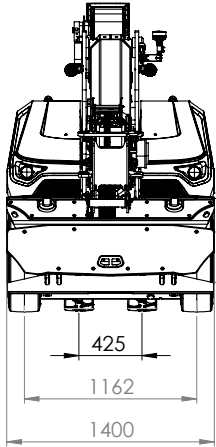

V80R

OVERALL SIZE

Dimensioni d'ingombro

Dimensions globales

Gesamtgröße

Dimensiones totales

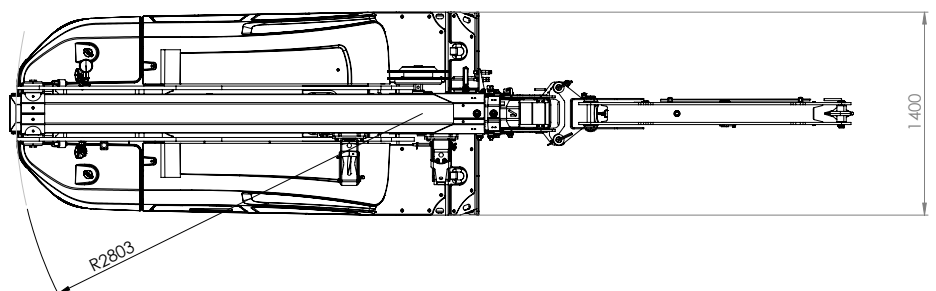
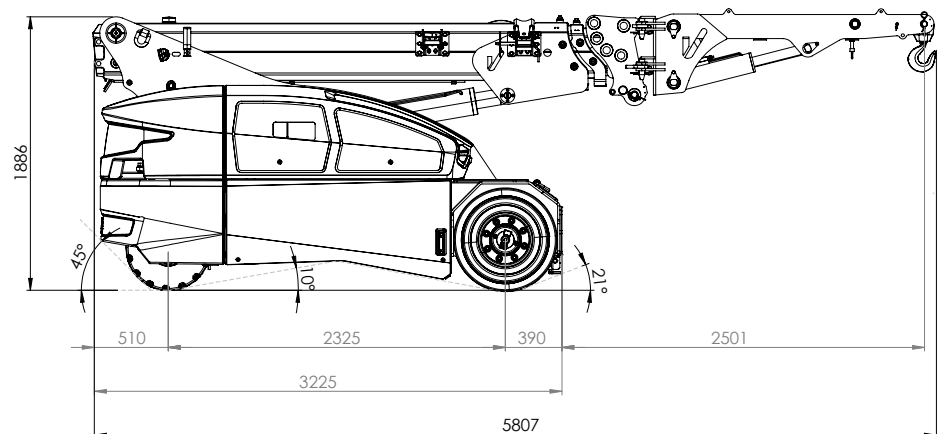
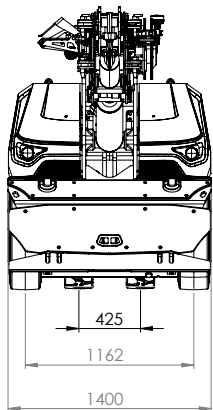
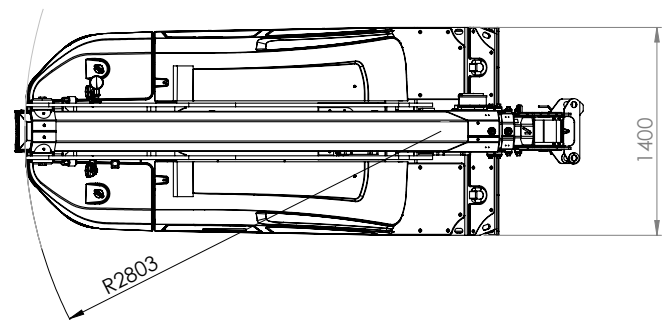
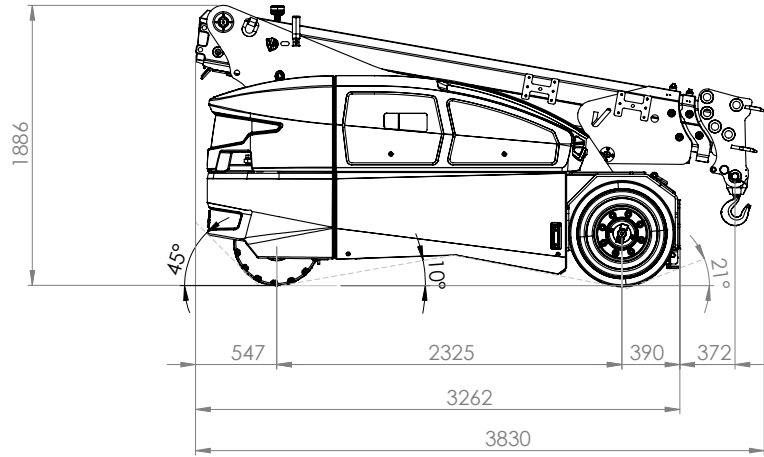
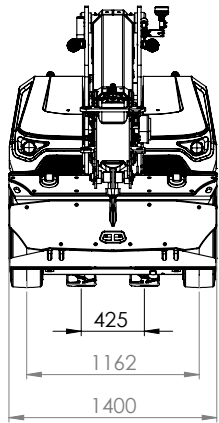

V80R

OVERALL SIZE

Dimensioni d'ingombro

Dimensions globales

Gesamtgröße

Dimensiones totales

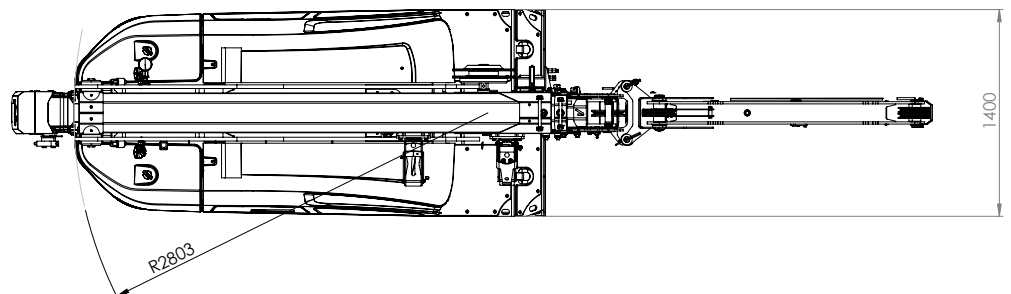
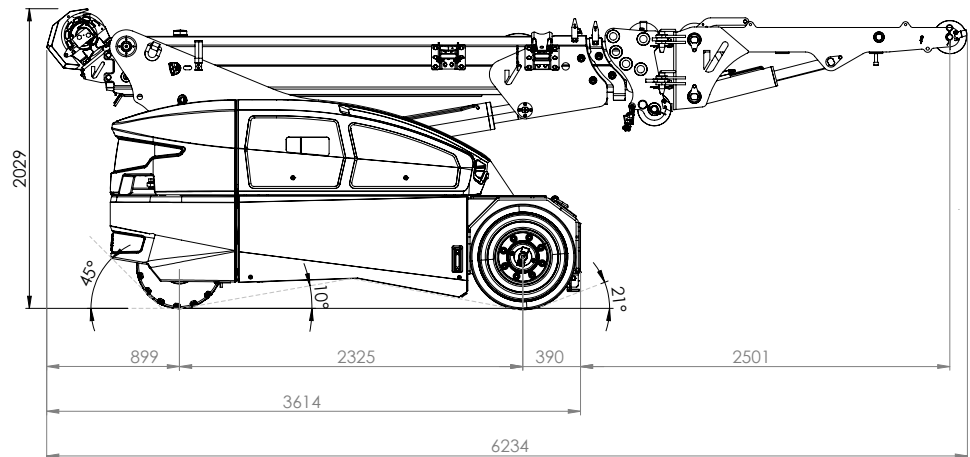
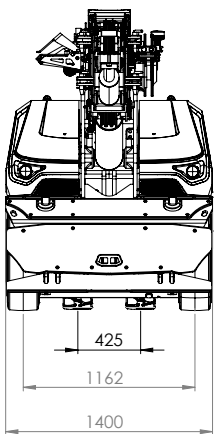
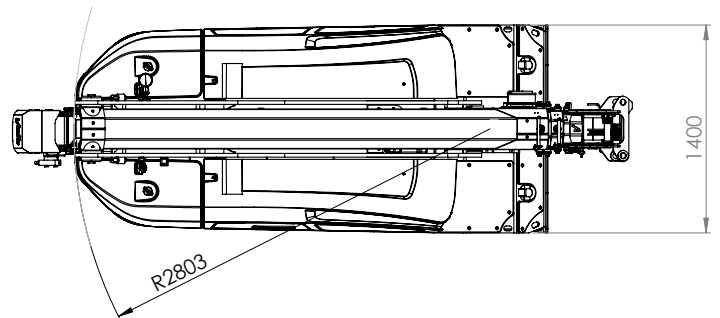
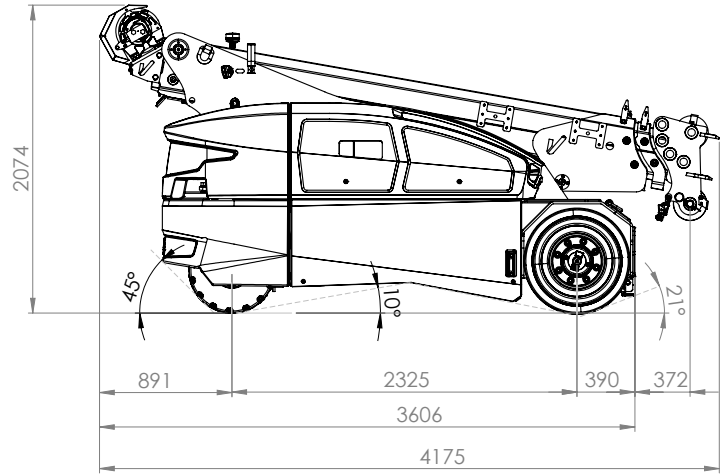
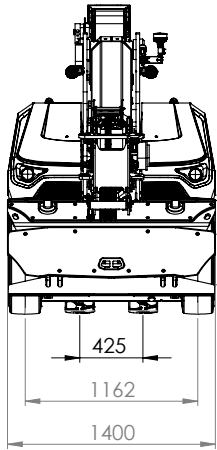

V80R



OVERALL SIZE

Dimensioni d'ingombro
Dimensions globales
Gesamtgröße
Dimensiones totales

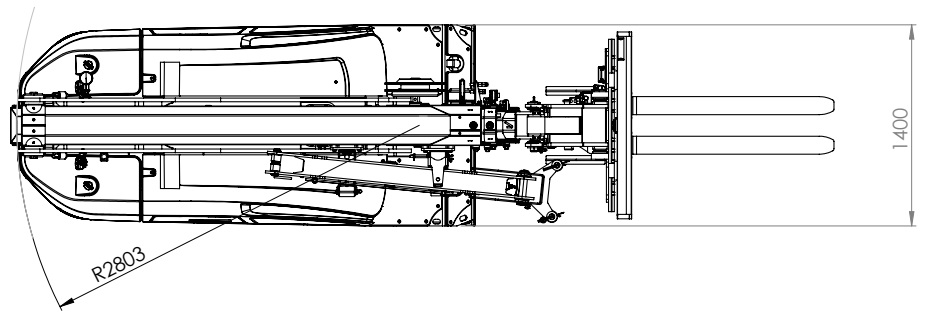
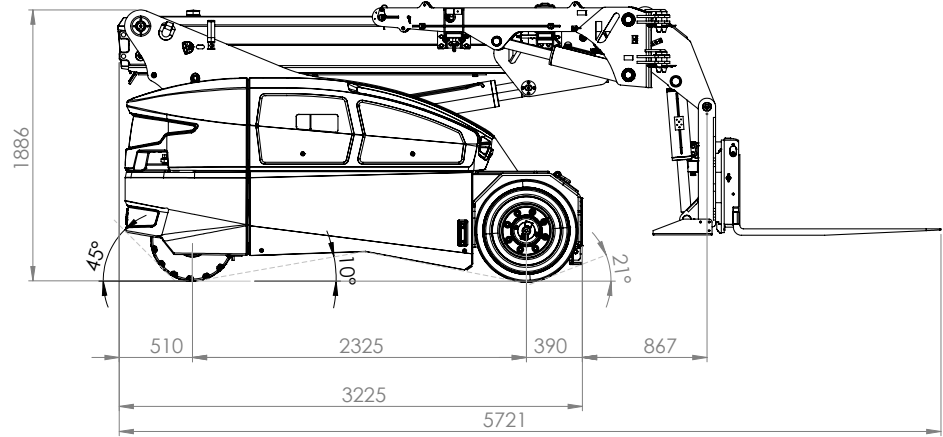
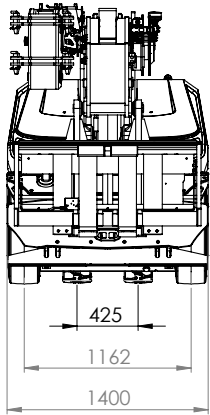

V80R

LOAD DIAGRAM (t)

Diagramma di carico (t)
 Tableau de charges utiles (t)
 Traglastdiagramm (t) / Lastendiagramm (t)
 Diagrama de las capacidades de carga (t)



POS. 1
 COD. 188.350.REV B

UNI EN 13000:2014
 ISO 4305:2014

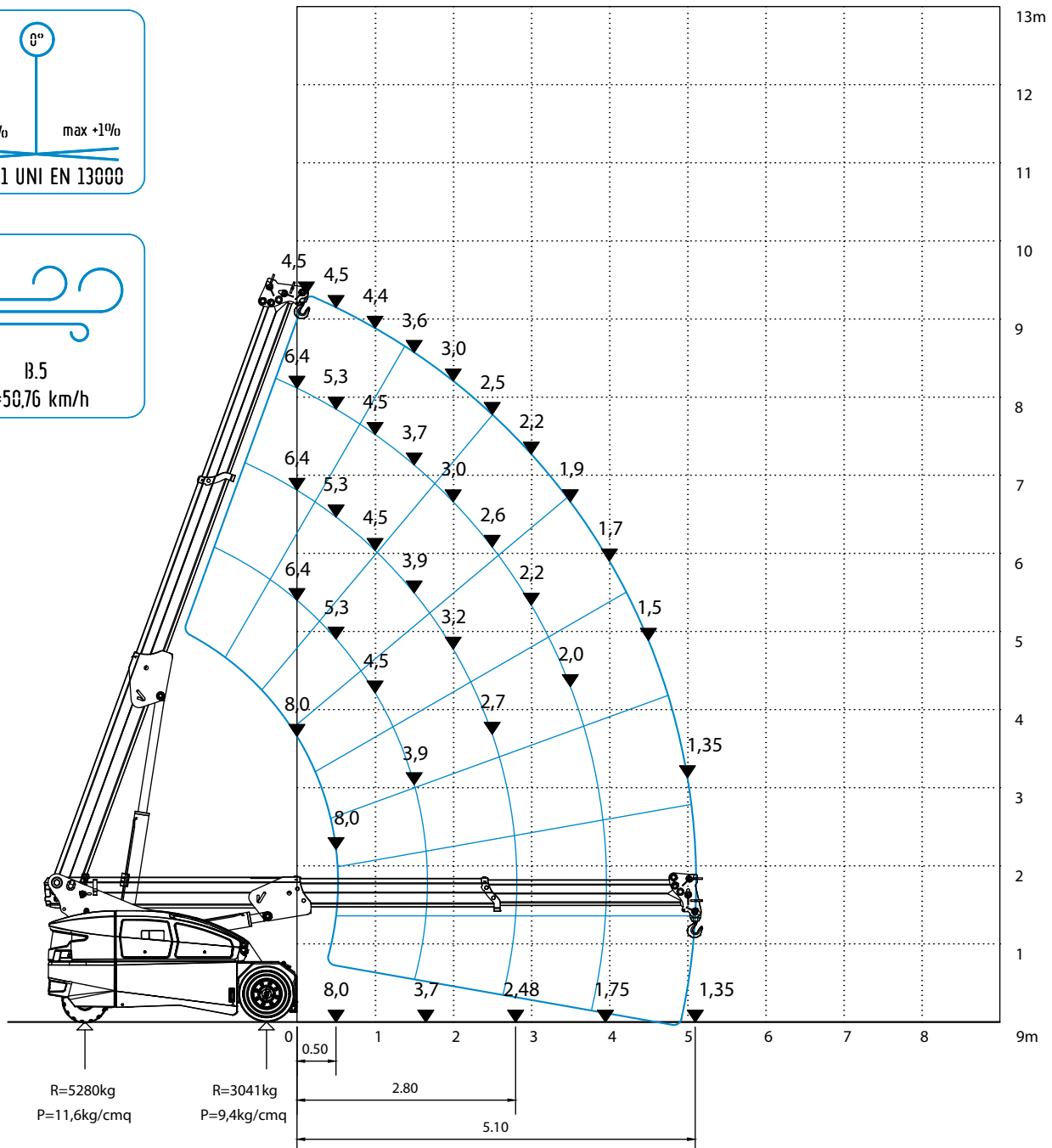
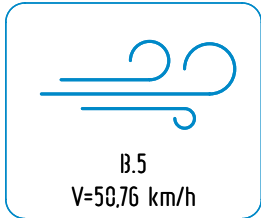
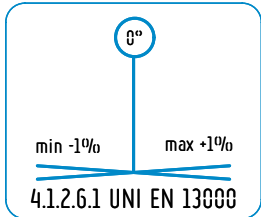

V80R

LOAD DIAGRAM (t)

Diagramma di carico (t)
 Tableau de charges utiles (t)
 Traglastdiagramm (t) / Lastendiagramm (t)
 Diagrama de las capacidades de carga (t)



POS. 2
 COD. 188.350.REV B

UNI EN 13000:2014
 ISO 4305:2014

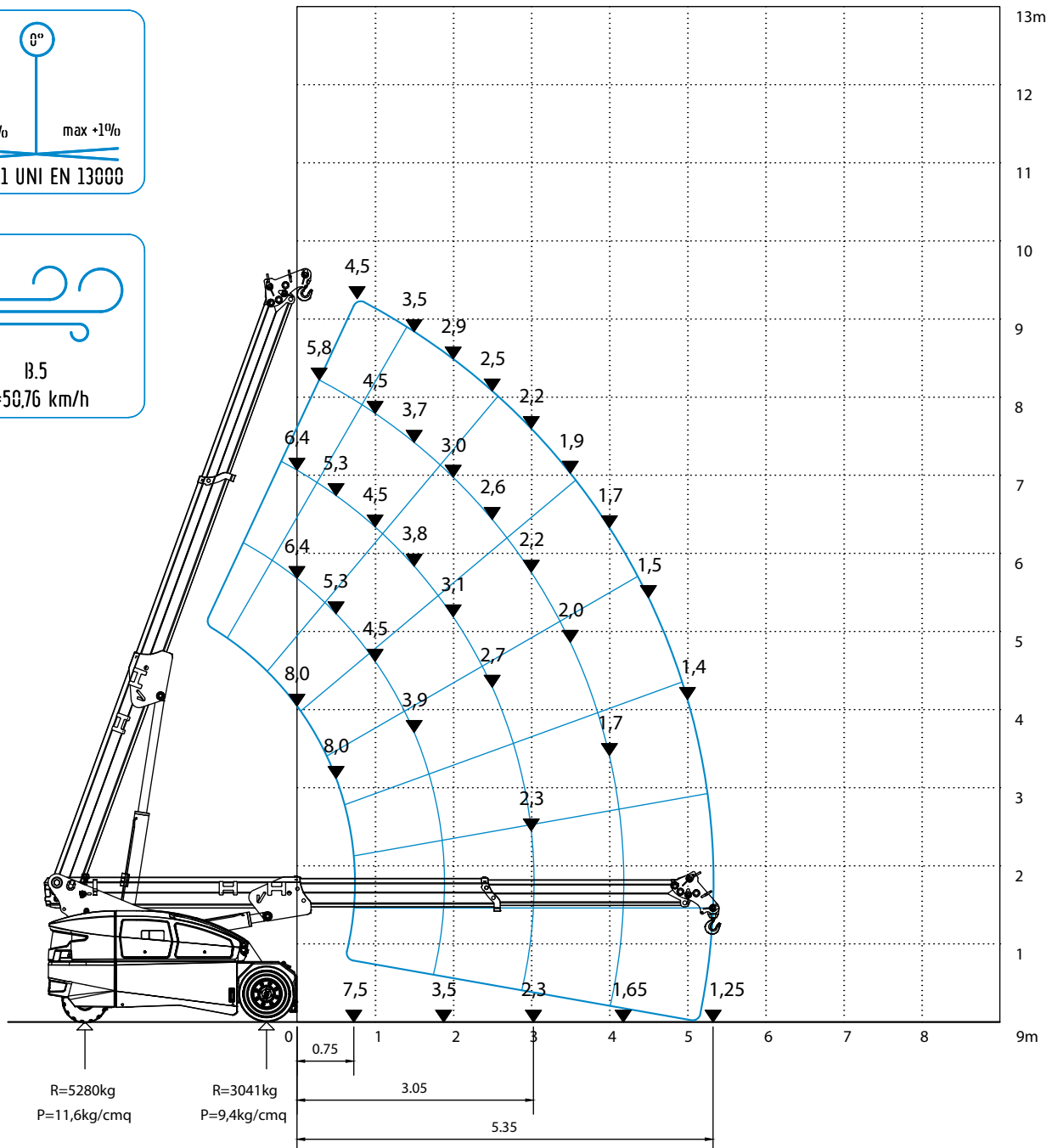
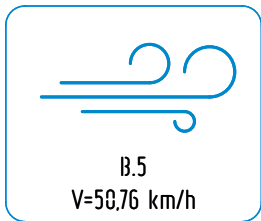
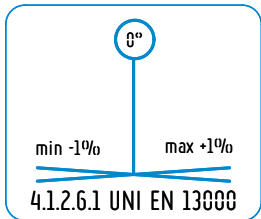

V80R

LOAD DIAGRAM (t)

Diagramma di carico (t)
 Tableau de charges utiles (t)
 Traglastdiagramm (t) / Lastendiagramm (t)
 Diagrama de las capacidades de carga (t)



POS. 3
 COD. 188.350.REV B

UNI EN 13000:2014
 ISO 4305:2014

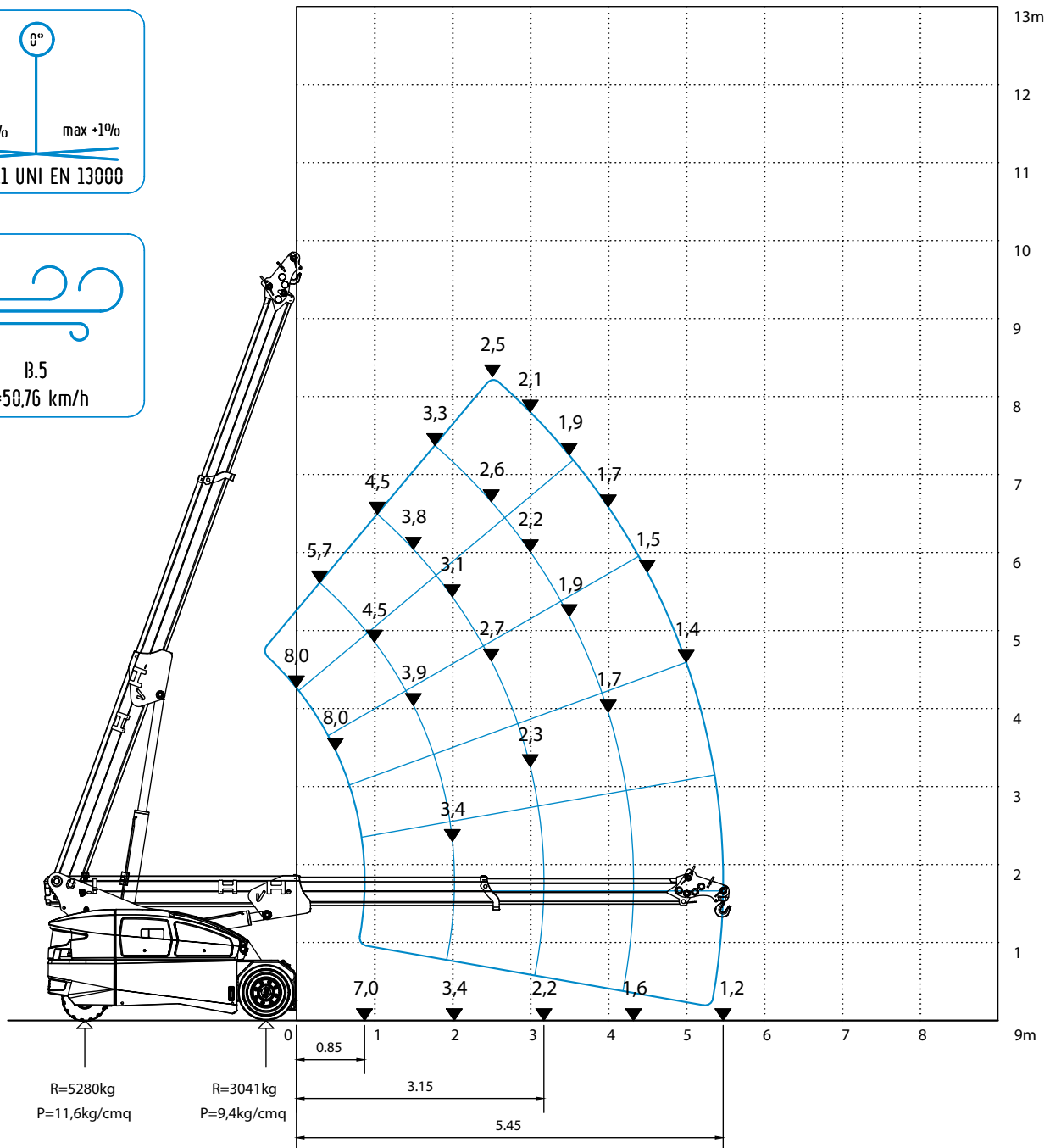
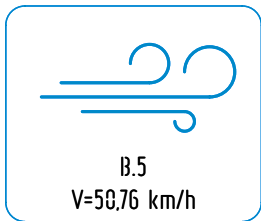
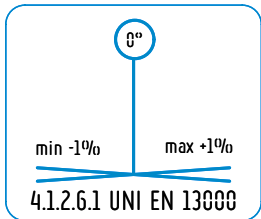

R=5280kg
 P=11,6kg/cm²

R=3041kg
 P=9,4kg/cm²

V80R

LOAD DIAGRAM (t)

Diagramma di carico (t)
 Tableau de charges utiles (t)
 Traglastdiagramm (t) / Lastendiagramm (t)
 Diagrama de las capacidades de carga (t)



POS. 4
 COD. 188.350.REV B

UNI EN 13000:2014
 ISO 4305:2014

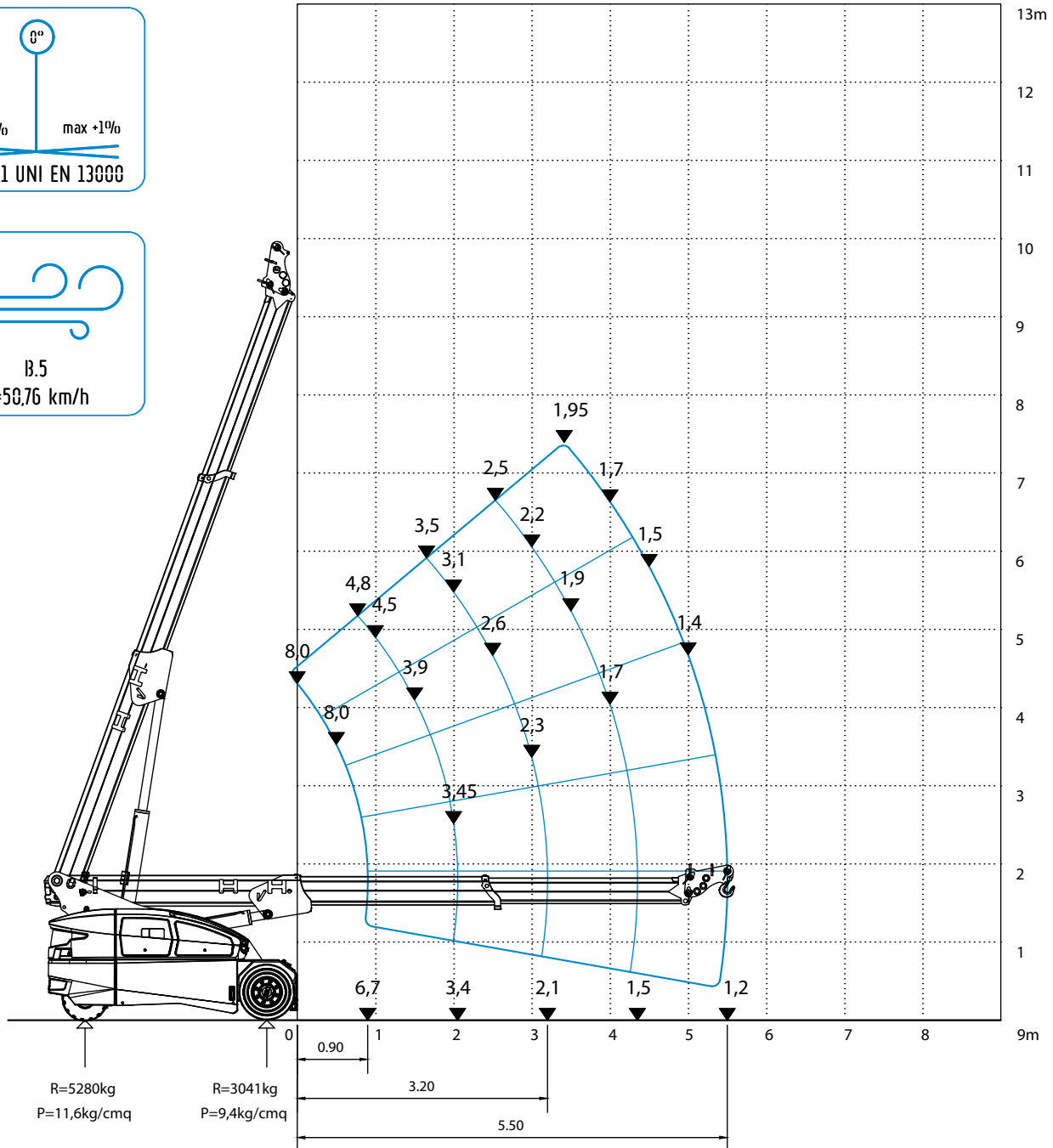
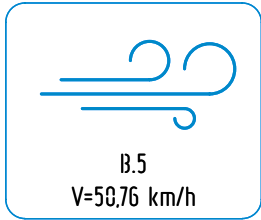
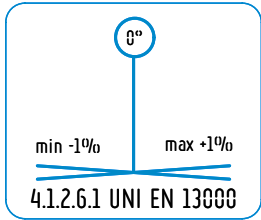

V80R

LOAD DIAGRAM (t)

Diagramma di carico (t)
 Tableau de charges utiles (t)
 Traglastdiagramm (t) / Lastendiagramm (t)
 Diagrama de las capacidades de carga (t)



POS. 1
 COD. 188.351.REV A

UNI EN 13000:2014
 ISO 4305:2014

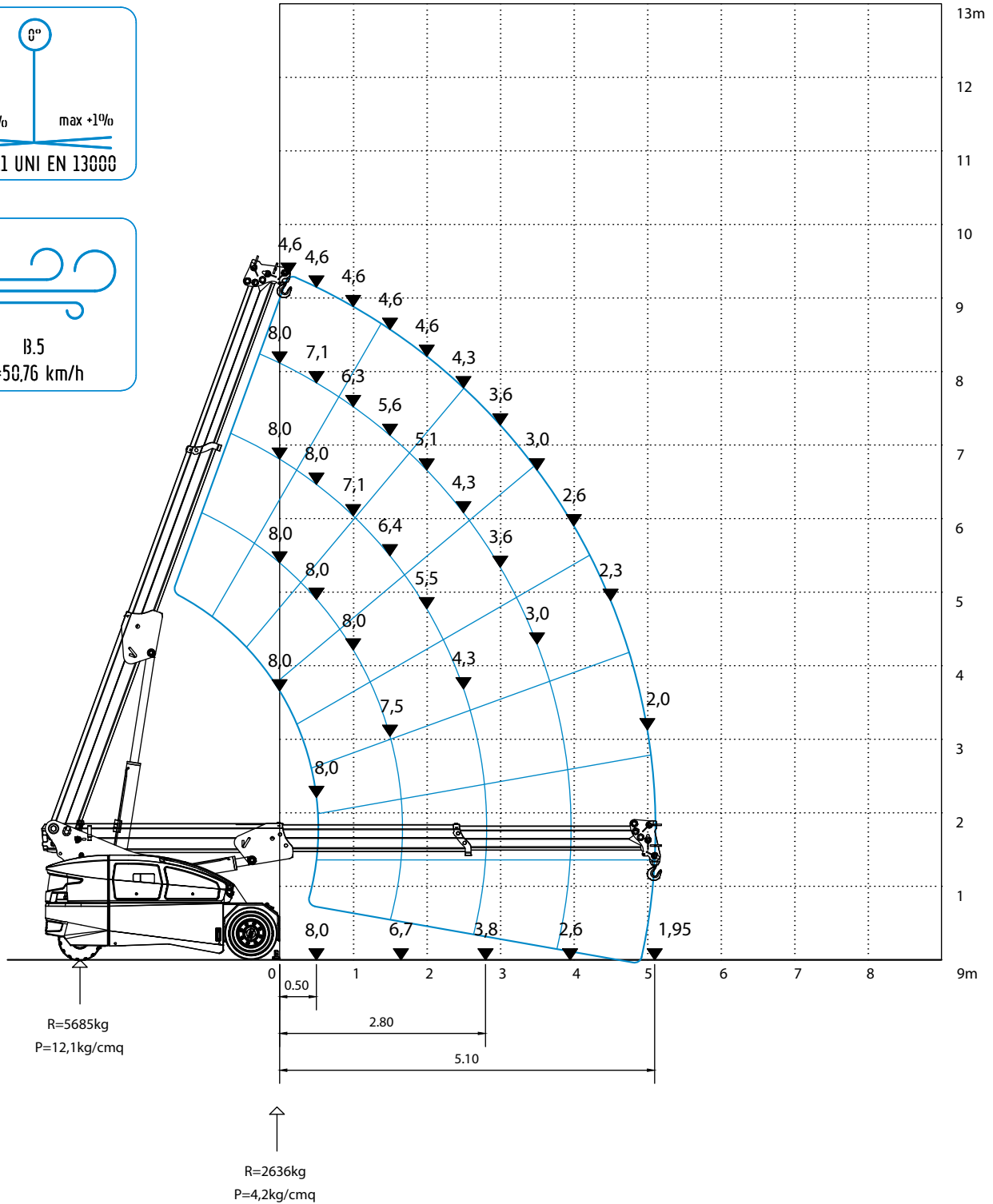
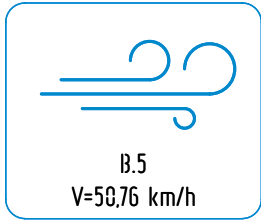
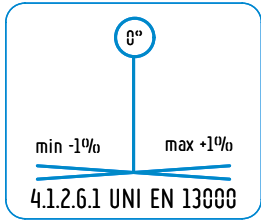

V80R

LOAD DIAGRAM (t)

Diagramma di carico (t)
 Tableau de charges utiles (t)
 Traglastdiagramm (t) / Lastendiagramm (t)
 Diagrama de las capacidades de carga (t)



POS. 2
 COD. 188.351.REV A

UNI EN 13000:2014
 ISO 4305:2014

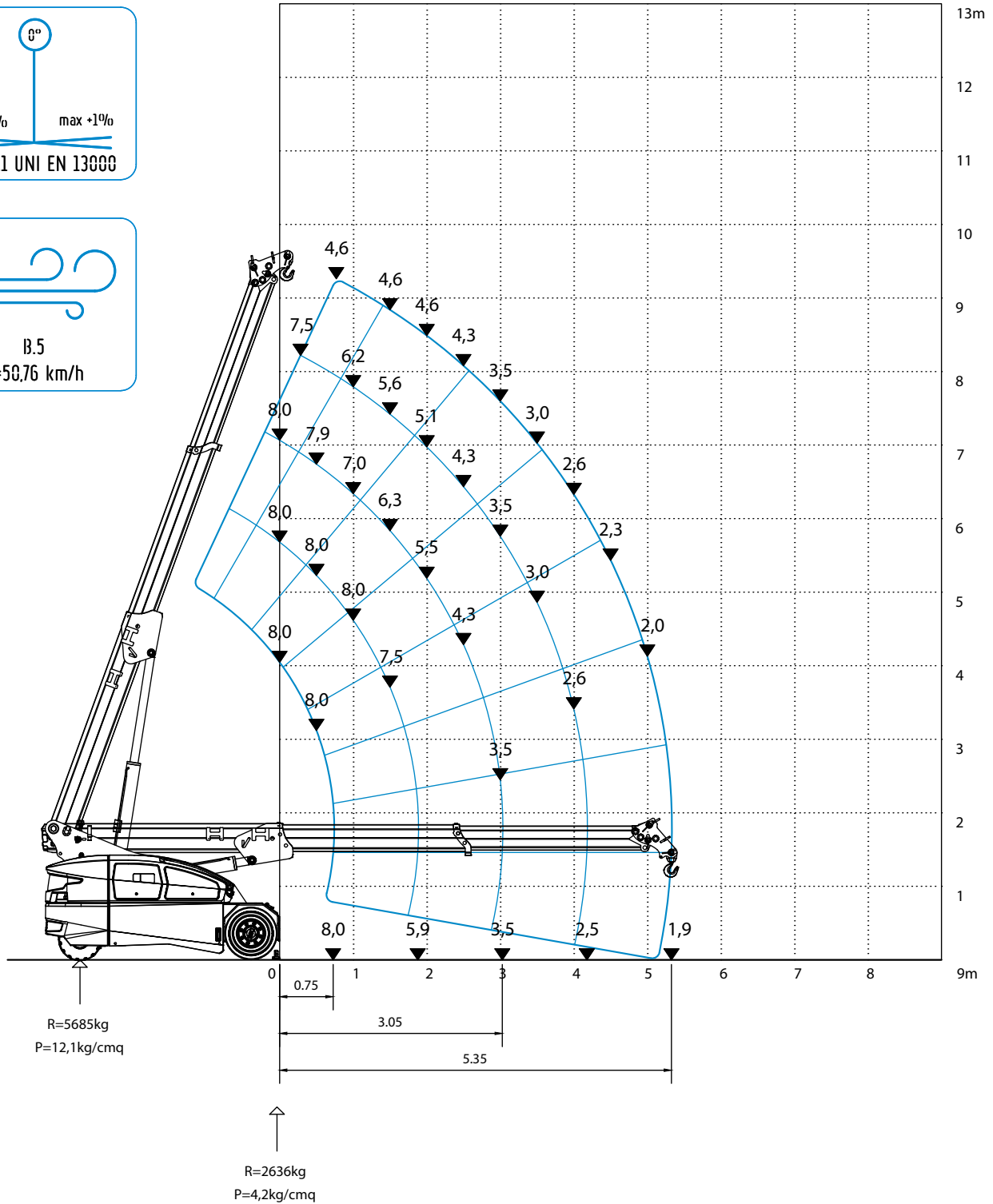
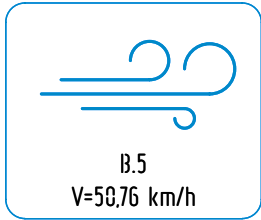
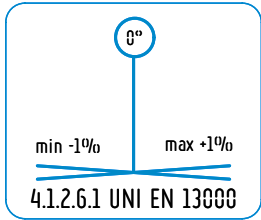

V80R

LOAD DIAGRAM (t)

Diagramma di carico (t)
 Tableau de charges utiles (t)
 Traglastdiagramm (t) / Lastendiagramm (t)
 Diagrama de las capacidades de carga (t)



POS. 3
 COD. 188.351.REV A

UNI EN 13000:2014
 ISO 4305:2014

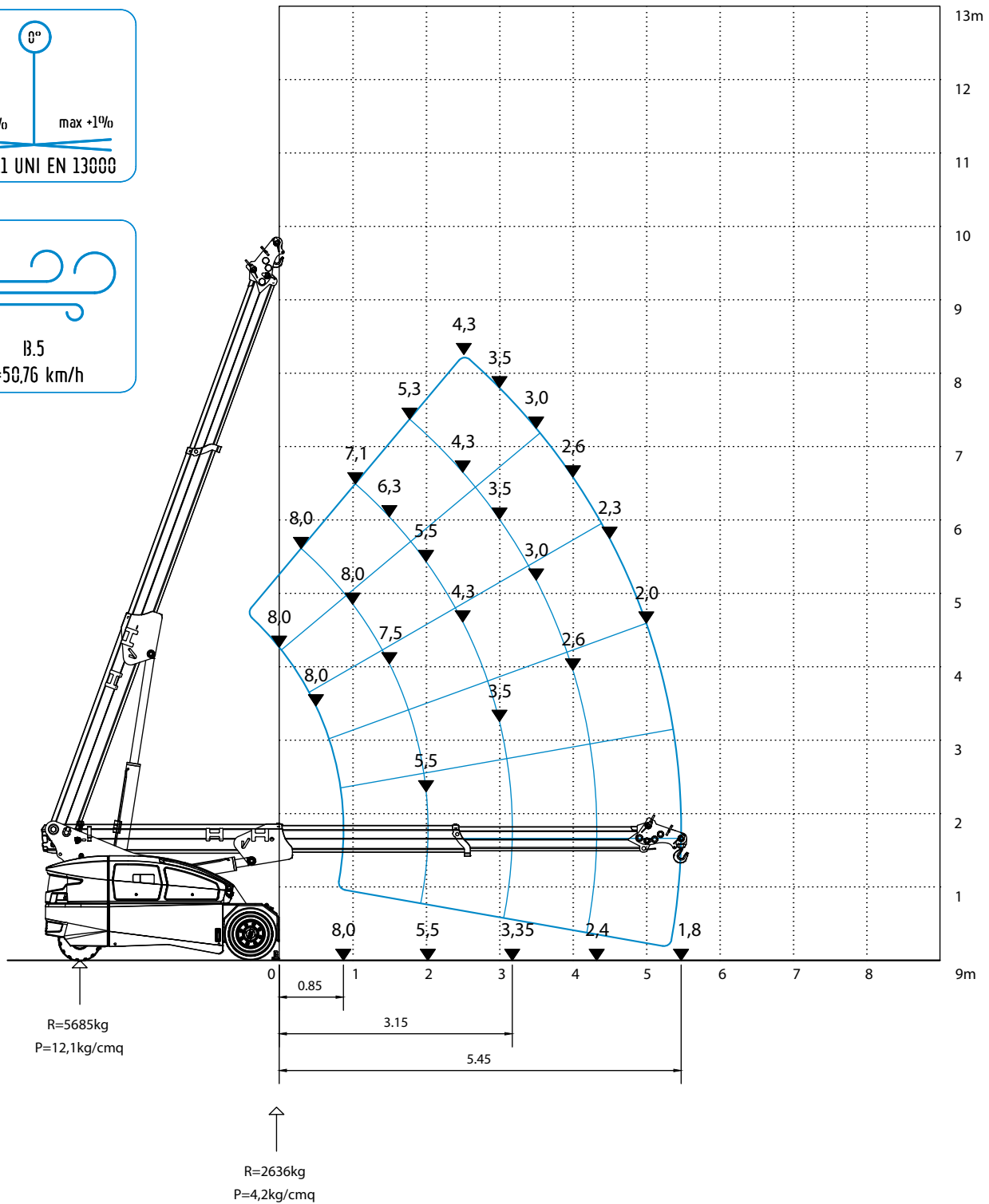
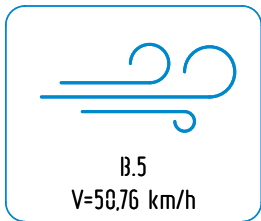
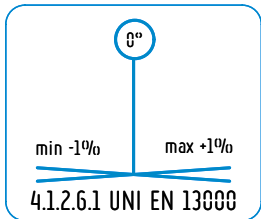

V80R

LOAD DIAGRAM (t)

Diagramma di carico (t)
 Tableau de charges utiles (t)
 Traglastdiagramm (t) / Lastendiagramm (t)
 Diagrama de las capacidades de carga (t)



POS. 4
 COD. 188.351.REV A

UNI EN 13000:2014
 ISO 4305:2014

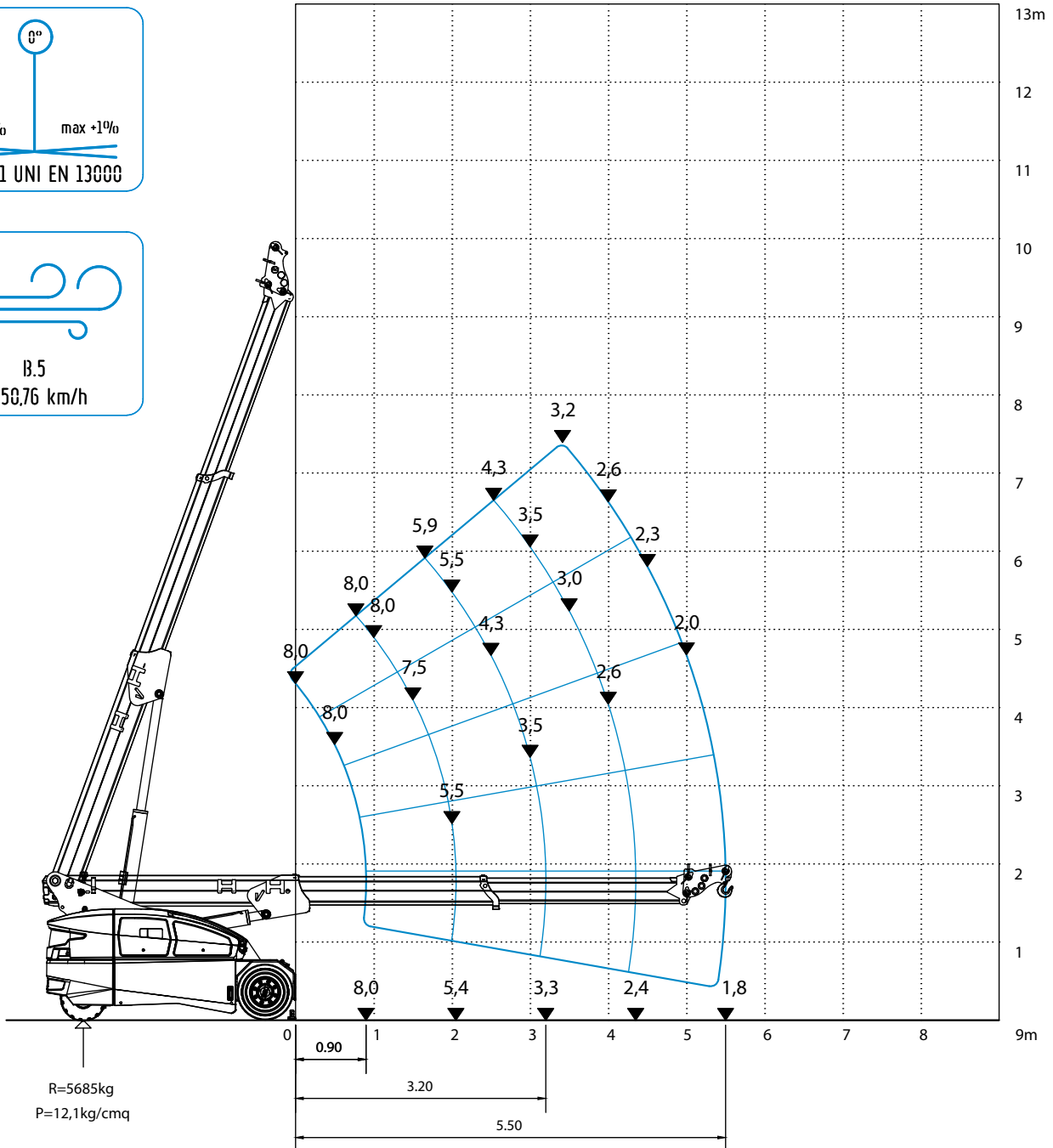
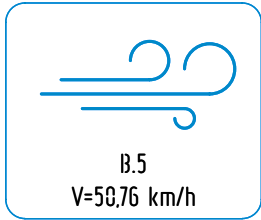
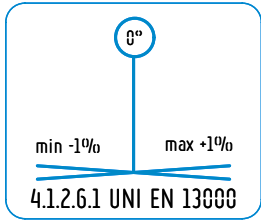

V80R

LOAD DIAGRAM (t)

Diagramma di carico (t)
 Tableau de charges utiles (t)
 Traglastdiagramm (t) / Lastendiagramm (t)
 Diagrama de las capacidades de carga (t)



POS. 1
 COD. 188.352.REV B

UNI EN 13000:2014
 ISO 4305:2014

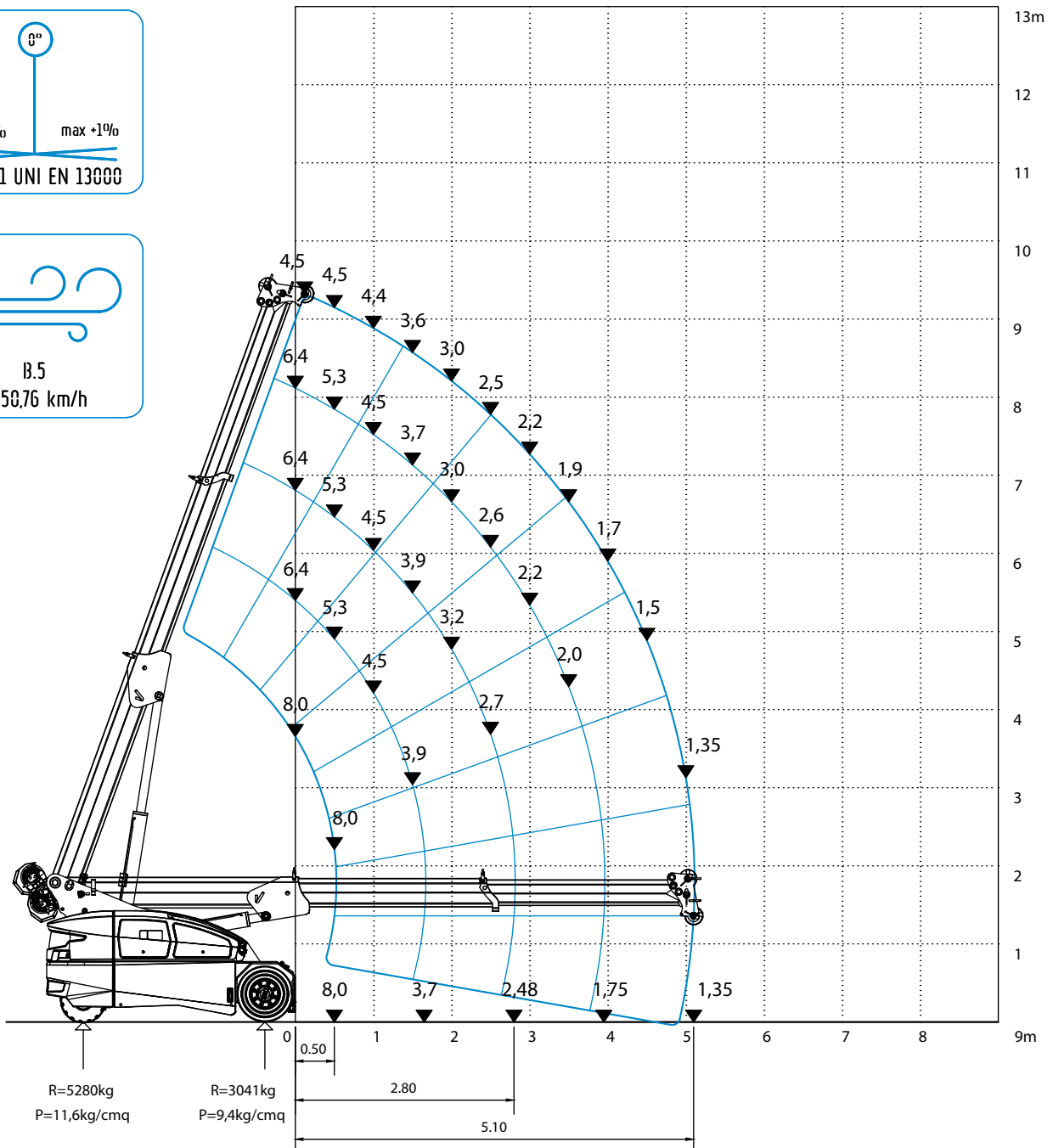
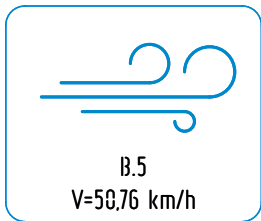
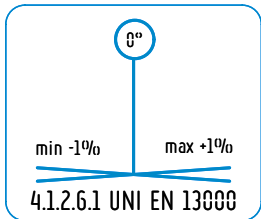

V80R

LOAD DIAGRAM (t)

Diagramma di carico (t)
 Tableau de charges utiles (t)
 Traglastdiagramm (t) / Lastendiagramm (t)
 Diagrama de las capacidades de carga (t)



POS. 1
 COD. 188.353.REV A

UNI EN 13000:2014
 ISO 4305:2014

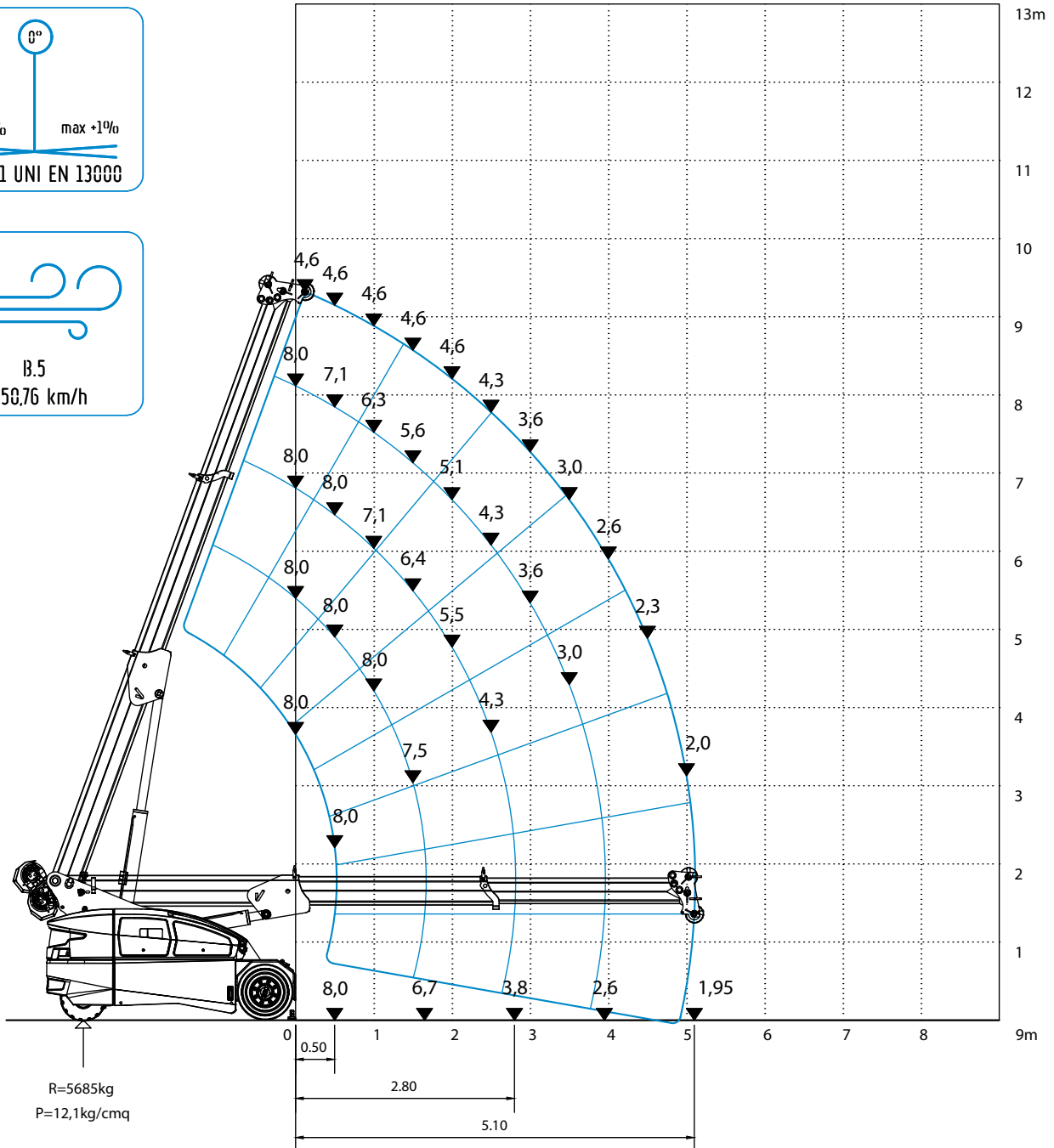
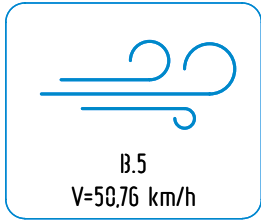
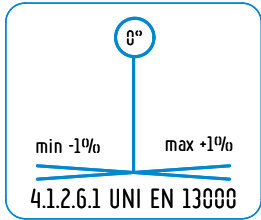

V80R

LOAD DIAGRAM (t)

Diagramma di carico (t)
 Tableau de charges utiles (t)
 Traglastdiagramm (t) / Lastendiagramm (t)
 Diagrama de las capacidades de carga (t)



COD. 188.354.REV A

UNI EN 13000:2014
 ISO 4305:2014

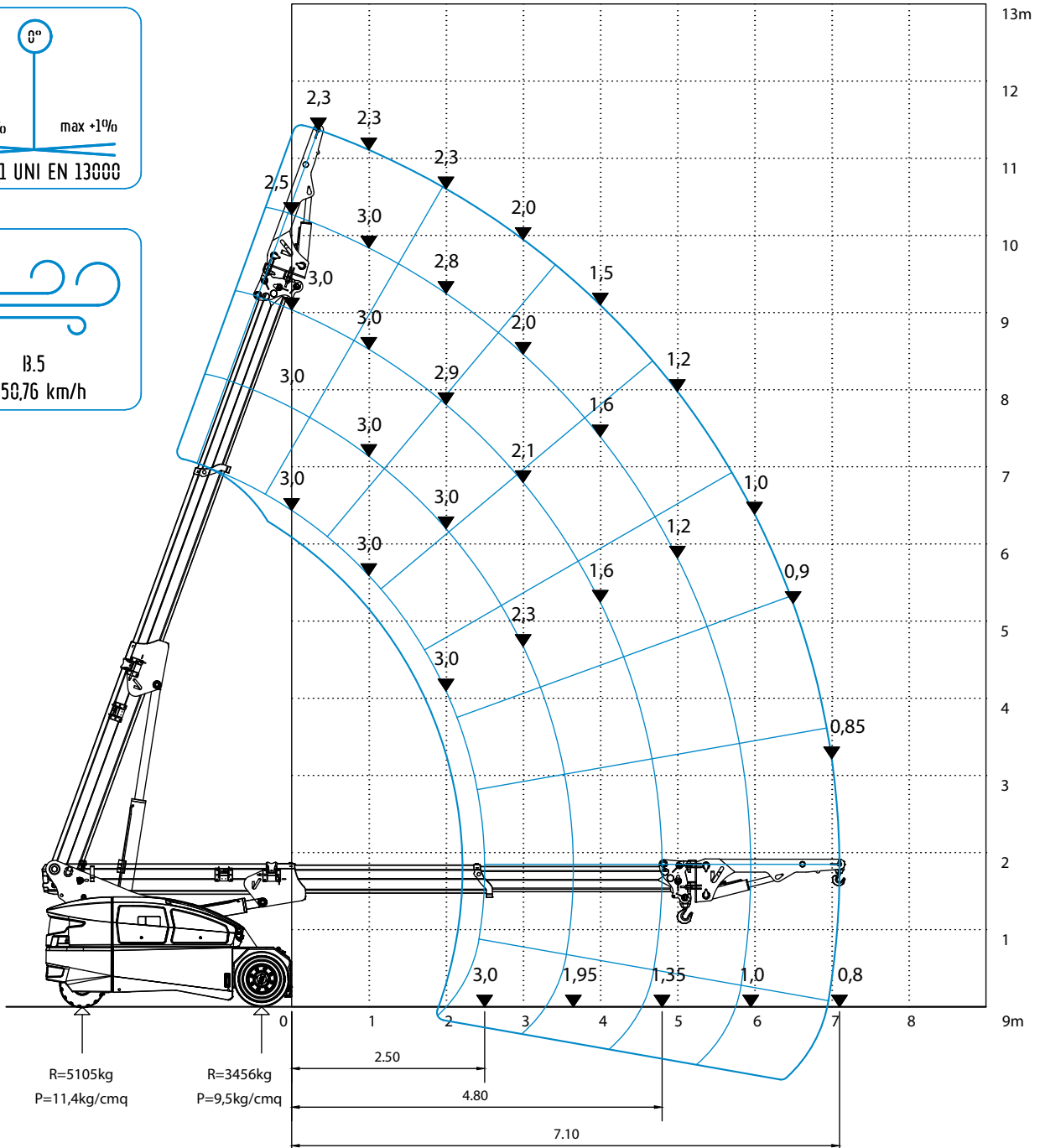
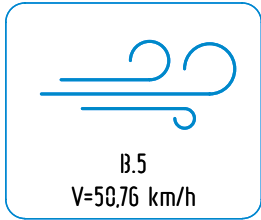
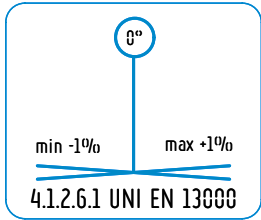

V80R

LOAD DIAGRAM (t)

Diagramma di carico (t)
 Tableau de charges utiles (t)
 Traglastdiagramm (t) / Lastendiagramm (t)
 Diagrama de las capacidades de carga (t)



COD. 188.356.REV A

UNI EN 13000:2014
 ISO 4305:2014

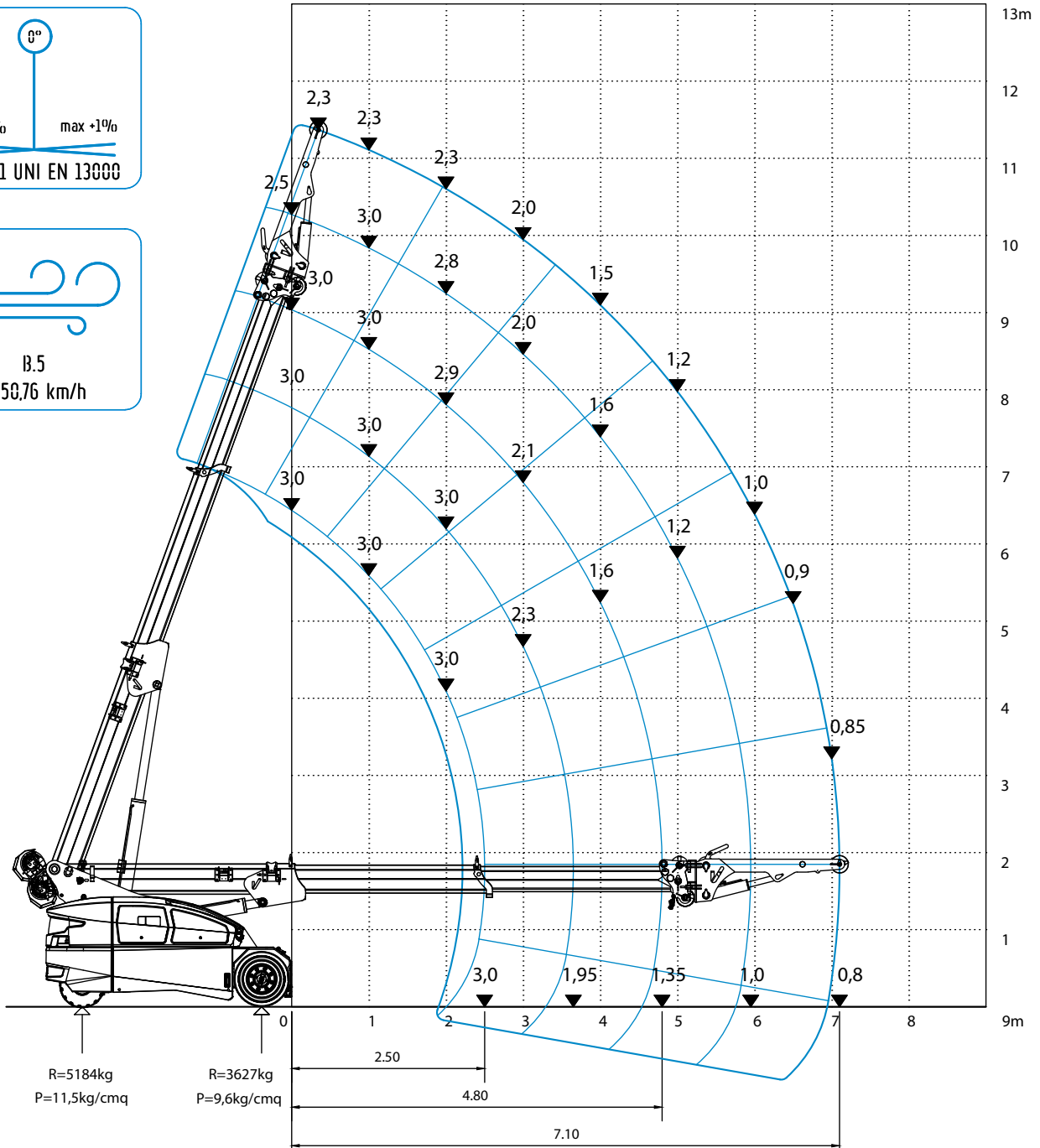
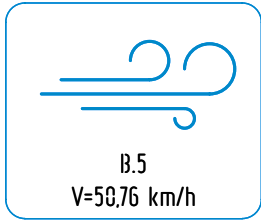
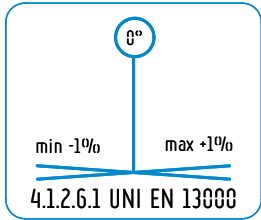

V80R

LOAD DIAGRAM (t)

Diagramma di carico (t)
 Tableau de charges utiles (t)
 Traglastdiagramm (t) / Lastendiagramm (t)
 Diagrama de las capacidades de carga (t)



COD. 188.357.REV A

UNI EN 13000:2014
 ISO 4305:2014

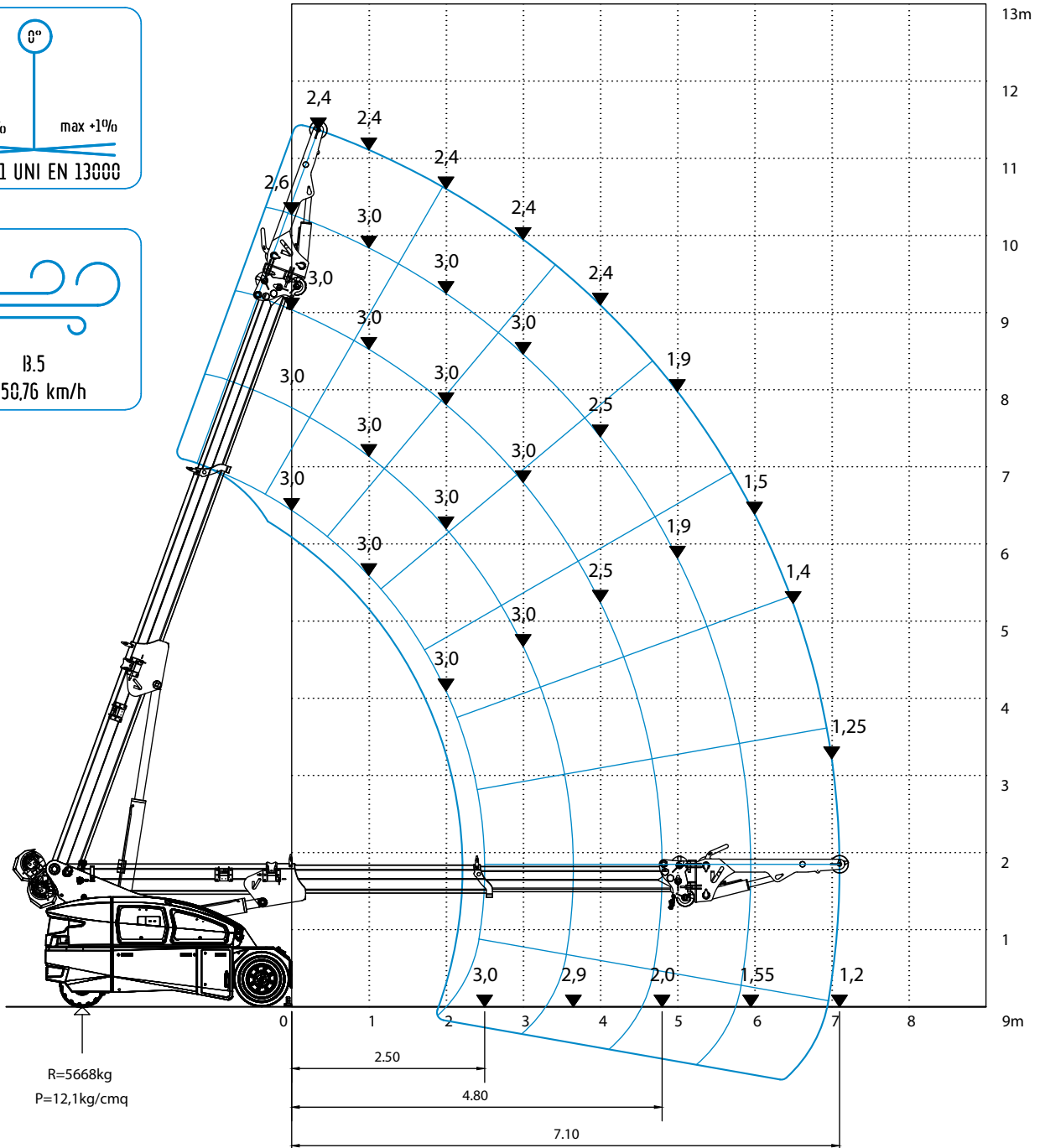
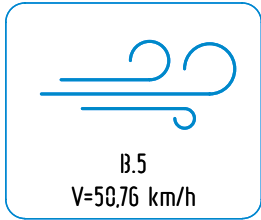
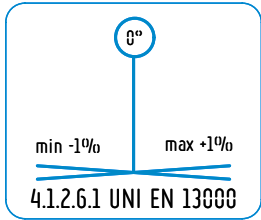

V80R

LOAD DIAGRAM (t)

Diagramma di carico (t)
 Tableau de charges utiles (t)
 Traglastdiagramm (t) / Lastendiagramm (t)
 Diagrama de las capacidades de carga (t)



COD. 188.358.REV A

UNI EN 13000:2014
 ISO 4305:2014

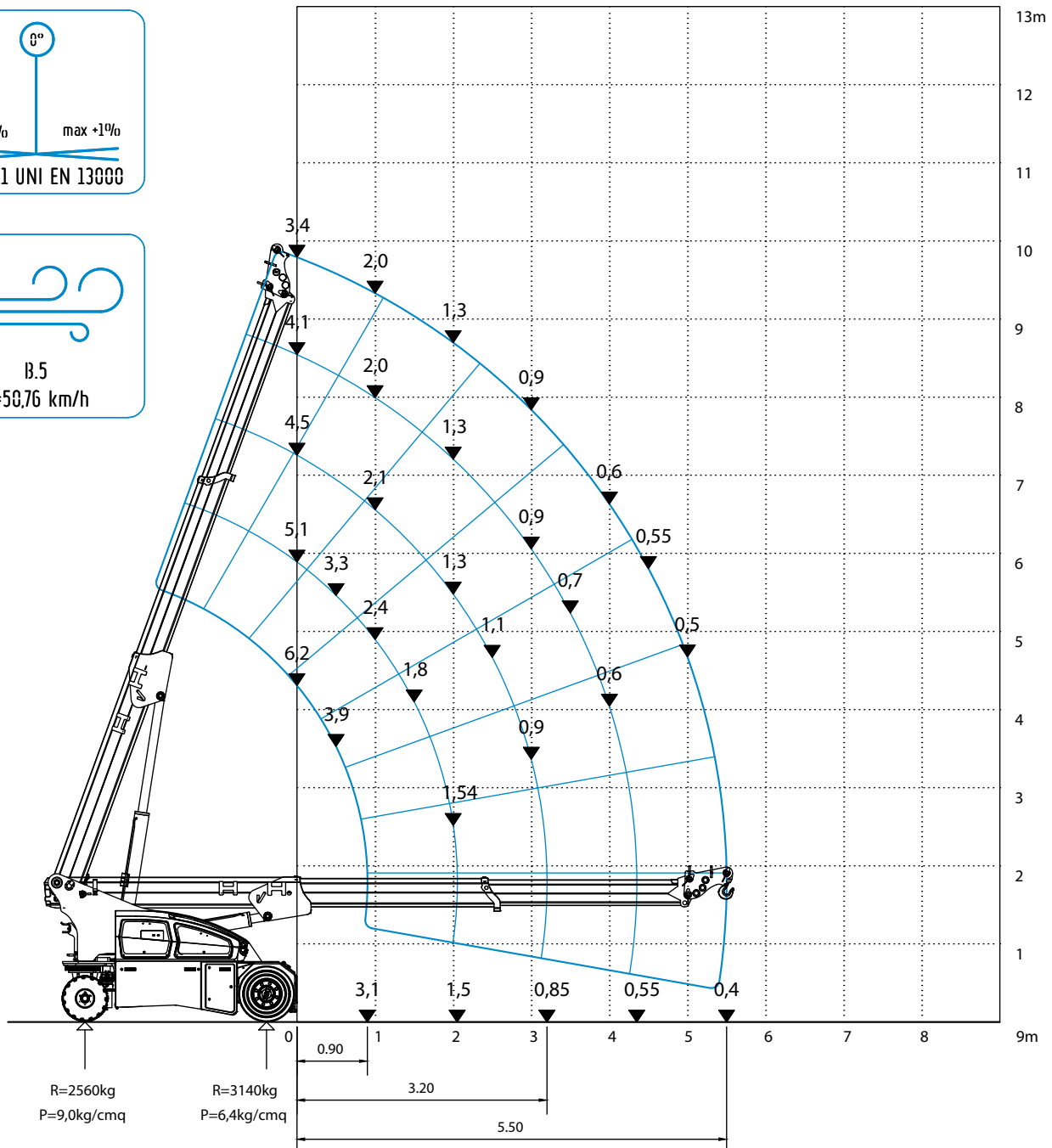
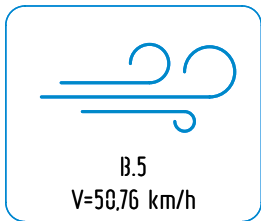
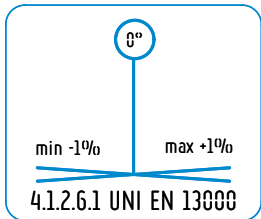

V80R

LOAD DIAGRAM (t)

Diagramma di carico (t)
 Tableau de charges utiles (t)
 Traglastdiagramm (t) / Lastendiagramm (t)
 Diagrama de las capacidades de carga (t)



COD. 188.359.REV A

UNI EN 13000:2014
 ISO 4305:2014

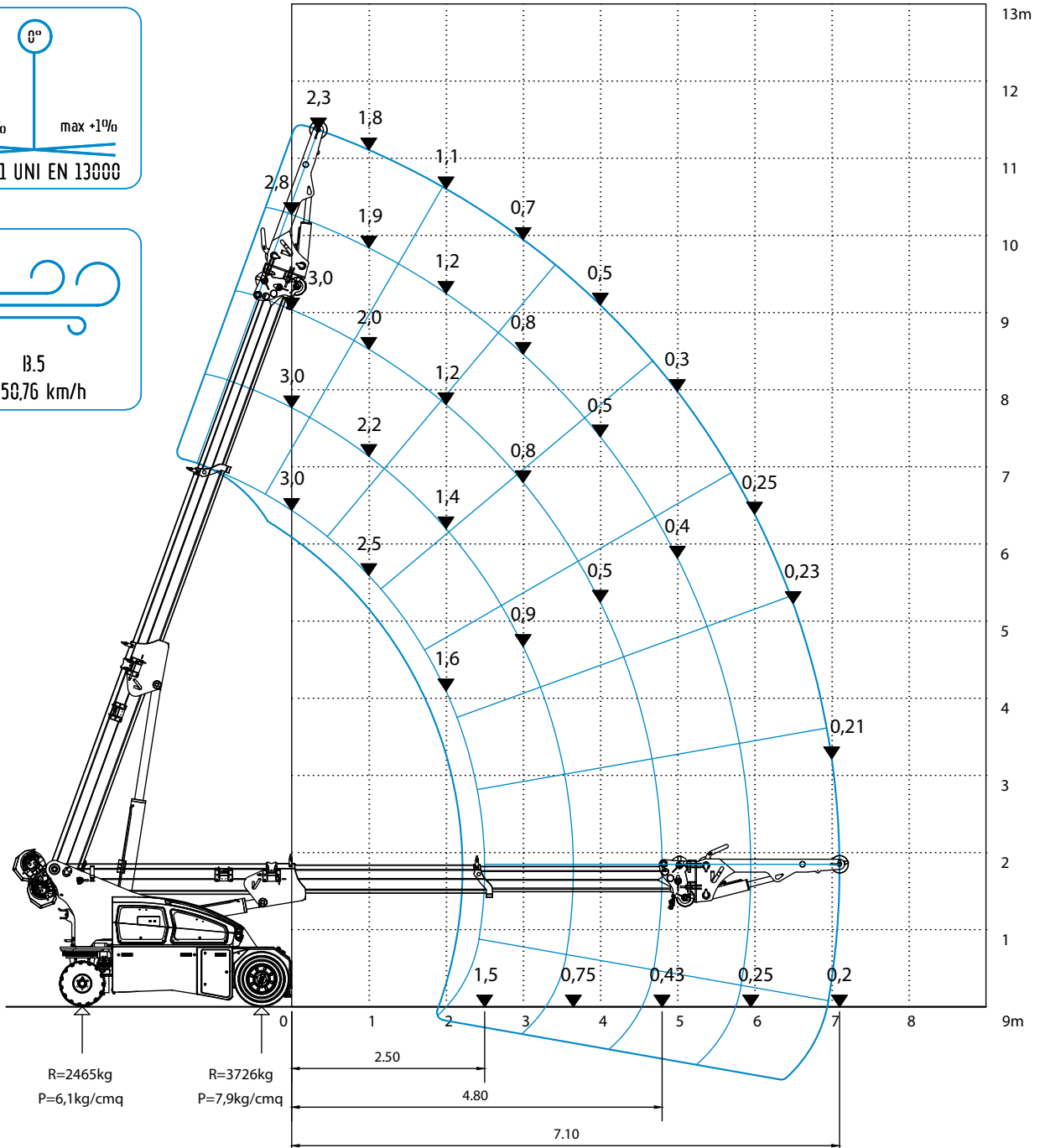
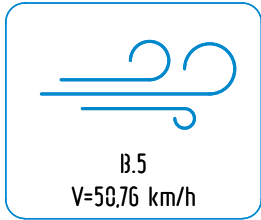
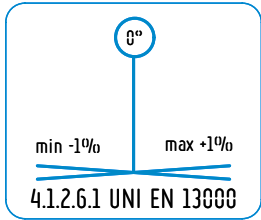

V80R

LOAD DIAGRAM (t)

Diagramma di carico (t)
 Tableau de charges utiles (t)
 Traglastdiagramm (t) / Lastendiagramm (t)
 Diagrama de las capacidades de carga (t)



600
 COD. 188.360.REV A

UNI EN 13000:2014
 ISO 4305:2014

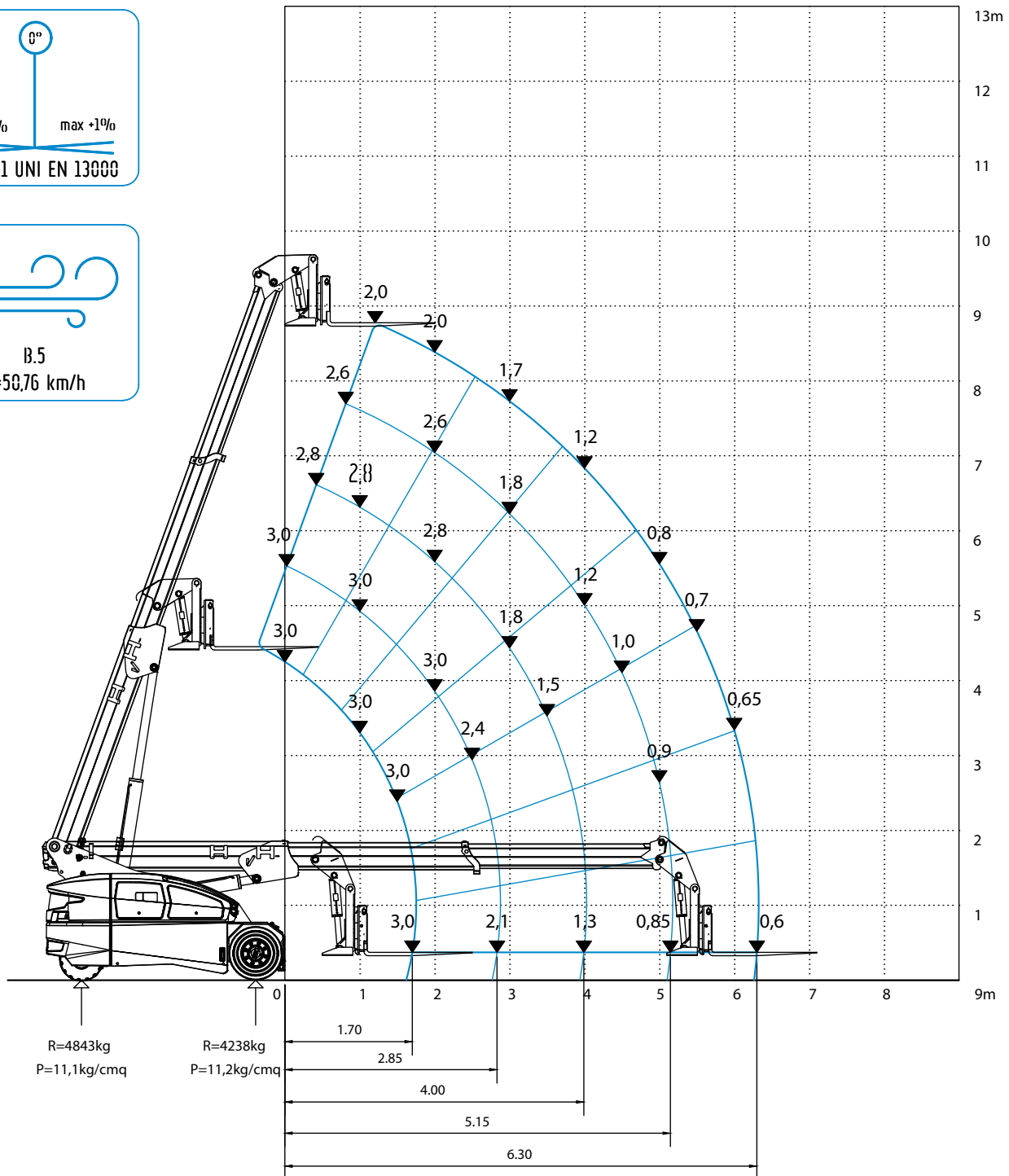
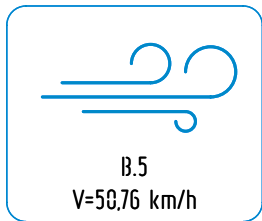
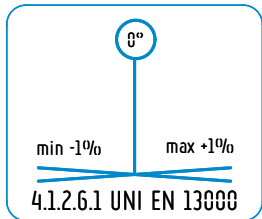

info.valla@tadano.com

www.tadano.com

Tadano Ltd.

Kanda Square 18th Floor, 2-2-1 Kanda-Nishikicho, Chiyoda-ku, Tokyo 101-0054, Japan

Phone: +81-3-6811-7309 (International Division)

Manitex Valla S.R.L.

Via Leonardo da Vinci, 12 29016 - Careco - Piacenza - Italia.

Tel.: +39 0523 256411

