

AC 2.040-1

40 US TON MAX. CRANE CAPACITY

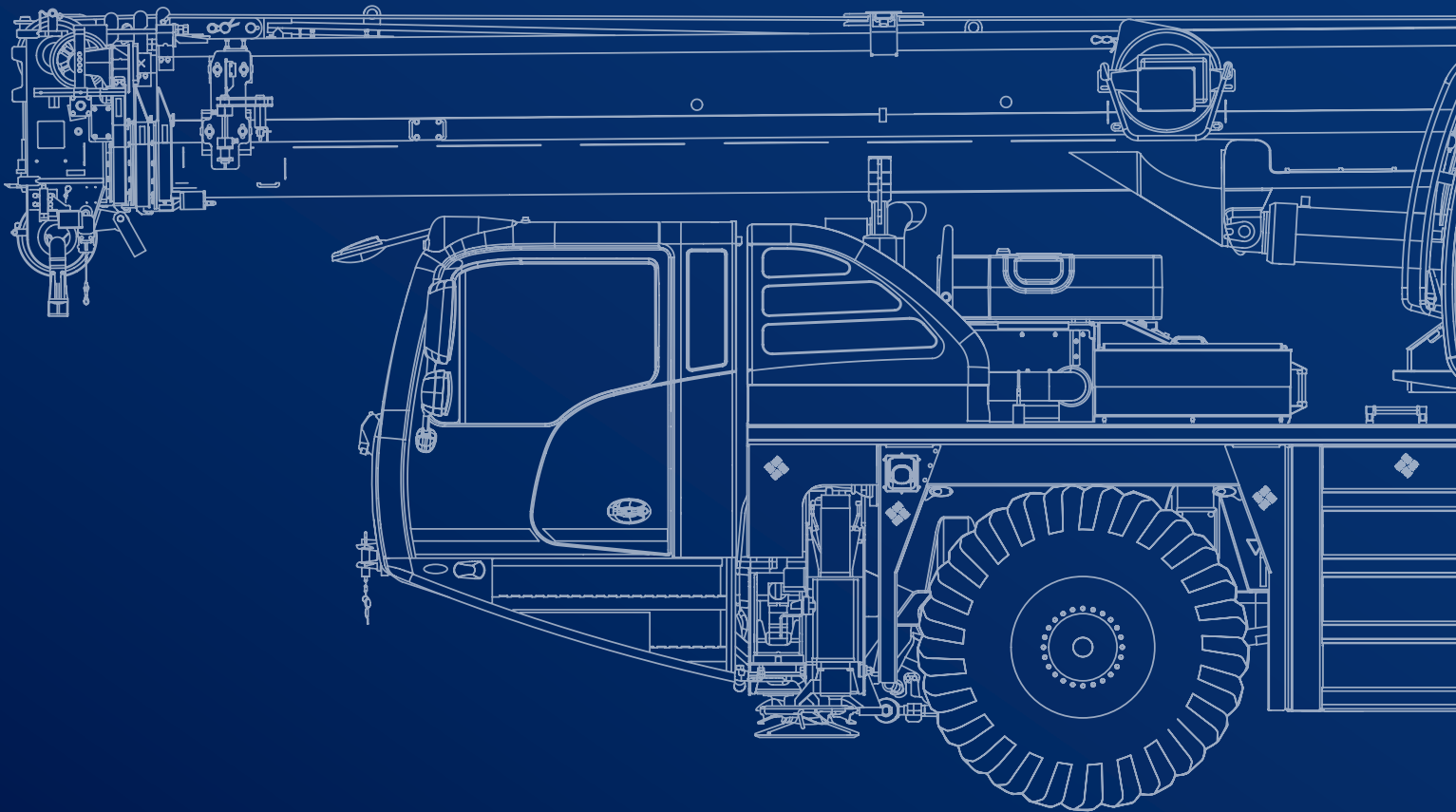

- e-PACK
- Suitable for alternative fuels





December 2024. Unless otherwise specified, all information in this brochure refers to a standard crane equipment, and it is intended as general information only. No liability is assumed. Errors reserved. Product specifications and prices are subject to changes without notice. The photographs and/or drawings in this brochure are for illustrative purposes only. For correct and safe crane operation, the original operating manual and lifting capacity charts are essential. Failure to follow the corresponding Operator's Manual when using our equipment or failure to otherwise act responsibly may result in property damage, serious injury or death. The sole warranty applicable with respect to our equipment is the standard warranty as per general terms and conditions of sales and service (ask your local Tadano dealer for details), and Tadano makes no other warranty, express or implied. All rights reserved. Any use of the trademarks, logos, brand names and model names used herein is prohibited.

© Tadano Ltd. 2024

Contents

General	5
Vehicle dimensions	6
Boom combinations	7
On-road and off-road driving	9
Axle loads	10
Speeds and gradeability	10
Steering	10
Transportation	11
Counterweight	12-13
Configurations	12
Jib	14
Operation	15
Main boom	17
Slewing	17
Hoist	17
Outrigger cylinders	17
Hook Blocks	17
HA: Main boom	18-22
HAV: Folding swing-away jib	24-27
MS: Runner	28-33
Notes to Lifting Capacity	34
Technical Description	35
Basic machine	36
Additional equipment	37

Key

	Counterweight		Working speeds
	Lifting capacities on outriggers · 360°		Slewing
	Radius		Max. line pull
	Main boom		Rope diameter
	Folding swing-away jib		Rope length
	Runner		Hook block
	Max. axle loads		Number of lines
	Mechanism		Possible load of hook block
	Tires		Weight of hook block
	Hook block		Distance head sheave axle – hook ground
	Hoist		Number of sheaves in hook block
	Travel speed		Max. outrigger load
	Gradeability		Length of stroke (support cylinders)
	Boom telescoping		Payload incl. rear storage box
	Boom elevation		

GENERAL TECHNICAL DATA

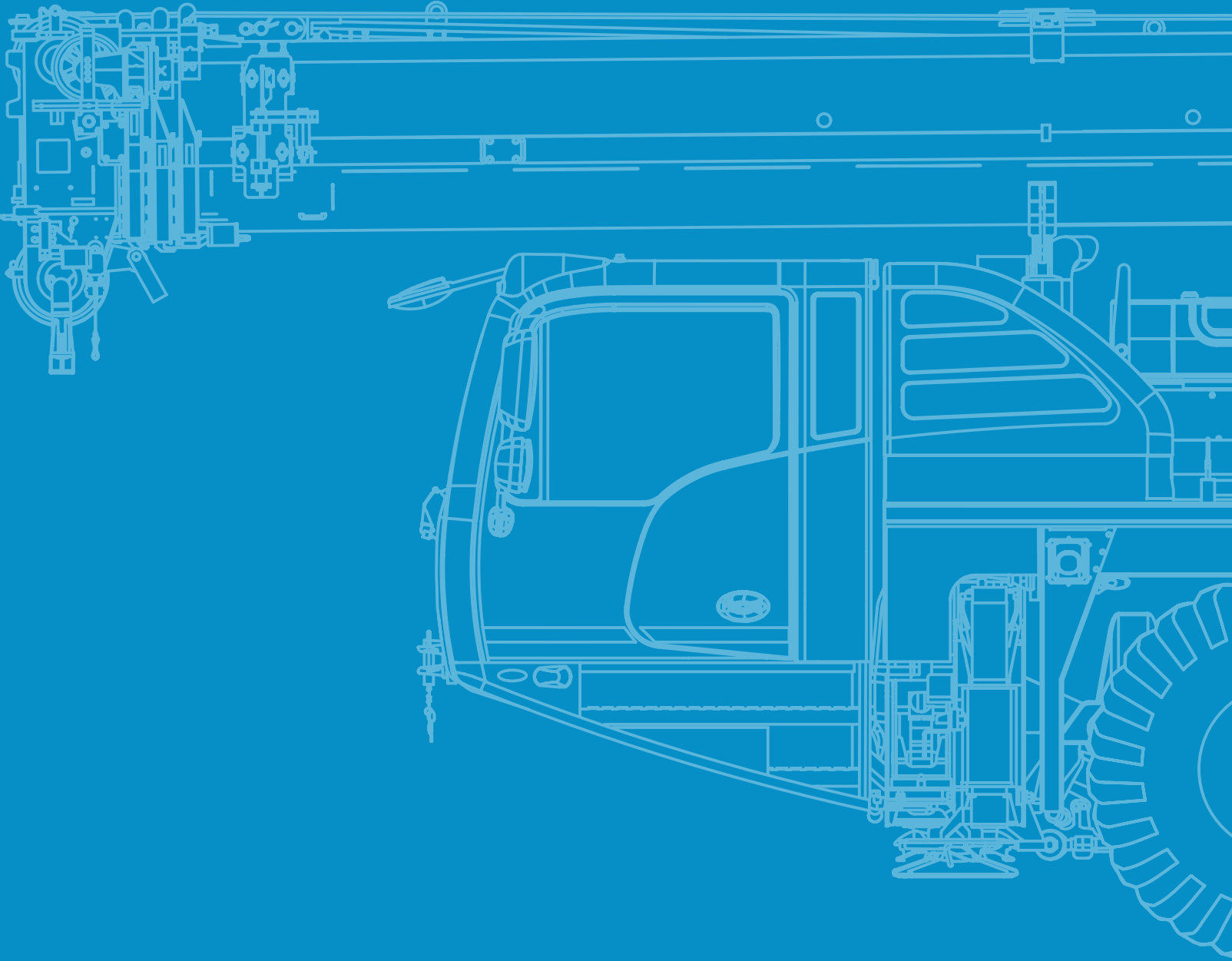

General

Vehicle dimensions

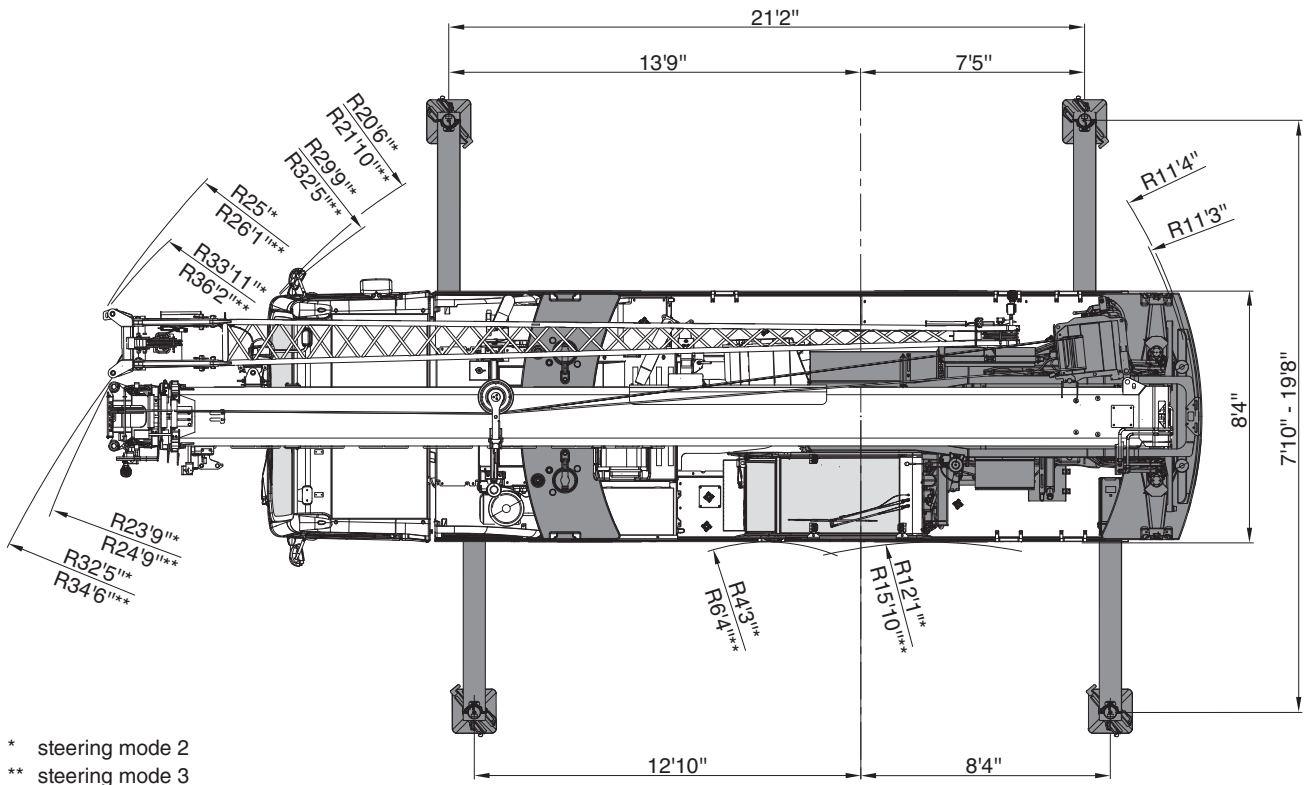
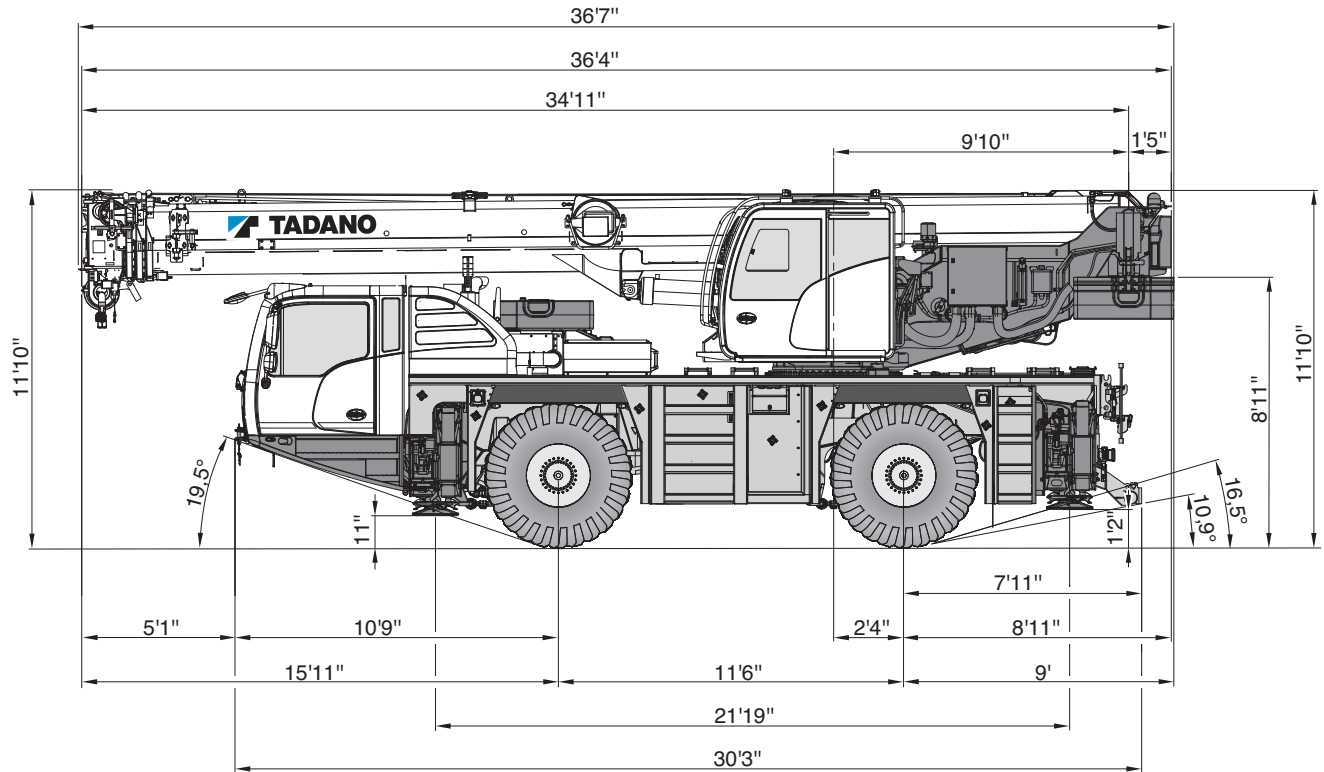

- * steering mode 2
- ** steering mode 3

General



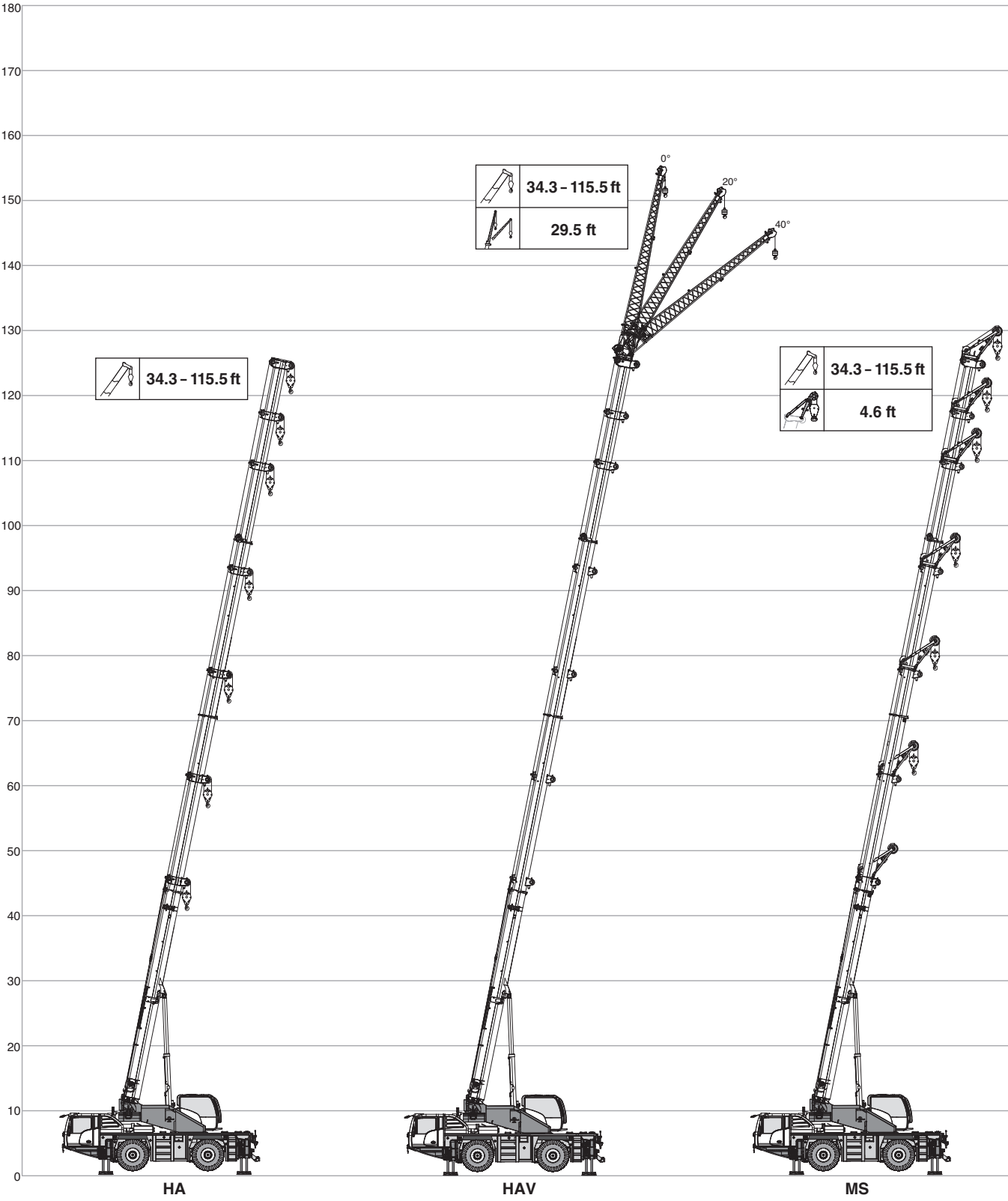

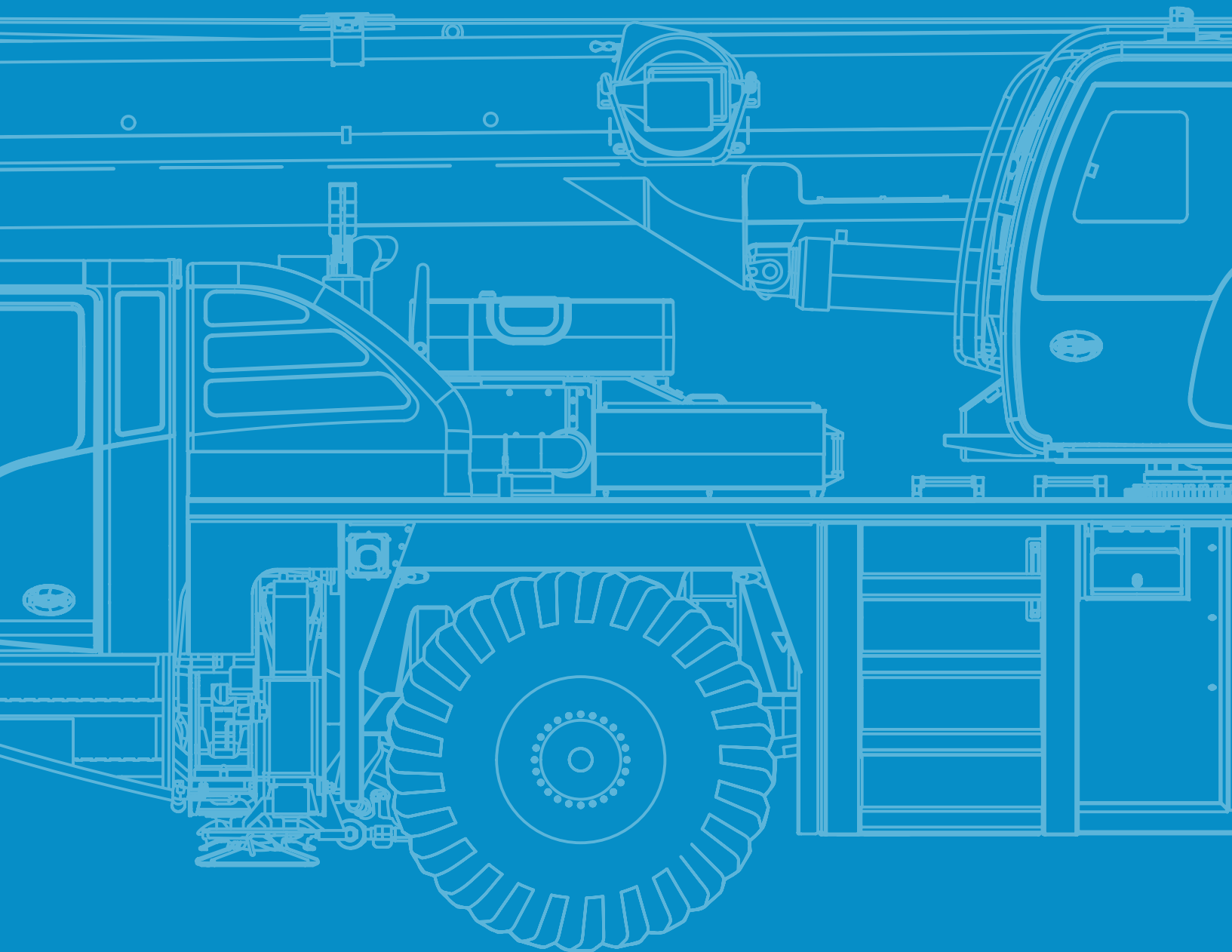

Boom combinations





TECHNICAL DATA FOR ON-ROAD AND OFF-ROAD DRIVING



On-road and off-road driving

Axle loads							
	Total						
< 26,450 lbs	< 52,900 lbs	4 x 4 x 4	445/95R25	55,100 lbs	2,400 lbs	–	330 lbs
< 28,650 lbs	< 57,300 lbs	4 x 4 x 4	445/95R25	55,100 lbs	4,000 lbs	29.5 ft	330 lbs
< 35,300 lbs	< 68,300 lbs	4 x 4 x 4	445/95R25	55,100 lbs	14,300 lbs	29.5 ft	550 lbs

Speeds and gradeability		
	445/95 R 25 16.00 R 25	525/80 R 25 20.50 R 25
	63 %	63 %
	52.8 mph ¹⁾	

¹⁾ Depending on tire type, size and country specific legislation

Steering	
	1 Highway
	2 All wheel steering
	3 Crab steer mode

TECHNICAL DATA FOR TRANSPORT

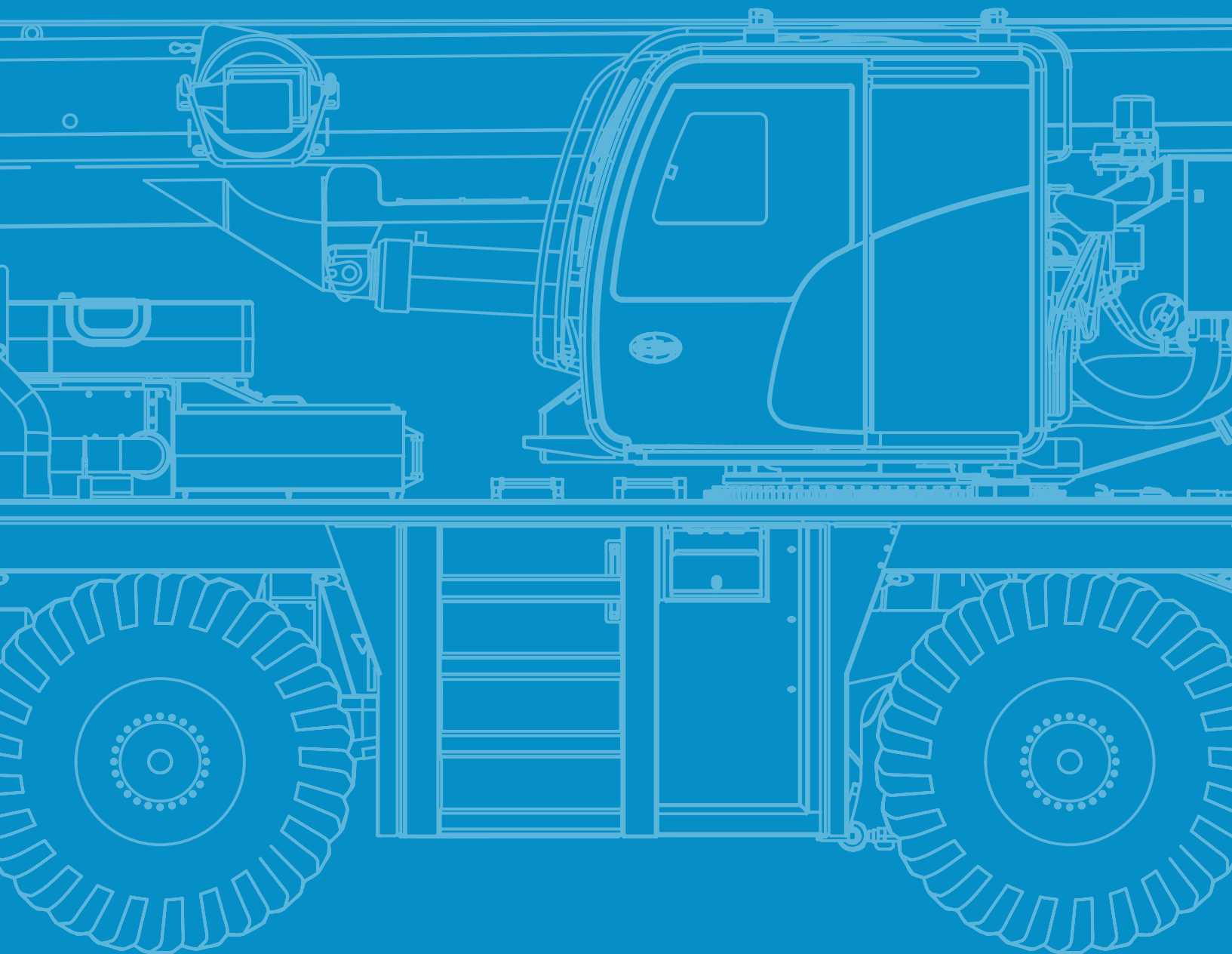

Transportation

Counterweight

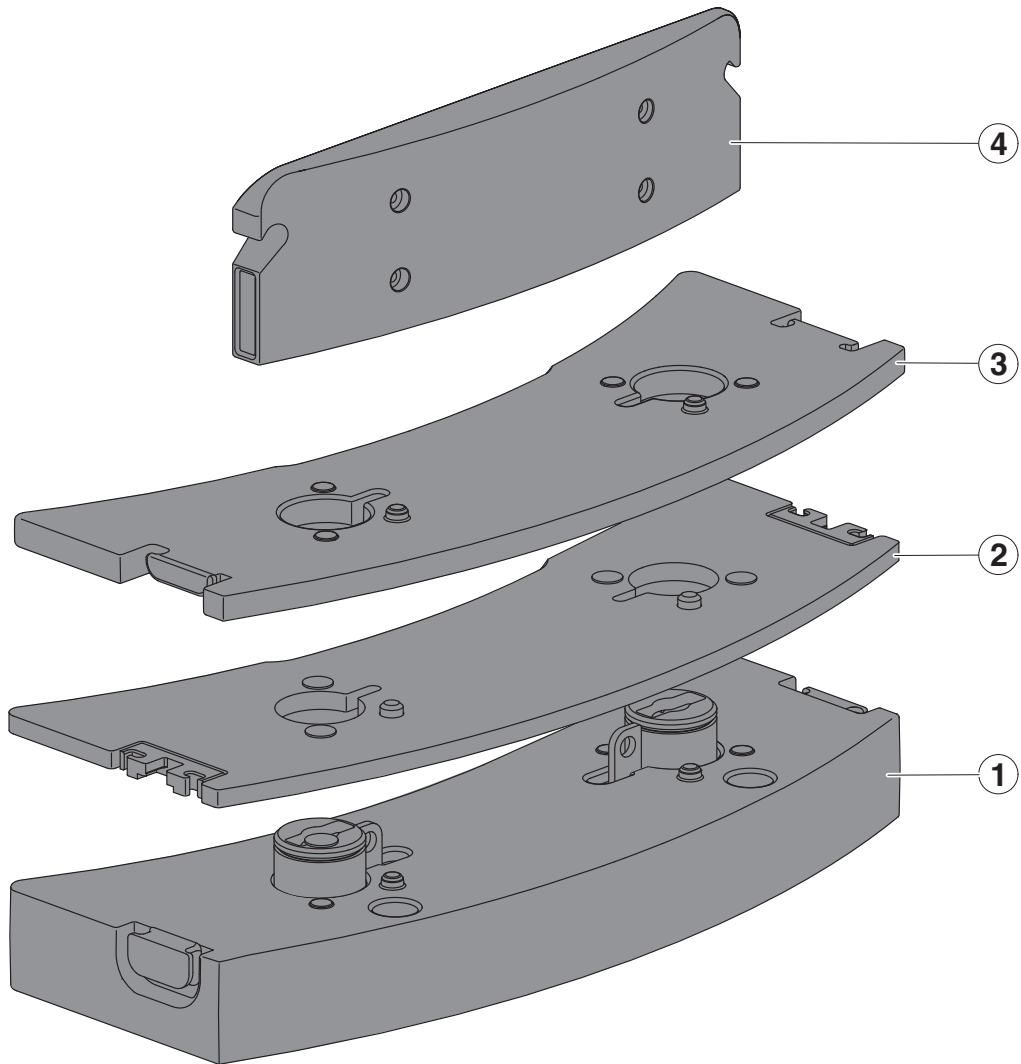

Configurations

	2,400 lbs	4,000 lbs	6,200 lbs	8,200 lbs	10,400 lbs	10,600 lbs	11,900 lbs	12,100 lbs	12,800 lbs	14,300 lbs
① 8,200 lbs				1	1	1	1	1	1	1
② 1,500 lbs		1	1				1	1		1
③ 2,200 lbs			1		1		1		1	1
④ 2,400 lbs	1	1	1			1		1	1	1

Transportation

Counterweight

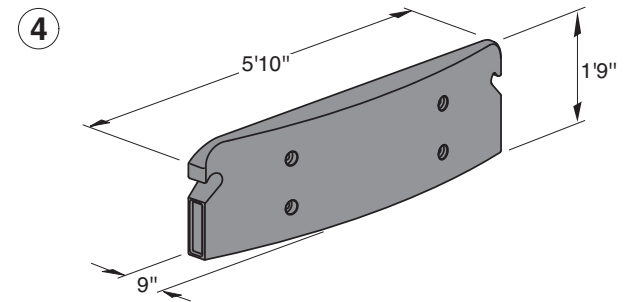
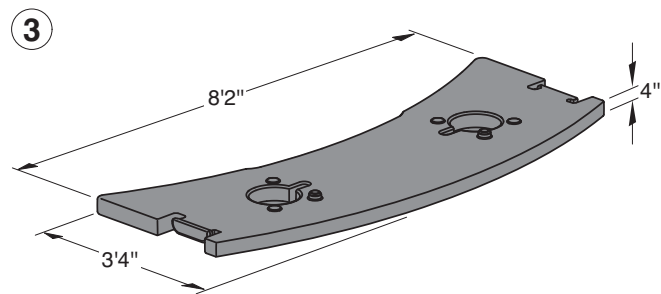
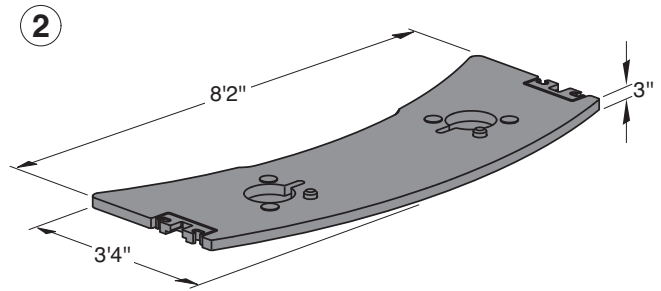
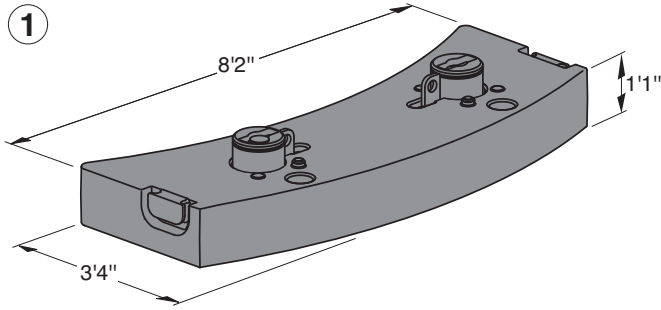

Transportation

Jib

HAV

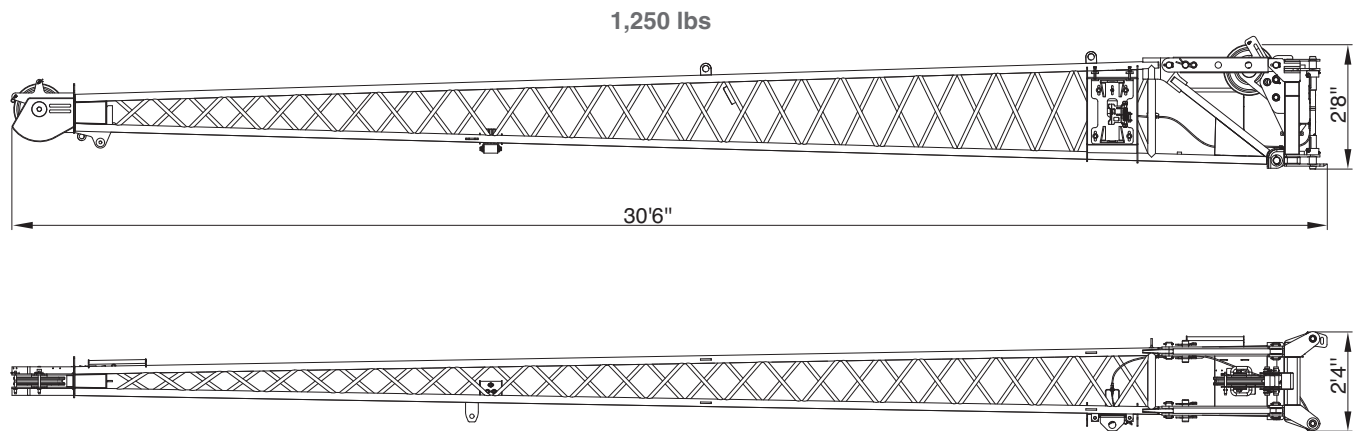

MS

700 lbs

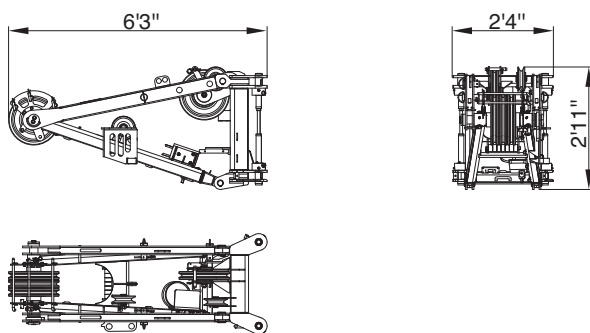

TECHNICAL DATA FOR OPERATION

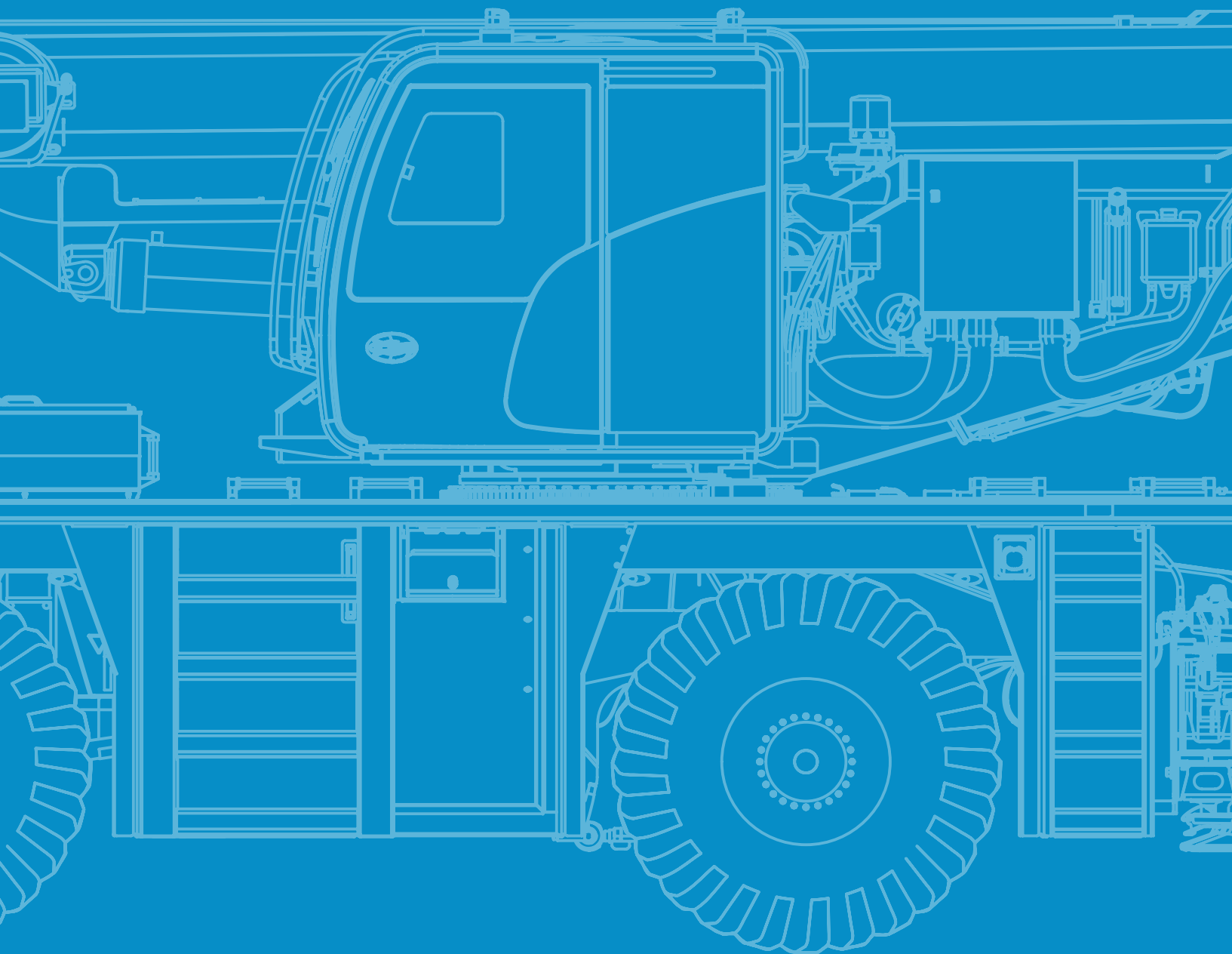

Operation

Main boom



approx. 88 s (34.3 - 115.5 ft)







approx. 28 s (-1° - 78°)

Slewing





2,00 min⁻¹

Hoist



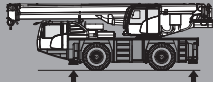

	 426.5 ft/min	 7,509 lbf	 0.55"	 492.1 ft
---	--	---	---	--

Outrigger cylinders

		
	55,100 lbs	72,700 lbs
	23.6"	23.6"

Hook Blocks



	 lbs			 lbs
8,800 lbs	7,400 lbs	–	1	165 lbs
22,050 lbs	21,900 lbs	1	3	330 lbs
55,100 lbs	50,100 lbs	3	7	440 lbs
88,200 lbs	77,200 lbs	5	11	620 lbs
110,200 lbs	80,000 lbs	7	13	1,000 lbs

Operation

14,300 lbs		19.7 ft x 21.3 ft											360°		ASME B30.5	
ft		34.3 ft*	34.3 ft	42.4 ft	50.5 ft	58.6 ft	66.8 ft	74.9 ft	83.0 ft	91.1 ft	99.2 ft	107.4 ft	115.5 ft	ft		
ft		1,000 lbs												ft		
8.2	80.0**	-	-	-	-	-	-	-	-	-	-	-	-	8.2	8.2	
9.8	80.0**	71.2	44.0	44.0	44.0	44.0	44.0	38.5	-	-	-	-	-	9.8	9.8	
11.5	77.6	64.3	44.0	44.0	44.0	44.0	44.0	38.5	33.2	-	-	-	-	11.5	11.5	
13.1	67.4	58.6	44.0	44.0	44.0	44.0	44.0	38.5	33.2	-	-	-	-	13.1	13.1	
14.8	59.3	53.3	44.0	44.0	44.0	44.0	44.0	38.5	33.2	27.7	-	-	-	14.8	14.8	
16.4	52.9	48.2	44.0	44.0	44.0	44.0	44.0	38.5	33.2	27.7	22.7	-	-	16.4	16.4	
19.7	43.2	40.3	40.5	40.7	41.0	40.3	38.5	30.6	27.7	27.7	22.7	19.6	-	19.7	19.7	
23.0	35.9	34.3	34.6	34.8	34.3	33.0	32.1	28.2	26.2	22.7	19.6	-	-	23.0	23.0	
26.2	-	-	28.4	28.6	28.6	27.9	27.1	26.0	24.2	21.6	19.6	16.7	-	26.2	26.2	
29.5	-	-	23.5	23.5	23.8	23.8	23.3	22.7	22.2	20.0	18.2	16.7	-	29.5	29.5	
32.8	-	-	-	20.0	20.0	20.0	20.2	19.8	19.4	18.7	17.1	15.8	-	32.8	32.8	
36.1	-	-	-	17.1	17.1	17.4	17.4	17.4	17.1	16.7	16.0	14.9	-	36.1	36.1	
39.4	-	-	-	14.9	14.9	15.2	15.2	15.2	15.2	14.9	14.7	14.1	-	39.4	39.4	
45.9	-	-	-	-	11.6	11.9	11.9	11.9	11.9	11.9	11.9	11.6	-	45.9	45.9	
52.5	-	-	-	-	-	9.4	9.4	9.4	9.4	9.4	9.7	9.7	-	52.5	52.5	
59.1	-	-	-	-	-	-	7.7	7.7	7.7	7.7	7.7	7.9	-	59.1	59.1	
65.6	-	-	-	-	-	-	-	6.3	6.3	6.3	6.3	6.3	-	65.6	65.6	
72.2	-	-	-	-	-	-	-	5.2	5.2	5.2	5.2	5.2	-	72.2	72.2	
78.7	-	-	-	-	-	-	-	-	4.4	4.4	4.4	4.4	-	78.7	78.7	
85.3	-	-	-	-	-	-	-	-	-	3.7	3.7	3.7	-	85.3	85.3	
91.9	-	-	-	-	-	-	-	-	-	-	3.0	3.0	-	91.9	91.9	
98.4	-	-	-	-	-	-	-	-	-	-	-	2.4	-	98.4	98.4	
105.0	-	-	-	-	-	-	-	-	-	-	-	1.9	-	105.0	105.0	
1)	22.0	22.0	16.9	13.6	10.5	8.1	6.3	5.0	4.1	3.3	2.6	1.9	-	1)	1)	

1) Capacities with horizontal boom

* over rear

** Max. crane capacity – with additional special equipment

Operation

HA

4,000 lbs		19.7 ft x 21.3 ft		360° / Max.*								ASME B30.5	
ft	360°	Max.	360°	Max.	360°	Max.	360°	Max.	360°	Max.	360°	Max.	ft
	34.3 ft	34.3 ft	42.4 ft	42.4 ft	50.5 ft	50.5 ft	58.6 ft	58.6 ft	66.8 ft	66.8 ft	74.9 ft	74.9 ft	
1,000 lbs													
9.8	69.6	69.6	44.0	44.0	44.0	44.0	44.0	44.0	44.0	44.0	38.5	38.5	9.8
11.5	62.3	62.8	44.0	44.0	44.0	44.0	44.0	44.0	44.0	44.0	38.5	38.5	11.5
13.1	55.3	57.0	44.0	44.0	44.0	44.0	44.0	44.0	44.0	44.0	38.5	38.5	13.1
14.8	49.3	51.3	44.0	44.0	44.0	44.0	44.0	44.0	44.0	44.0	38.5	38.5	14.8
16.4	44.5	45.6	44.0	44.0	42.3	44.0	40.1	44.0	38.1	44.0	36.5	38.5	16.4
19.7	34.6	37.2	34.1	37.6	32.6	37.9	31.3	37.9	29.9	38.1	28.8	38.1	19.7
23.0	26.2	31.3	26.6	31.5	26.2	31.7	25.3	31.9	24.4	31.9	23.5	32.1	23.0
26.2	-	-	21.1	27.1	21.1	27.3	20.9	27.3	20.2	27.3	19.8	27.1	26.2
29.5	-	-	17.1	23.5	17.4	23.5	17.4	23.8	17.1	23.8	16.7	23.3	29.5
32.8	-	-	-	-	14.5	20.0	14.5	20.0	14.7	20.0	14.5	20.2	32.8
36.1	-	-	-	-	12.3	17.1	12.3	17.1	12.3	17.4	12.5	17.4	36.1
39.4	-	-	-	-	10.3	14.9	10.5	14.9	10.5	15.2	10.5	15.2	39.4
45.9	-	-	-	-	-	-	7.7	11.6	7.7	11.9	7.9	11.9	45.9
52.5	-	-	-	-	-	-	-	-	5.9	9.4	5.9	9.4	52.5
59.1	-	-	-	-	-	-	-	-	-	-	4.6	7.7	59.1
1)	22.0	22.0	14.5	16.9	9.7	13.6	6.8	10.5	5.0	8.1	3.7	6.3	1)

ft	360°	Max.	360°	Max.	360°	Max.	360°	Max.	360°	Max.	360°	Max.	ft
	83.0 ft	83.0 ft	91.1 ft	91.1 ft	99.2 ft	99.2 ft	107.4 ft	107.4 ft	115.5 ft	115.5 ft			
1,000 lbs													
11.5	33.2	33.2	-	-	-	-	-	-	-	-	-	-	11.5
13.1	33.2	33.2	-	-	-	-	-	-	-	-	-	-	13.1
14.8	33.2	33.2	27.7	27.7	-	-	-	-	-	-	-	-	14.8
16.4	33.2	33.2	27.7	27.7	22.7	22.7	-	-	-	-	-	-	16.4
19.7	27.7	30.6	26.8	27.7	22.7	22.7	19.6	19.6	-	-	-	-	19.7
23.0	22.9	28.2	22.0	26.2	21.3	22.7	19.6	19.6	-	-	-	-	23.0
26.2	19.1	26.0	18.7	24.2	18.0	21.6	17.6	19.6	16.7	16.7	-	-	26.2
29.5	16.3	22.7	16.0	22.2	15.6	20.0	15.2	18.2	14.7	16.7	16.7	-	29.5
32.8	14.1	19.8	13.6	19.4	13.4	18.7	13.0	17.1	12.7	15.8	15.8	-	32.8
36.1	12.1	17.4	11.9	17.1	11.6	16.7	11.4	16.0	11.0	14.9	14.9	-	36.1
39.4	10.5	15.2	10.3	15.2	10.1	14.9	9.9	14.7	9.7	14.1	14.1	-	39.4
45.9	7.9	11.9	7.9	11.9	7.9	11.9	7.7	11.9	7.7	11.6	11.6	-	45.9
52.5	5.9	9.4	6.1	9.4	6.1	9.4	6.1	9.7	5.9	9.7	9.7	-	52.5
59.1	4.6	7.7	4.6	7.7	4.6	7.7	4.6	7.7	4.6	7.9	7.9	-	59.1
65.6	3.5	6.3	3.5	6.3	3.5	6.3	3.5	6.3	3.7	6.3	6.3	-	65.6
72.2	2.6	5.2	2.6	5.2	2.6	5.2	2.8	5.2	2.8	5.2	5.2	-	72.2
78.7	-	-	1.9	4.4	1.9	4.4	1.9	4.4	2.2	4.4	4.4	-	78.7
85.3	-	-	-	-	1.5	3.7	1.5	3.7	1.5	3.7	3.7	-	85.3
91.9	-	-	-	-	-	-	1.1	3.0	1.1	3.0	3.0	-	91.9
98.4	-	-	-	-	-	-	-	-	-	2.4	2.4	-	98.4
105.0	-	-	-	-	-	-	-	-	-	1.9	1.9	-	105.0
1)	2.6	5.0	1.9	4.1	1.3	3.3	-	2.6	-	1.9	-	-	1)

1) Capacities with horizontal boom

* Max. values are valid only for specific superstructure positions

Operation

2,400 lbs		19.7 ft x 21.3 ft		360° / Max.*								ASME B30.5		
ft	360° 34.3 ft	Max. 34.3 ft	360° 42.4 ft	Max. 42.4 ft	360° 50.5 ft	Max. 50.5 ft	360° 58.6 ft	Max. 58.6 ft	360° 66.8 ft	Max. 66.8 ft	360° 74.9 ft	Max. 74.9 ft	ft	
1,000 lbs														
9.8	69.4	69.4	44.0	44.0	44.0	44.0	44.0	44.0	44.0	44.0	44.0	38.5	38.5	9.8
11.5	61.7	62.6	44.0	44.0	44.0	44.0	44.0	44.0	44.0	44.0	44.0	38.5	38.5	11.5
13.1	54.6	56.8	44.0	44.0	44.0	44.0	44.0	44.0	44.0	44.0	44.0	38.5	38.5	13.1
14.8	48.7	50.4	44.0	44.0	44.0	44.0	44.0	44.0	41.8	44.0	38.5	38.5	14.8	
16.4	43.8	44.9	42.5	44.0	40.1	44.0	38.1	44.0	36.3	44.0	34.6	38.5	16.4	
19.7	32.8	36.5	32.4	37.0	30.8	37.2	29.5	37.4	28.4	37.4	27.3	37.4	19.7	
23.0	24.6	30.8	25.1	31.0	24.9	31.3	24.0	31.3	23.1	31.5	22.2	31.5	23.0	
26.2	-	-	19.8	26.6	20.0	26.8	19.8	26.8	19.1	26.8	18.7	27.1	26.2	
29.5	-	-	16.3	23.1	16.5	23.5	16.5	23.3	16.3	23.5	15.6	23.3	29.5	
32.8	-	-	-	-	13.6	20.0	13.6	20.0	13.6	20.0	13.4	20.2	32.8	
36.1	-	-	-	-	11.2	17.1	11.4	17.1	11.4	17.4	11.4	17.4	36.1	
39.4	-	-	-	-	9.4	14.9	9.7	14.9	9.7	15.2	9.9	15.2	39.4	
45.9	-	-	-	-	-	7.0	11.6	7.0	11.9	7.2	11.9	7.2	45.9	
52.5	-	-	-	-	-	-	-	-	5.2	9.4	5.2	9.4	52.5	
59.1	-	-	-	-	-	-	-	-	-	-	3.9	7.7	59.1	
1)	22.0	22.0	13.6	16.9	9.0	13.6	6.1	10.5	4.4	8.1	3.3	6.3	1)	

ft	360° 83.0 ft	Max. 83.0 ft	360° 91.1 ft	Max. 91.1 ft	360° 99.2 ft	Max. 99.2 ft	360° 107.4 ft	Max. 107.4 ft	360° 115.5 ft	Max. 115.5 ft	ft
1,000 lbs											
11.5	33.2	33.2	-	-	-	-	-	-	-	-	11.5
13.1	33.2	33.2	-	-	-	-	-	-	-	-	13.1
14.8	33.2	33.2	27.7	27.7	-	-	-	-	-	-	14.8
16.4	33.0	33.2	27.7	27.7	22.7	22.7	-	-	-	-	16.4
19.7	26.4	30.6	25.3	27.7	22.7	22.7	19.6	19.6	-	-	19.7
23.0	21.6	28.2	20.9	26.2	20.2	22.7	19.6	19.6	-	-	23.0
26.2	18.0	26.0	17.6	24.2	17.1	21.6	16.7	19.6	16.0	16.7	26.2
29.5	15.2	22.7	14.9	22.2	14.5	20.0	14.1	18.2	13.6	16.7	29.5
32.8	13.0	19.8	12.7	19.4	12.3	18.7	12.1	17.1	11.9	15.8	32.8
36.1	11.2	17.4	11.0	17.1	10.8	16.7	10.5	16.0	10.3	14.9	36.1
39.4	9.7	15.2	9.4	15.2	9.2	14.9	9.2	14.7	9.0	14.1	39.4
45.9	7.2	11.9	7.2	11.9	7.2	11.9	7.0	11.9	7.0	11.6	45.9
52.5	5.5	9.4	5.5	9.4	5.5	9.4	5.5	9.7	5.5	9.7	52.5
59.1	4.1	7.7	4.1	7.7	4.1	7.7	4.1	7.7	4.1	7.9	59.1
65.6	3.0	6.3	3.0	6.3	3.0	6.3	3.3	6.3	3.3	6.3	65.6
72.2	2.4	5.2	2.4	5.2	2.4	5.2	2.4	5.2	2.4	5.2	72.2
78.7	-	-	1.7	4.4	1.7	4.4	1.7	4.4	1.7	4.4	78.7
85.3	-	-	-	-	1.1	3.7	1.1	3.7	1.1	3.7	85.3
91.9	-	-	-	-	-	-	-	3.0	-	3.0	91.9
98.4	-	-	-	-	-	-	-	-	-	2.4	98.4
105.0	-	-	-	-	-	-	-	-	-	1.9	105.0
1)	2.2	5.0	1.5	4.1	-	3.3	-	2.6	-	1.9	1)

1) Capacities with horizontal boom

* Max. values are valid only for specific superstructure positions

Operation

HA

14,300 lbs		0°*		ASME B30.5
ft	34.3 ft	42.4 ft	50.5 ft	1,000 lbs
9.8	21.8	22.0	22.2	
11.5	19.6	19.8	20.0	
13.1	17.8	18.0	18.0	
14.8	16.0	16.5	16.5	
16.4	14.7	14.9	15.2	
19.7	12.5	12.7	12.7	
23.0	10.8	11.0	11.0	
26.2	-	9.4	9.4	
29.5	-	8.1	8.3	
32.8	-	-	7.2	
36.1	-	-	6.1	
39.4	-	-	5.2	
1)	9.9	7.2	4.8	

4,000 lbs		0°*		ASME B30.5
ft	34.3 ft	42.4 ft	50.5 ft	1,000 lbs
9.8	21.6	21.8	20.2	
11.5	19.4	18.7	17.4	
13.1	17.1	16.0	15.2	
14.8	14.9	14.1	13.4	
16.4	13.2	12.5	11.9	
19.7	10.3	9.9	9.4	
23.0	7.9	8.1	7.7	
26.2	-	6.3	6.3	
29.5	-	5.0	5.2	
32.8	-	-	4.1	
36.1	-	-	3.3	
39.4	-	-	2.6	
1)	7.0	4.1	2.4	

4,000 lbs		360°		ASME B30.5
ft	34.3 ft	42.4 ft	50.5 ft	1,000 lbs
11.5	11.6	10.8	10.1	
13.1	9.7	9.0	8.5	
14.8	8.1	7.7	7.2	
16.4	6.8	6.6	6.1	
19.7	5.0	4.8	4.6	
23.0	3.7	3.5	3.3	
26.2	-	2.6	2.4	
29.5	-	1.7	1.7	
32.8	-	-	1.1	
1)	3.3	1.3	-	

2,400 lbs		0°*		ASME B30.5
ft	34.3 ft	42.4 ft	50.5 ft	1,000 lbs
9.8	21.3	20.2	18.9	
11.5	18.5	17.4	16.3	
13.1	16.0	14.9	14.1	
14.8	13.8	13.2	12.3	
16.4	12.3	11.6	11.0	
19.7	9.4	9.2	8.8	
23.0	7.2	7.2	7.0	
26.2	-	5.9	5.7	
29.5	-	4.6	4.6	
32.8	-	-	3.7	
36.1	-	-	2.8	
39.4	-	-	2.2	
1)	6.3	3.7	1.9	

2,400 lbs		360°		ASME B30.5
ft	34.3 ft	42.4 ft	50.5 ft	1,000 lbs
11.5	10.1	9.4	8.8	
13.1	8.3	7.9	7.4	
14.8	7.0	6.6	6.1	
16.4	5.9	5.5	5.2	
19.7	4.1	3.9	3.7	
23.0	2.8	2.8	2.6	
26.2	-	1.9	1.7	
29.5	-	1.1	1.1	
1)	2.6	-	-	

1) Capacities with horizontal boom

* over rear

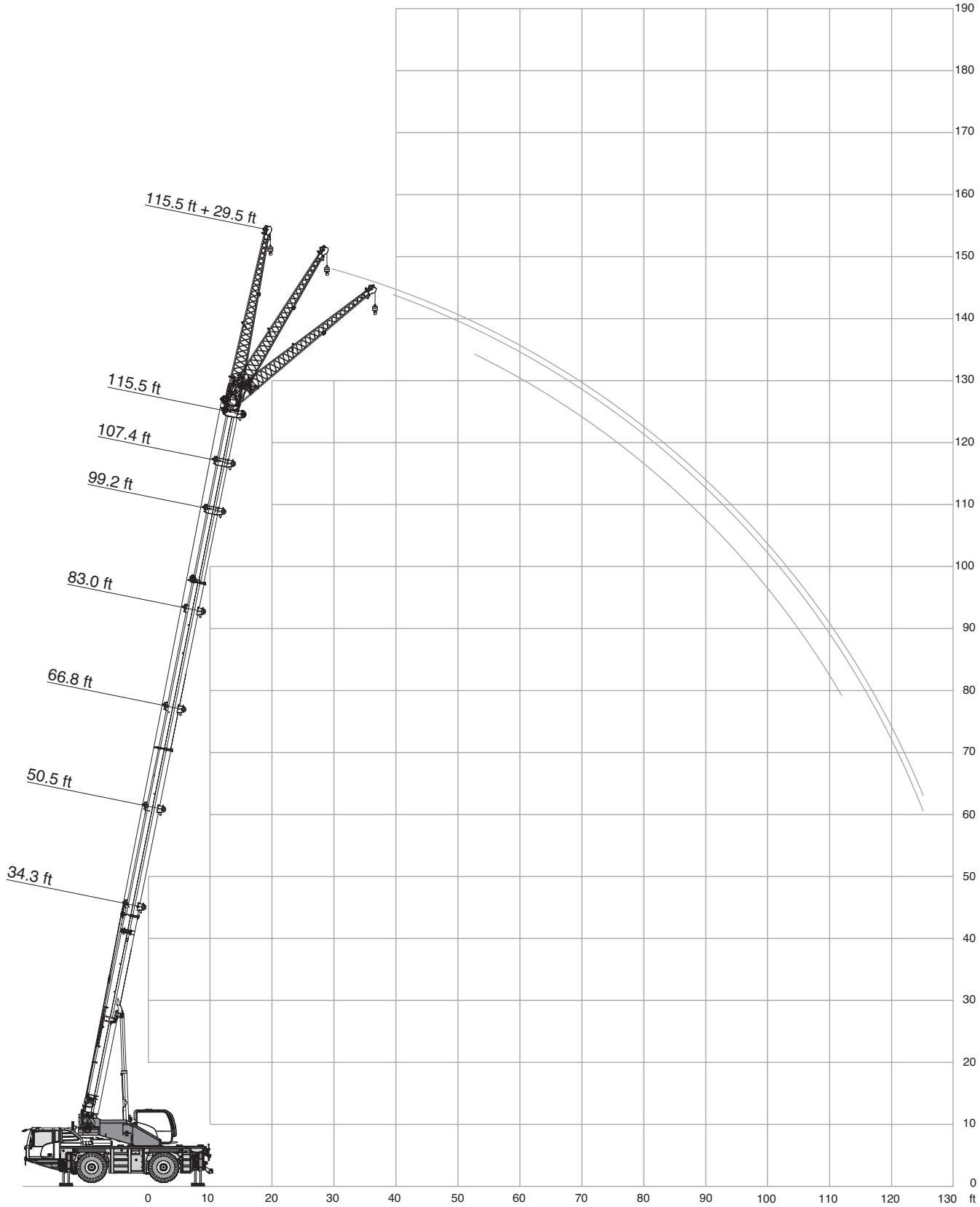

Operation

HAV

14,300 lbs		19.7 ft x 21.3 ft			29.5 ft			360°			ASME B30.5		
ft	34.3 ft			42.4 ft			50.5 ft			58.6 ft			ft
	0°	20°	40°	0°	20°	40°	0°	20°	40°	0°	20°	40°	
1,000 lbs													
13.1	14.3	-	-	-	-	-	-	-	-	-	-	-	13.1
14.8	14.3	-	-	-	-	-	-	-	-	-	-	-	14.8
16.4	14.3	14.1	-	14.3	-	-	14.3	-	-	-	-	-	16.4
19.7	14.3	13.2	-	14.3	-	-	14.3	-	-	14.3	-	-	19.7
23.0	14.3	12.3	10.1	14.3	-	-	14.3	-	-	14.3	-	-	23.0
26.2	14.1	11.6	9.7	14.3	12.1	-	14.3	12.3	-	14.3	-	-	26.2
29.5	13.2	11.0	9.2	14.1	11.4	-	14.3	11.9	-	14.3	12.1	-	29.5
32.8	12.5	10.3	9.0	13.4	11.0	9.2	14.1	11.4	-	14.3	11.6	-	32.8
36.1	11.6	9.9	8.8	12.7	10.5	9.0	13.4	11.0	9.2	13.6	11.2	9.4	36.1
39.4	11.0	9.4	8.5	12.1	10.1	8.8	12.7	10.5	9.0	13.2	10.8	9.2	39.4
45.9	9.7	8.8	8.3	10.8	9.2	8.3	11.6	9.7	8.5	12.1	10.1	8.8	45.9
52.5	8.8	8.5	-	9.9	8.8	8.3	10.8	9.2	8.3	10.5	9.7	8.5	52.5
59.1	-	-	-	9.0	8.3	-	9.0	8.8	8.3	8.8	9.0	8.3	59.1
65.6	-	-	-	-	-	-	7.4	7.7	-	7.2	7.7	7.7	65.6
72.2	-	-	-	-	-	-	-	-	-	6.1	6.3	-	72.2
78.7	-	-	-	-	-	-	-	-	-	5.2	-	-	78.7

ft	66.8 ft			74.9 ft			83.0 ft			91.1 ft			ft
	0°	20°	40°	0°	20°	40°	0°	20°	40°	0°	20°	40°	
1,000 lbs													
19.7	14.3	-	-	-	-	-	-	-	-	-	-	-	19.7
23.0	14.3	-	-	14.3	-	-	-	-	-	-	-	-	23.0
26.2	14.3	-	-	14.3	-	-	13.4	-	-	-	-	-	26.2
29.5	14.3	12.1	-	14.3	-	-	13.4	-	-	11.9	-	-	29.5
32.8	14.3	11.6	-	14.3	11.6	-	13.4	-	-	11.9	-	-	32.8
36.1	14.1	11.2	-	14.1	11.2	-	13.4	11.2	-	11.9	11.0	-	36.1
39.4	13.4	11.0	9.2	13.4	11.0	9.4	13.4	10.8	-	11.9	10.8	-	39.4
45.9	12.3	10.3	9.0	12.5	10.3	9.0	12.5	10.3	9.2	11.9	10.3	9.0	45.9
52.5	10.5	9.7	8.5	10.3	9.9	8.8	10.3	9.9	8.8	10.1	9.9	8.8	52.5
59.1	8.5	9.0	8.3	8.5	9.0	8.5	8.3	9.0	8.5	8.3	8.8	8.5	59.1
65.6	7.2	7.4	7.7	7.0	7.4	7.7	7.0	7.4	7.7	6.8	7.2	7.7	65.6
72.2	6.1	6.3	6.3	5.9	6.1	6.3	5.9	6.1	6.3	5.7	6.1	6.3	72.2
78.7	5.0	5.2	-	5.0	5.2	5.2	4.8	5.2	5.2	4.8	5.0	5.2	78.7
85.3	4.4	-	-	4.1	4.4	-	4.1	4.4	4.4	3.9	4.4	4.4	85.3
91.9	-	-	-	3.7	3.7	-	3.5	3.7	-	3.5	3.5	3.7	91.9
98.4	-	-	-	-	-	-	3.0	3.0	-	2.8	3.0	-	98.4
105.0	-	-	-	-	-	-	-	-	-	2.4	2.4	-	105.0

ft	99.2 ft			107.4 ft			115.5 ft			ft
	0°	20°	40°	0°	20°	40°	0°	20°	40°	
1,000 lbs										
29.5	11.2	-	-	9.7	-	-	8.8	-	-	29.5
32.8	11.2	-	-	9.7	-	-	8.8	-	-	32.8
36.1	11.2	-	-	9.7	-	-	8.8	-	-	36.1
39.4	11.2	10.5	-	9.7	9.7	-	8.8	8.8	-	39.4
45.9	11.2	10.1	-	9.7	9.7	8.8	8.8	8.8	-	45.9
52.5	9.9	9.7	8.8	9.4	9.2	8.5	8.8	8.8	8.3	52.5
59.1	8.1	8.8	8.5	8.1	8.5	8.3	7.9	8.3	7.9	59.1
65.6	6.8	7.2	7.7	6.6	7.2	7.7	6.6	7.2	7.4	65.6
72.2	5.7	6.1	6.3	5.5	5.9	6.3	5.5	5.9	6.3	72.2
78.7	4.6	5.0	5.2	4.6	5.0	5.2	4.6	5.0	5.2	78.7
85.3	3.9	4.1	4.4	3.9	4.1	4.4	3.7	4.1	4.4	85.3
91.9	3.3	3.5	3.7	3.3	3.5	3.7	3.0	3.5	3.7	91.9
98.4	2.8	3.0	3.0	2.6	2.8	3.0	2.6	2.8	3.0	98.4
105.0	2.2	2.4	-	2.2	2.4	2.4	2.2	2.4	2.4	105.0
111.5	1.9	1.9	-	1.7	1.9	-	1.7	1.9	1.9	111.5
118.1	1.5	-	-	1.5	1.5	-	1.3	1.5	-	118.1
124.7	-	-	-	1.1	-	-	1.1	1.1	-	124.7

Operation

HAV

4,000 lbs		19.7 ft x 21.3 ft			29.5 ft			360°			ASME B30.5		
ft	34.3 ft			42.4 ft			50.5 ft			58.6 ft			ft
	0°	20°	40°	0°	20°	40°	0°	20°	40°	0°	20°	40°	
1,000 lbs													
13.1	14.3	-	-	-	-	-	-	-	-	-	-	-	13.1
14.8	14.3	-	-	-	-	-	-	-	-	-	-	-	14.8
16.4	14.3	14.1	-	14.3	-	-	14.3	-	-	-	-	-	16.4
19.7	14.3	13.2	-	14.3	-	-	14.3	-	-	14.3	-	-	19.7
23.0	14.3	12.3	10.1	14.3	-	-	14.3	-	-	14.3	-	-	23.0
26.2	14.1	11.6	9.7	14.3	12.1	-	14.3	12.3	-	14.3	-	-	26.2
29.5	13.2	11.0	9.2	14.1	11.4	-	14.3	11.9	-	14.3	12.1	-	29.5
32.8	12.5	10.3	9.0	13.4	11.0	9.2	14.1	11.4	-	14.3	11.6	-	32.8
36.1	11.6	9.9	8.8	12.7	10.5	9.0	13.4	11.0	9.2	13.4	11.2	9.4	36.1
39.4	11.0	9.4	8.5	12.1	10.1	8.8	12.3	10.5	9.0	11.9	10.8	9.2	39.4
45.9	9.7	8.8	8.3	9.7	9.2	8.3	9.4	9.7	8.5	9.2	9.9	8.8	45.9
52.5	7.9	8.1	-	7.7	7.9	8.1	7.4	7.9	8.1	7.2	7.7	8.1	52.5
59.1	-	-	-	6.1	6.3	-	5.9	6.1	6.3	5.7	6.1	6.3	59.1
65.6	-	-	-	-	-	-	4.8	5.0	-	4.6	4.8	5.0	65.6
72.2	-	-	-	-	-	-	-	-	-	3.7	3.9	-	72.2
78.7	-	-	-	-	-	-	-	-	-	3.0	-	-	78.7

ft	66.8 ft			74.9 ft			83.0 ft			91.1 ft			ft
	0°	20°	40°	0°	20°	40°	0°	20°	40°	0°	20°	40°	
1,000 lbs													
19.7	14.3	-	-	-	-	-	-	-	-	-	-	-	19.7
23.0	14.3	-	-	14.3	-	-	-	-	-	-	-	-	23.0
26.2	14.3	-	-	14.3	-	-	13.4	-	-	-	-	-	26.2
29.5	14.3	12.1	-	14.3	-	-	13.4	-	-	11.9	-	-	29.5
32.8	14.3	11.6	-	14.3	11.6	-	13.4	-	-	11.9	-	-	32.8
36.1	13.0	11.2	-	12.5	11.2	-	12.1	11.2	-	11.6	11.0	-	36.1
39.4	11.4	11.0	9.2	11.0	11.0	9.4	10.5	10.8	-	10.1	10.8	-	39.4
45.9	9.0	9.7	9.0	8.8	9.4	9.0	8.3	9.2	9.2	8.1	8.8	9.0	45.9
52.5	7.0	7.7	8.1	7.0	7.4	8.1	6.8	7.4	7.9	6.3	7.2	7.7	52.5
59.1	5.5	6.1	6.3	5.5	5.9	6.3	5.2	5.9	6.3	5.2	5.7	6.3	59.1
65.6	4.4	4.8	5.0	4.4	4.8	5.0	4.1	4.6	5.0	4.1	4.6	5.0	65.6
72.2	3.5	3.9	3.9	3.5	3.7	3.9	3.3	3.7	3.9	3.3	3.7	3.9	72.2
78.7	2.8	3.0	-	2.8	3.0	3.0	2.6	2.8	3.0	2.6	2.8	3.0	78.7
85.3	2.4	-	-	2.2	2.4	-	1.9	2.2	2.4	1.9	2.2	2.4	85.3
91.9	-	-	-	1.7	1.7	-	1.5	1.7	-	1.5	1.7	1.7	91.9
98.4	-	-	-	-	-	-	1.1	1.3	-	1.1	1.3	-	98.4

ft	99.2 ft			107.4 ft			115.5 ft			ft
	0°	20°	40°	0°	20°	40°	0°	20°	40°	
1,000 lbs										
29.5	11.2	-	-	9.7	-	-	8.8	-	-	29.5
32.8	11.2	-	-	9.7	-	-	8.8	-	-	32.8
36.1	11.2	-	-	9.7	-	-	8.8	-	-	36.1
39.4	9.9	10.5	-	9.7	9.7	-	8.8	8.8	-	39.4
45.9	7.7	8.5	-	7.4	8.3	8.8	7.2	8.1	-	45.9
52.5	6.1	7.0	7.4	5.9	6.8	7.4	5.7	6.6	7.2	52.5
59.1	5.0	5.7	6.1	4.8	5.5	5.9	4.6	5.2	5.7	59.1
65.6	3.9	4.6	5.0	3.9	4.4	4.8	3.7	4.1	4.6	65.6
72.2	3.0	3.5	3.9	3.0	3.5	3.9	3.0	3.5	3.7	72.2
78.7	2.4	2.8	3.0	2.4	2.8	3.0	2.2	2.6	3.0	78.7
85.3	1.9	2.2	2.4	1.7	2.2	2.4	1.7	1.9	2.4	85.3
91.9	1.3	1.5	1.7	1.3	1.5	1.7	1.3	1.5	1.7	91.9
98.4	-	1.1	1.3	-	1.1	1.3	-	1.1	1.3	98.4

Operation

HAV

2,400 lbs		19.7 ft x 21.3 ft			29.5 ft			360°			ASME B30.5		
ft	34.3 ft			42.4 ft			50.5 ft			58.6 ft			ft
	0°	20°	40°	0°	20°	40°	0°	20°	40°	0°	20°	40°	
1,000 lbs													
13.1	14.3	-	-	-	-	-	-	-	-	-	-	-	13.1
14.8	14.3	-	-	-	-	-	-	-	-	-	-	-	14.8
16.4	14.3	14.1	-	14.3	-	-	14.3	-	-	-	-	-	16.4
19.7	14.3	13.2	-	14.3	-	-	14.3	-	-	14.3	-	-	19.7
23.0	14.3	12.3	10.1	14.3	-	-	14.3	-	-	14.3	-	-	23.0
26.2	14.1	11.6	9.7	14.3	12.1	-	14.3	12.3	-	14.3	-	-	26.2
29.5	13.2	11.0	9.2	14.1	11.4	-	14.3	11.9	-	14.3	12.1	-	29.5
32.8	12.5	10.3	9.0	13.4	11.0	9.2	14.1	11.4	-	14.3	11.6	-	32.8
36.1	11.6	9.9	8.8	12.7	10.5	9.0	13.2	11.0	9.2	12.5	11.2	9.4	36.1
39.4	11.0	9.4	8.5	11.9	10.1	8.8	11.4	10.5	9.0	11.0	10.8	9.2	39.4
45.9	9.2	8.8	8.3	9.0	9.2	8.3	8.8	9.4	8.5	8.5	9.2	8.8	45.9
52.5	7.2	7.4	-	7.0	7.4	7.7	6.8	7.2	7.7	6.6	7.2	7.7	52.5
59.1	-	-	-	5.7	5.9	-	5.5	5.7	5.9	5.2	5.7	5.9	59.1
65.6	-	-	-	-	-	-	4.4	4.6	-	4.1	4.4	4.6	65.6
72.2	-	-	-	-	-	-	-	-	-	3.3	3.5	-	72.2
78.7	-	-	-	-	-	-	-	-	-	2.6	-	-	78.7

ft	66.8 ft			74.9 ft			83.0 ft			91.1 ft			ft
	0°	20°	40°	0°	20°	40°	0°	20°	40°	0°	20°	40°	
1,000 lbs													
19.7	14.3	-	-	-	-	-	-	-	-	-	-	-	19.7
23.0	14.3	-	-	14.3	-	-	-	-	-	-	-	-	23.0
26.2	14.3	-	-	14.3	-	-	13.4	-	-	-	-	-	26.2
29.5	14.3	12.1	-	14.3	-	-	13.4	-	-	11.9	-	-	29.5
32.8	13.8	11.6	-	13.2	11.6	-	12.7	-	-	11.9	-	-	32.8
36.1	12.1	11.2	-	11.6	11.2	-	11.2	11.2	-	10.8	11.0	-	36.1
39.4	10.5	11.0	9.2	10.1	11.0	9.4	9.9	10.8	-	9.4	10.5	-	39.4
45.9	8.3	9.0	9.0	7.9	8.8	9.0	7.7	8.5	9.2	7.4	8.1	9.0	45.9
52.5	6.6	7.0	7.4	6.3	7.0	7.4	6.1	6.8	7.4	5.9	6.6	7.2	52.5
59.1	5.0	5.5	5.9	5.0	5.5	5.9	4.8	5.5	5.9	4.6	5.2	5.7	59.1
65.6	3.9	4.4	4.6	3.9	4.4	4.6	3.7	4.1	4.6	3.7	4.1	4.6	65.6
72.2	3.3	3.5	3.5	3.0	3.3	3.5	2.8	3.3	3.5	2.8	3.3	3.5	72.2
78.7	2.6	2.6	-	2.4	2.6	2.8	2.2	2.6	2.8	2.2	2.6	2.8	78.7
85.3	1.9	-	-	1.7	1.9	-	1.7	1.9	1.9	1.5	1.9	1.9	85.3
91.9	-	-	-	1.3	1.5	-	1.3	1.5	-	1.1	1.3	1.5	91.9

ft	99.2 ft			107.4 ft			115.5 ft			ft
	0°	20°	40°	0°	20°	40°	0°	20°	40°	
1,000 lbs										
29.5	11.2	-	-	9.7	-	-	8.8	-	-	29.5
32.8	11.2	-	-	9.7	-	-	8.8	-	-	32.8
36.1	10.3	-	-	9.7	-	-	8.8	-	-	36.1
39.4	9.2	10.1	-	8.8	9.7	-	8.5	8.8	-	39.4
45.9	7.2	7.9	-	6.8	7.7	8.5	6.6	7.4	-	45.9
52.5	5.7	6.3	7.0	5.5	6.1	6.8	5.2	5.9	6.6	52.5
59.1	4.6	5.0	5.7	4.4	5.0	5.5	4.1	4.8	5.2	59.1
65.6	3.5	4.1	4.6	3.5	3.9	4.4	3.3	3.7	4.1	65.6
72.2	2.8	3.3	3.5	2.6	3.0	3.5	2.6	3.0	3.5	72.2
78.7	2.2	2.4	2.6	1.9	2.4	2.6	1.9	2.4	2.6	78.7
85.3	1.5	1.7	1.9	1.5	1.7	1.9	1.3	1.7	1.9	85.3
91.9	1.1	1.3	1.5	1.1	1.3	1.5	-	1.3	1.5	91.9
98.4	-	-	1.1	-	-	1.1	-	-	-	98.4

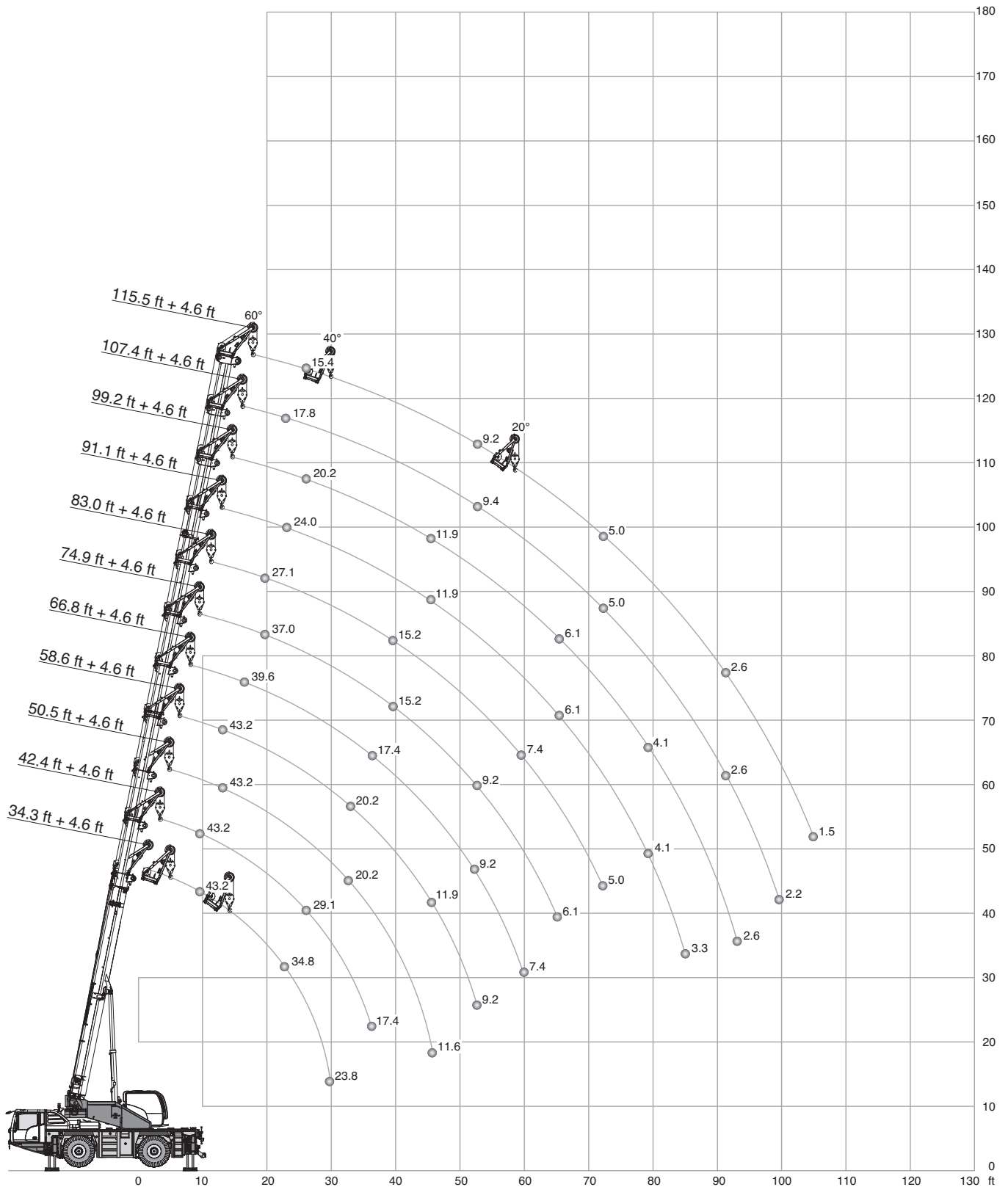

Operation

MS

14,300 lbs		19.7 ft x 21.3 ft		60°		360°		ASME B30.5				
ft	34.3 ft	42.4 ft	50.5 ft	58.6 ft	66.8 ft	74.9 ft	83.0 ft	91.1 ft	99.2 ft	107.4 ft	115.5 ft	ft
	1,000 lbs											
9.8	43.2	43.2	-	-	-	-	-	-	-	-	-	9.8
11.5	43.2	43.2	-	-	-	-	-	-	-	-	-	11.5
13.1	43.2	43.2	43.2	43.2	-	-	-	-	-	-	-	13.1
14.8	43.2	43.2	43.2	43.2	-	-	-	-	-	-	-	14.8
16.4	43.2	43.2	43.2	43.2	39.6	-	-	-	-	-	-	16.4
19.7	41.0	41.0	41.0	41.2	37.0	37.0	27.1	-	-	-	-	19.7
23.0	34.8	35.0	35.0	33.9	32.6	31.5	25.3	24.0	-	17.8	-	23.0
26.2	28.8	29.1	29.1	28.4	27.5	26.6	23.8	22.7	20.2	17.8	15.4	26.2
29.5	23.8	24.0	24.0	24.0	23.5	22.9	22.2	21.1	18.7	17.4	15.4	29.5
32.8	-	20.2	20.2	20.2	20.2	20.0	19.4	18.9	17.6	16.3	15.2	32.8
36.1	-	17.4	17.4	17.4	17.4	17.4	17.4	17.1	16.7	16.3	15.2	36.1
39.4	-	-	15.2	15.2	15.2	15.2	15.2	14.9	14.5	14.3	13.4	39.4
45.9	-	-	11.6	11.9	11.9	11.6	11.9	11.9	11.9	11.4	11.2	45.9
52.5	-	-	-	9.2	9.2	9.2	9.2	9.4	9.4	9.4	9.2	52.5
59.1	-	-	-	-	7.4	7.4	7.4	7.4	7.4	7.4	7.4	59.1
65.6	-	-	-	-	-	6.1	6.1	6.1	6.1	6.1	6.1	65.6
72.2	-	-	-	-	-	-	5.0	5.0	5.0	5.0	5.0	72.2
78.7	-	-	-	-	-	-	-	4.1	4.1	4.1	4.1	78.7
85.3	-	-	-	-	-	-	-	3.3	3.3	3.3	3.3	85.3
91.9	-	-	-	-	-	-	-	-	2.6	2.6	2.6	91.9
98.4	-	-	-	-	-	-	-	-	-	2.2	2.2	98.4
105.0	-	-	-	-	-	-	-	-	-	-	1.5	105.0
1)	18.5	14.5	11.6	8.8	6.8	5.2	4.1	3.3	2.4	1.7	1.3	1)

14,300 lbs		19.7 ft x 21.3 ft		40°		360°		ASME B30.5				
ft	34.3 ft	42.4 ft	50.5 ft	58.6 ft	66.8 ft	74.9 ft	83.0 ft	91.1 ft	99.2 ft	107.4 ft	115.5 ft	ft
	1,000 lbs											
9.8	43.2	43.2	-	-	-	-	-	-	-	-	-	9.8
11.5	43.2	43.2	-	-	-	-	-	-	-	-	-	11.5
13.1	43.2	43.2	43.2	-	-	-	-	-	-	-	-	13.1
14.8	43.2	43.2	43.2	-	-	-	-	-	-	-	-	14.8
16.4	43.2	43.2	43.2	43.2	-	-	-	-	-	-	-	16.4
19.7	40.7	40.7	40.7	40.7	39.2	-	-	-	-	-	-	19.7
23.0	34.6	34.8	34.8	33.5	32.1	31.0	-	-	-	-	-	23.0
26.2	28.8	28.8	28.8	28.2	27.1	26.2	24.4	-	-	-	-	26.2
29.5	23.8	23.8	23.8	23.8	23.3	22.7	22.0	21.3	-	-	-	29.5
32.8	-	20.0	20.0	20.0	20.0	19.8	19.1	18.7	-	-	-	32.8
36.1	-	17.4	17.4	17.4	17.4	17.1	17.1	16.9	16.5	16.3	-	36.1
39.4	-	-	14.9	14.9	14.9	14.9	14.9	14.9	14.7	14.3	14.1	39.4
45.9	-	-	11.6	11.6	11.6	11.6	11.6	11.6	11.6	11.4	11.2	45.9
52.5	-	-	-	9.2	9.2	9.2	9.2	9.2	9.2	9.2	9.2	52.5
59.1	-	-	-	-	7.4	7.4	7.4	7.4	7.4	7.4	7.4	59.1
65.6	-	-	-	-	-	6.1	5.9	5.9	6.1	6.1	5.9	65.6
72.2	-	-	-	-	-	-	5.0	4.8	5.0	4.8	4.8	72.2
78.7	-	-	-	-	-	-	-	3.9	3.9	3.9	3.9	78.7
85.3	-	-	-	-	-	-	-	3.3	3.3	3.3	3.3	85.3
91.9	-	-	-	-	-	-	-	-	2.6	2.6	2.6	91.9
98.4	-	-	-	-	-	-	-	-	-	2.2	2.2	98.4
105.0	-	-	-	-	-	-	-	-	-	-	1.5	105.0
111.5	-	-	-	-	-	-	-	-	-	-	1.3	111.5
1)	18.2	14.3	11.4	8.8	6.8	5.2	4.1	3.0	2.4	1.7	1.3	1)

Operation

MS

14,300 lbs													19.7 ft x 21.3 ft		20°		360°		ASME B30.5																	
ft													34.3 ft		42.4 ft		50.5 ft		58.6 ft		66.8 ft		74.9 ft		83.0 ft		91.1 ft		99.2 ft		107.4 ft		115.5 ft		ft	
ft													1,000 lbs													ft										
16.4	43.2	-	-	-	-	-	-	-	-	-	-	-	-	-	-	-	-	-	-	-	-	-	16.4													
19.7	40.3	-	-	-	-	-	-	-	-	-	-	-	-	-	-	-	-	-	-	-	-	-	19.7													
23.0	34.3	34.3	-	-	-	-	-	-	-	-	-	-	-	-	-	-	-	-	-	-	-	-	23.0													
26.2	28.6	28.6	-	-	-	-	-	-	-	-	-	-	-	-	-	-	-	-	-	-	-	-	26.2													
29.5	23.8	23.5	23.5	-	-	-	-	-	-	-	-	-	-	-	-	-	-	-	-	-	-	-	29.5													
32.8	-	20.0	20.0	19.8	-	-	-	-	-	-	-	-	-	-	-	-	-	-	-	-	-	-	32.8													
36.1	-	17.1	17.1	17.1	-	-	-	-	-	-	-	-	-	-	-	-	-	-	-	-	-	-	36.1													
39.4	-	-	14.9	14.9	14.9	-	-	-	-	-	-	-	-	-	-	-	-	-	-	-	-	-	39.4													
45.9	-	-	-	11.6	11.4	11.4	-	-	-	-	-	-	-	-	-	-	-	-	-	-	-	-	45.9													
52.5	-	-	-	9.2	9.2	9.0	9.0	9.0	-	-	-	-	-	-	-	-	-	-	-	-	-	-	52.5													
59.1	-	-	-	-	7.4	7.2	7.2	7.2	7.2	7.2	-	-	-	-	-	-	-	-	-	-	-	-	59.1													
65.6	-	-	-	-	-	5.9	5.9	5.9	5.9	5.9	5.9	-	-	-	-	-	-	-	-	-	-	-	65.6													
72.2	-	-	-	-	-	-	-	4.8	4.8	4.8	4.8	4.8	-	-	-	-	-	-	-	-	-	-	72.2													
78.7	-	-	-	-	-	-	-	-	-	3.9	3.9	3.9	3.9	-	-	-	-	-	-	-	-	-	78.7													
85.3	-	-	-	-	-	-	-	-	-	3.3	3.3	3.3	3.3	3.3	-	-	-	-	-	-	-	-	85.3													
91.9	-	-	-	-	-	-	-	-	-	-	2.6	2.6	2.6	2.6	2.6	-	-	-	-	-	-	-	91.9													
98.4	-	-	-	-	-	-	-	-	-	-	-	2.2	1.9	1.9	1.9	-	-	-	-	-	-	-	98.4													
105.0	-	-	-	-	-	-	-	-	-	-	-	-	1.5	1.5	1.5	1.5	-	-	-	-	-	-	105.0													
1)	18.2	14.3	11.6	8.8	6.8	5.2	4.1	3.3	2.4	1.7	1.3	1.3	1.3	1.3	1.3	1.3	1.3	1.3	1.3	1.3	1.3	1.3	1)													

4,000 lbs													19.7 ft x 21.3 ft		60°		360°		ASME B30.5																	
ft													34.3 ft		42.4 ft		50.5 ft		58.6 ft		66.8 ft		74.9 ft		83.0 ft		91.1 ft		99.2 ft		107.4 ft		115.5 ft		ft	
ft													1,000 lbs													ft										
9.8	43.2	43.2	-	-	-	-	-	-	-	-	-	-	-	-	-	-	-	-	-	-	-	-	9.8													
11.5	43.2	43.2	-	-	-	-	-	-	-	-	-	-	-	-	-	-	-	-	-	-	-	-	11.5													
13.1	43.2	43.2	43.2	43.2	-	-	-	-	-	-	-	-	-	-	-	-	-	-	-	-	-	-	13.1													
14.8	43.2	43.2	43.2	43.2	-	-	-	-	-	-	-	-	-	-	-	-	-	-	-	-	-	-	14.8													
16.4	43.2	43.2	41.6	39.4	37.4	-	-	-	-	-	-	-	-	-	-	-	-	-	-	-	-	-	16.4													
19.7	35.7	33.9	32.1	30.8	29.5	28.4	27.1	-	-	-	-	-	-	-	-	-	-	-	-	-	-	-	19.7													
23.0	27.1	27.1	26.0	24.9	24.0	23.1	22.4	21.8	-	17.8	-	-	-	-	-	-	-	-	-	-	-	-	23.0													
26.2	21.6	21.6	21.6	20.7	20.0	19.4	18.7	18.2	17.8	17.1	15.4	-	-	-	-	-	-	-	-	-	-	-	26.2													
29.5	17.6	17.6	17.8	17.6	16.9	16.5	16.0	15.6	15.2	14.7	14.3	12.3	-	-	-	-	-	-	-	-	-	-	29.5													
32.8	-	14.7	14.7	14.7	14.5	14.1	13.8	13.4	13.0	12.7	12.3	12.3	-	-	-	-	-	-	-	-	-	-	32.8													
36.1	-	12.3	12.5	12.5	12.5	12.3	11.9	11.6	11.2	11.0	10.8	10.8	-	-	-	-	-	-	-	-	-	-	36.1													
39.4	-	-	10.5	10.5	10.5	10.5	10.3	10.1	9.9	9.7	9.4	9.4	-	-	-	-	-	-	-	-	-	-	39.4													
45.9	-	-	7.7	7.7	7.7	7.7	7.7	7.9	7.7	7.7	7.4	7.2	7.2	-	-	-	-	-	-	-	-	-	45.9													
52.5	-	-	-	5.9	5.9	5.7	5.9	5.9	5.9	5.7	5.7	5.7	5.7	-	-	-	-	-	-	-	-	-	52.5													
59.1	-	-	-	-	4.4	4.4	4.4	4.4	4.4	4.4	4.4	4.4	4.4	-	-	-	-	-	-	-	-	-	59.1													
65.6	-	-	-	-	-	3.3	3.3	3.3	3.3	3.3	3.3	3.3	3.3	3.3	-	-	-	-	-	-	-	-	65.6													
72.2	-	-	-	-	-	-	-	2.4	2.4	2.4	2.4	2.4	2.4	2.4	-	-	-	-	-	-	-	-	72.2													
78.7	-	-	-	-	-	-	-	-	-	1.7	1.7	1.7	1.7	1.7	-	-	-	-	-	-	-	-	78.7													
85.3	-	-	-	-	-	-	-	-	-	1.3	1.3	1.3	1.3	1.3	1.3	-	-	-	-	-	-	-	85.3													
1)	17.1	11.2	7.7	5.5	3.9	2.6	1.7	1.1	-	-	-	-	-	-	-	-	-	-	-	-	-	-	1)													

Operation

MS

4,000 lbs													19.7 ft x 21.3 ft		40°		360°		ASME B30.5															
ft													34.3 ft		42.4 ft		50.5 ft		58.6 ft		66.8 ft		74.9 ft		83.0 ft		91.1 ft		99.2 ft		107.4 ft		115.5 ft	
ft													1,000 lbs													ft								
9.8	43.2	43.2	-	-	-	-	-	-	-	-	-	-	-	-	-	-	-	-	-	-	-	-	9.8											
11.5	43.2	43.2	-	-	-	-	-	-	-	-	-	-	-	-	-	-	-	-	-	-	-	-	11.5											
13.1	43.2	43.2	43.2	-	-	-	-	-	-	-	-	-	-	-	-	-	-	-	-	-	-	-	13.1											
14.8	43.2	43.2	43.2	-	-	-	-	-	-	-	-	-	-	-	-	-	-	-	-	-	-	-	14.8											
16.4	43.2	43.2	41.0	38.8	-	-	-	-	-	-	-	-	-	-	-	-	-	-	-	-	-	-	16.4											
19.7	35.2	33.5	31.7	30.4	29.1	-	-	-	-	-	-	-	-	-	-	-	-	-	-	-	-	-	19.7											
23.0	27.1	26.8	25.5	24.6	23.8	22.9	-	-	-	-	-	-	-	-	-	-	-	-	-	-	-	-	23.0											
26.2	21.3	21.3	21.3	20.5	19.8	19.1	18.5	-	-	-	-	-	-	-	-	-	-	-	-	-	-	-	26.2											
29.5	17.6	17.6	17.6	17.4	16.7	16.3	15.8	15.4	-	-	-	-	-	-	-	-	-	-	-	-	-	-	29.5											
32.8	-	14.7	14.7	14.7	14.3	13.8	13.6	13.2	-	-	-	-	-	-	-	-	-	-	-	-	-	-	32.8											
36.1	-	12.3	12.3	12.3	12.3	12.1	11.6	11.4	11.0	-	-	-	-	-	-	-	-	-	-	-	-	-	36.1											
39.4	-	-	10.5	10.5	10.5	10.5	10.1	9.9	9.7	9.4	-	-	-	-	-	-	-	-	-	-	-	-	39.4											
45.9	-	-	7.7	7.7	7.7	7.7	7.7	7.7	7.4	7.2	7.0	-	-	-	-	-	-	-	-	-	-	-	45.9											
52.5	-	-	-	5.7	5.7	5.7	5.7	5.7	5.7	5.7	5.5	-	-	-	-	-	-	-	-	-	-	-	52.5											
59.1	-	-	-	-	4.4	4.4	4.4	4.4	4.4	4.4	4.4	-	-	-	-	-	-	-	-	-	-	-	59.1											
65.6	-	-	-	-	-	3.3	3.3	3.3	3.3	3.3	3.3	-	-	-	-	-	-	-	-	-	-	-	65.6											
72.2	-	-	-	-	-	-	2.4	2.4	2.4	2.4	2.4	-	-	-	-	-	-	-	-	-	-	-	72.2											
78.7	-	-	-	-	-	-	-	1.7	1.7	1.7	1.7	-	-	-	-	-	-	-	-	-	-	-	78.7											
85.3	-	-	-	-	-	-	-	-	1.3	1.1	1.1	1.1	1.1	-	-	-	-	-	-	-	-	-	85.3											
1)	16.7	11.0	7.4	5.2	3.7	2.6	1.7	1.1	-	-	-	-	-	-	-	-	-	-	-	-	-	-	1)											

4,000 lbs													19.7 ft x 21.3 ft		20°		360°		ASME B30.5															
ft													34.3 ft		42.4 ft		50.5 ft		58.6 ft		66.8 ft		74.9 ft		83.0 ft		91.1 ft		99.2 ft		107.4 ft		115.5 ft	
ft													1,000 lbs													ft								
16.4	43.2	-	-	-	-	-	-	-	-	-	-	-	-	-	-	-	-	-	-	-	-	-	16.4											
19.7	35.0	-	-	-	-	-	-	-	-	-	-	-	-	-	-	-	-	-	-	-	-	-	19.7											
23.0	26.6	26.4	-	-	-	-	-	-	-	-	-	-	-	-	-	-	-	-	-	-	-	-	23.0											
26.2	21.1	21.1	-	-	-	-	-	-	-	-	-	-	-	-	-	-	-	-	-	-	-	-	26.2											
29.5	17.4	17.4	17.4	-	-	-	-	-	-	-	-	-	-	-	-	-	-	-	-	-	-	-	29.5											
32.8	-	14.5	14.5	14.3	-	-	-	-	-	-	-	-	-	-	-	-	-	-	-	-	-	-	32.8											
36.1	-	12.3	12.1	12.1	-	-	-	-	-	-	-	-	-	-	-	-	-	-	-	-	-	-	36.1											
39.4	-	-	10.3	10.3	10.3	-	-	-	-	-	-	-	-	-	-	-	-	-	-	-	-	-	39.4											
45.9	-	-	-	7.7	7.4	7.4	-	-	-	-	-	-	-	-	-	-	-	-	-	-	-	-	45.9											
52.5	-	-	-	5.7	5.7	5.7	5.7	5.7	-	-	-	-	-	-	-	-	-	-	-	-	-	-	52.5											
59.1	-	-	-	-	4.4	4.1	4.1	4.1	4.1	-	-	-	-	-	-	-	-	-	-	-	-	-	59.1											
65.6	-	-	-	-	-	3.3	3.0	3.0	3.3	-	-	-	-	-	-	-	-	-	-	-	-	-	65.6											
72.2	-	-	-	-	-	-	2.4	2.4	2.4	2.4	-	-	-	-	-	-	-	-	-	-	-	-	72.2											
78.7	-	-	-	-	-	-	-	1.7	1.7	1.7	1.7	-	-	-	-	-	-	-	-	-	-	-	78.7											
85.3	-	-	-	-	-	-	-	-	1.1	1.1	1.1	1.1	-	-	-	-	-	-	-	-	-	-	85.3											
1)	16.9	11.2	7.7	5.2	3.7	2.6	1.7	1.1	-	-	-	-	-	-	-	-	-	-	-	-	-	-	1)											

Operation





MS

2,400 lbs													19.7 ft x 21.3 ft		60°		360°		ASME B30.5																	
ft													34.3 ft		42.4 ft		50.5 ft		58.6 ft		66.8 ft		74.9 ft		83.0 ft		91.1 ft		99.2 ft		107.4 ft		115.5 ft		ft	
ft													1,000 lbs													ft										
9.8	43.2	43.2	-	-	-	-	-	-	-	-	-	-	-	-	-	-	-	-	-	-	-	-	9.8													
11.5	43.2	43.2	-	-	-	-	-	-	-	-	-	-	-	-	-	-	-	-	-	-	-	-	11.5													
13.1	43.2	43.2	43.2	43.2	-	-	-	-	-	-	-	-	-	-	-	-	-	-	-	-	-	-	13.1													
14.8	43.2	43.2	43.2	43.2	-	-	-	-	-	-	-	-	-	-	-	-	-	-	-	-	-	-	14.8													
16.4	43.2	41.8	39.4	37.4	35.7	-	-	-	-	-	-	-	-	-	-	-	-	-	-	-	-	-	16.4													
19.7	33.9	32.1	30.6	29.3	27.9	26.8	25.7	-	-	-	-	-	-	-	-	-	-	-	-	-	-	-	19.7													
23.0	25.7	25.7	24.6	23.5	22.7	22.0	21.1	20.5	-	17.8	-	-	-	-	-	-	-	-	-	-	-	-	23.0													
26.2	20.5	20.5	20.5	19.6	18.9	18.2	17.8	17.1	16.7	16.3	15.4	-	-	-	-	-	-	-	-	-	-	-	26.2													
29.5	16.5	16.7	16.7	16.5	16.0	15.4	14.9	14.5	14.1	13.6	13.4	-	-	-	-	-	-	-	-	-	-	-	29.5													
32.8	-	13.8	13.8	13.8	13.6	13.2	12.7	12.3	12.1	11.6	11.4	-	-	-	-	-	-	-	-	-	-	-	32.8													
36.1	-	11.6	11.6	11.6	11.6	11.2	11.0	10.8	10.3	10.1	9.9	-	-	-	-	-	-	-	-	-	-	-	36.1													
39.4	-	-	9.7	9.9	9.9	9.7	9.4	9.2	9.0	8.8	8.5	-	-	-	-	-	-	-	-	-	-	-	39.4													
45.9	-	-	7.0	7.0	7.0	7.0	7.2	7.0	6.8	6.8	6.6	-	-	-	-	-	-	-	-	-	-	-	45.9													
52.5	-	-	-	5.2	5.2	5.2	5.2	5.2	5.2	5.2	5.0	-	-	-	-	-	-	-	-	-	-	-	52.5													
59.1	-	-	-	-	3.9	3.9	3.9	3.9	3.9	3.9	3.9	-	-	-	-	-	-	-	-	-	-	-	59.1													
65.6	-	-	-	-	-	2.8	2.8	2.8	2.8	2.8	2.8	-	-	-	-	-	-	-	-	-	-	-	65.6													
72.2	-	-	-	-	-	-	1.9	1.9	2.2	2.2	2.2	-	-	-	-	-	-	-	-	-	-	-	72.2													
78.7	-	-	-	-	-	-	-	-	1.5	1.5	1.5	-	-	-	-	-	-	-	-	-	-	-	78.7													
1)	16.0	10.3	7.0	4.8	3.3	2.2	1.5	-	-	-	-	-	-	-	-	-	-	-	-	-	-	-	1)													

2,400 lbs													19.7 ft x 21.3 ft		40°		360°		ASME B30.5																	
ft													34.3 ft		42.4 ft		50.5 ft		58.6 ft		66.8 ft		74.9 ft		83.0 ft		91.1 ft		99.2 ft		107.4 ft		115.5 ft		ft	
ft													1,000 lbs													ft										
9.8	43.2	43.2	-	-	-	-	-	-	-	-	-	-	-	-	-	-	-	-	-	-	-	-	9.8													
11.5	43.2	43.2	-	-	-	-	-	-	-	-	-	-	-	-	-	-	-	-	-	-	-	-	11.5													
13.1	43.2	43.2	43.2	-	-	-	-	-	-	-	-	-	-	-	-	-	-	-	-	-	-	-	13.1													
14.8	43.2	43.2	43.2	-	-	-	-	-	-	-	-	-	-	-	-	-	-	-	-	-	-	-	14.8													
16.4	43.2	41.2	39.0	36.8	-	-	-	-	-	-	-	-	-	-	-	-	-	-	-	-	-	-	16.4													
19.7	33.5	31.7	30.2	28.8	27.5	-	-	-	-	-	-	-	-	-	-	-	-	-	-	-	-	-	19.7													
23.0	25.5	25.3	24.2	23.3	22.4	21.6	-	-	-	-	-	-	-	-	-	-	-	-	-	-	-	-	23.0													
26.2	20.2	20.2	20.0	19.4	18.7	18.0	17.4	-	-	-	-	-	-	-	-	-	-	-	-	-	-	-	26.2													
29.5	16.5	16.5	16.5	16.3	15.8	15.2	14.7	14.3	-	-	-	-	-	-	-	-	-	-	-	-	-	-	29.5													
32.8	-	13.8	13.8	13.8	13.4	13.0	12.5	12.1	-	-	-	-	-	-	-	-	-	-	-	-	-	-	32.8													
36.1	-	11.4	11.4	11.4	11.4	11.0	10.8	10.5	10.1	-	-	-	-	-	-	-	-	-	-	-	-	-	36.1													
39.4	-	-	9.7	9.7	9.7	9.7	9.2	9.0	8.8	8.5	-	-	-	-	-	-	-	-	-	-	-	-	39.4													
45.9	-	-	7.0	7.0	7.0	7.0	7.0	7.0	7.0	6.8	6.6	6.3	-	-	-	-	-	-	-	-	-	-	45.9													
52.5	-	-	-	5.2	5.2	5.2	5.2	5.2	5.2	5.0	4.8	-	-	-	-	-	-	-	-	-	-	-	52.5													
59.1	-	-	-	-	3.9	3.9	3.9	3.9	3.9	3.9	3.7	-	-	-	-	-	-	-	-	-	-	-	59.1													
65.6	-	-	-	-	-	2.8	2.8	2.8	2.8	2.8	2.8	-	-	-	-	-	-	-	-	-	-	-	65.6													
72.2	-	-	-	-	-	-	1.9	1.9	1.9	1.9	1.9	-	-	-	-	-	-	-	-	-	-	-	72.2													
78.7	-	-	-	-	-	-	-	-	1.3	1.3	1.3	-	-	-	-	-	-	-	-	-	-	-	78.7													
1)	15.8	10.1	6.8	4.8	3.3	2.2	1.5	-	-	-	-	-	-	-	-	-	-	-	-	-	-	-	1)													

Operation

MS

☰ 2,400 lbs		 19.7 ft x 21.3 ft		 20°		360°		ASME B30.5					
		34.3 ft	42.4 ft	50.5 ft	58.6 ft	66.8 ft	74.9 ft	83.0 ft	91.1 ft	99.2 ft	107.4 ft	115.5 ft	
ft	1,000 lbs											ft	
16.4	43.2	-	-	-	-	-	-	-	-	-	-	-	16.4
19.7	33.0	-	-	-	-	-	-	-	-	-	-	-	19.7
23.0	25.3	25.1	-	-	-	-	-	-	-	-	-	-	23.0
26.2	20.0	20.0	-	-	-	-	-	-	-	-	-	-	26.2
29.5	16.5	16.3	16.3	-	-	-	-	-	-	-	-	-	29.5
32.8	-	13.6	13.6	13.4	-	-	-	-	-	-	-	-	32.8
36.1	-	11.4	11.2	11.2	-	-	-	-	-	-	-	-	36.1
39.4	-	-	9.4	9.4	9.4	-	-	-	-	-	-	-	39.4
45.9	-	-	-	6.8	6.8	6.8	-	-	-	-	-	-	45.9
52.5	-	-	-	5.2	5.0	5.0	5.0	-	-	-	-	-	52.5
59.1	-	-	-	-	3.7	3.7	3.7	3.7	3.7	-	-	-	59.1
65.6	-	-	-	-	-	2.8	2.8	2.6	2.8	-	-	-	65.6
72.2	-	-	-	-	-	-	1.9	1.9	1.9	-	-	-	72.2
78.7	-	-	-	-	-	-	-	1.3	1.3	-	-	-	78.7
1)	15.8	10.3	7.0	4.8	3.3	2.2	1.5	-	-	-	-	-	1)

Notes to Lifting Capacity

Ratings are in compliance with ASME B30.5.
Lifting capacities do not exceed 85 % of tipping load.

Weight of hook blocks and slings is part of the load, and is to be deducted from the capacity ratings.
Consult operation manual for further details.

Note: Data published herein is intended as a guide only and shall not be construed to warrant applicability for lifting purposes.
Crane operation is subject to the computer charts and operation manual both supplied with the crane.

TECHNICAL DESCRIPTION

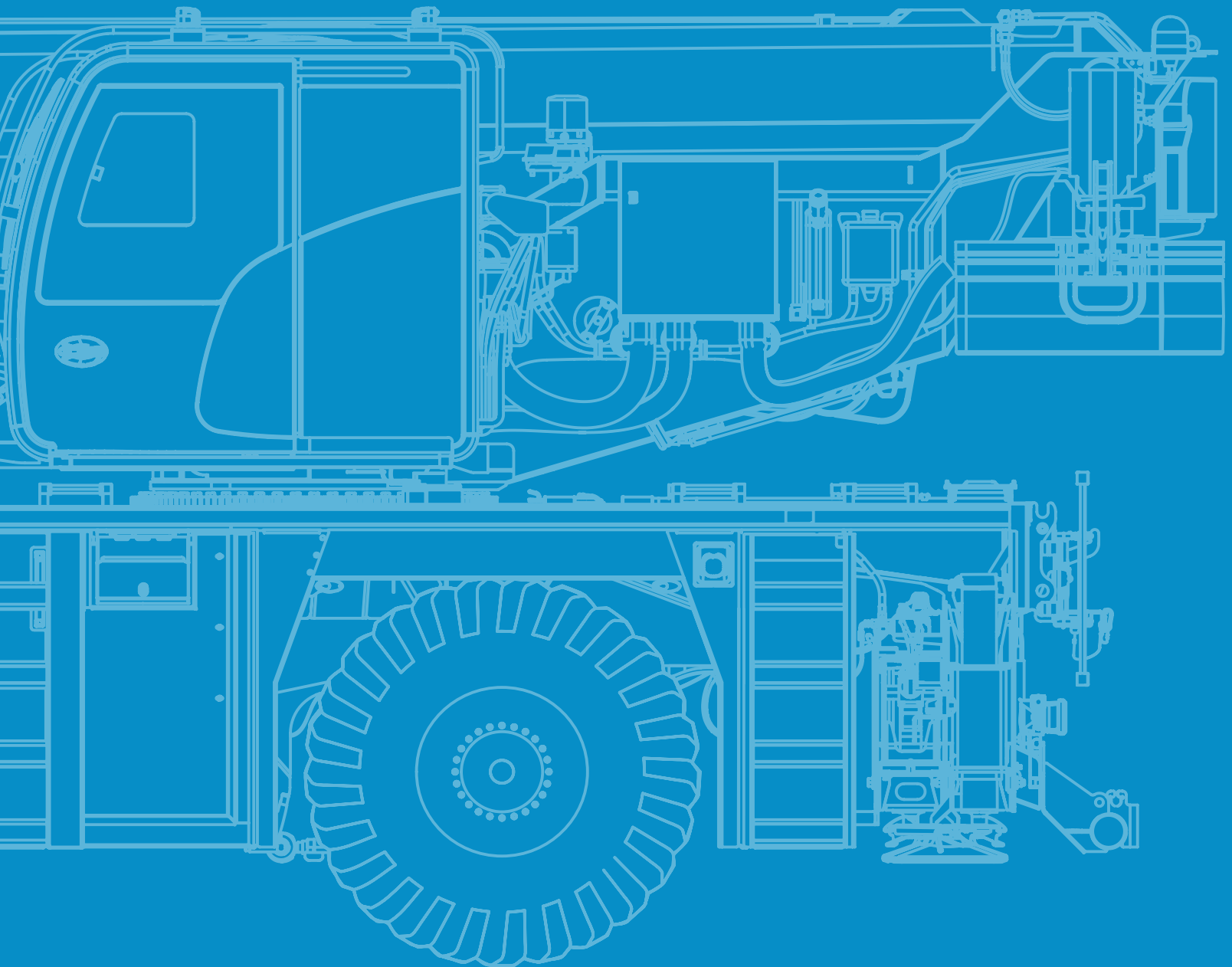

Technical Description

Basic machine

Equipment carrier

Engine 231-5	Cummins B6.7; Diesel engine; 231 kW / 2000 ¹ /min (310 HP), torque 1288 Nm / 1500 ¹ /min; The engine complies with EU Stage V/Tier4F; Exhaust system complete stainless steel with SCR catalyzer.
Fuel tank	79 gallons Diesel (no RME / biodiesel); 11 gallons Ad-Blue tank.
Transmission ZF 6WG210	Automated gearbox; 6 forward speeds and 1 reverse.
Axles 4 x 2 x 4	All axles steered, axle 2 driven and equipped with selectable transverse lock.
Suspension	Hydro pneumatic suspension with axle load compensation; Hydraulically lockable; Manual or automatic leveling alternatively.
Steering	Dual circuit hydro servocom steering with emergency steering pump; Active rear axle steering.
Brakes	Pneumatic dual circuit service brake with antilock system, acting on all wheels; Drum brakes; Additional engine-exhaust brake; Spring-loaded parking brake.
Tires	Tires size 445/95 R25 (16.00R25); Steel rim 11-25/1,7".
Cab 2550	Type 8.4 ft; Adjustable driver seat, armrests and pneumatic suspension; Height and tilt-adjustable steering wheel; Auxiliary/passenger seat; Powered door windows; Tinted glass; Electrically adjustable rear-view mirrors, heated; Radio; Seat heating; Heating engine-dependent; Aircondition.
Rear view camera	Display in carrier cab; Cameras installed on rear of vehicle.
Drive lights	Including low beams, high beams, daytime running lights, fog lights and cornering lights.
Central lubrication	Automatic central lubrication system for the lubricating points at the carrier.
Outriggers	H-4-Point design; Vertical and horizontal movement fully hydraulic; Manual or automatic levelling alternatively; 5 outrigger bases: 7.9 ft, 10.8 ft, 14.1 ft, 16.7 ft and 19.7 ft.
Outrigger basis monitoring	Individual monitoring of horizontal stroke; Deviation warning in crane cab.
Outrigger load indicator	The outrigger load is indicated in the operator cab and the outrigger control box.
Electronic immobiliser system	Prevents uncontrolled carrier mobilisation; Incl. 5 ignition keys.
Pneumatic tire filling plug	For self-filling of the wheels.

Equipment superstructure

Telescopic boom HA35	34.3 ft - 115.5 ft; Fully hydraulic telescoping system; Attachments for all equipment and extensions; 5 sheaves integrated in boom head for max. capacity of 70,300 lbs.
Boom luffing	1 luffing cylinder with automatic lowering brake valve.
Rotary drive	Single slewing gear unit with spring-loaded multi-disc brake.
H1	Hoist with spring-loaded multi-disc brake; Resolver (hoist rotation indicator).
Counterweight 14,300 lbs	5 pieces; Automatic rigging system.
Control system	Enabling 3 simultaneous working movements; Electric pilot controls via 2 two-axis joysticks.
Operator aids	IC-1, with integrated electronic load moment indicator in accordance with EN13000; Color display; Displaying of current operating conditions, load charts, fault indicator; Signal lights indicating LMI-load; Crane data logger.
IC-1 Plus incl. Flex Base	Smart crane control system for main boom operation enabling higher lifting capacities especially over outriggers. Enables safe use of the full capacity of the crane even in asymmetric outrigger configurations. Flexible and independent outrigger positioning possible. Capacity precalculation for +/- 30° slewing angle and radius area. In-cab lift simulation.
IC-1 Remote	IC-1 Remote, Tadano telematic system.
Working range limiter	Displaying and programmability of the work range limits by IC-1.
Cab 875	Type 2.87 ft; Tilt infinitely variable 16°; Sliding window rear; Fold-out front window; Extendable side pedestal, front pedestal; Handrails; Tinted safety glass; Pull-down sun visor; Radio; Seat heating; Heating engine-independent; Aircondition.
Central lubrication	Automatic central lubrication system for the lubricating points at the superstructure.

Technical Description

Additional equipment

Carrier

Axles 4 x 4 x 4	All axles steered, driven and equipped with selectable transverse lock.
Wear-free auxiliary brake	Wear-free auxiliary eddy-current brake at 2nd axle.
Tires	4 tires; Tire size 525/80 (20.5R25).
Tadano Surround View	360° view during road travelling; Speed dependent; Indication in display of carrier cabin. Usable as assistance system when entering jobsite with indication of outrigger positions and tailswing of counterweight.
TailGUARD	Reversing assistant for a safe reversing with optical and acoustical warnings and automatic brake system.

Superstructure

Heavy lift attachment	2 additional sheaves; For total 7 sheaves at boom head; Max. capacity of 80,000 lbs.
Load supervision camera	Camera mounted on main boom head to supervise the load hook from above; Incl. boom head light on boom head.

Handling

Remote control	Control of rigging and superstructure operations via wireless remote control.
Moving out of crane cab	Control of carrier out of crane cab, enables machine moving when rigged, possible even under load.
E-Pack	Electro-hydraulic pump aggregate for emission free crane operation.

Extensions

HAV 29.5 ft	Lattice swing-away jib, manual offset 0°/20°/40°; 2-sheave head; Incl. transport storage.
MS (runner)	4.6 ft; Variable assembly jib with manual offset; 3-sheaves, for max. 43,200 lbs lifting capacity.
Boom head traverse 33,100 lbs	For runner, installation in front of sheave axis; Incl. shackle and hook.

Hook Blocks

Hook block 110,200 lbs, 7-sheaves	Max. capacity 80,000 lbs; 1,000 lbs; Single hook, red with white signal stripes.
Hook block 88,200 lbs, 5-sheaves	Max. capacity 77,200 lbs; 620 lbs; Single hook, red with white signal stripes.
Hook block 55,100 lbs, 3-sheaves	Max. capacity 50,100 lbs; 440 lbs; Single hook, red with white signal stripes.
Hook block 22,050 lbs, 1-sheave	Max. capacity 21,900 lbs; 330 lbs; Single hook, red with white signal stripes.
Hook 8,800 lbs	Max. capacity 7,400 lbs; 165 lbs; Single hook, red.

Further additional equipment on request!

Weight data may deviate from posted values based on road / travel configuration, equipment configuration, and component weight tolerances.

tac.sales@tadano.com
www.tadano.com

Tadano Ltd.

Kanda Square 18th Floor, 2-2-1 Kanda-Nishikicho, Chiyoda-ku, Tokyo 101-0054, Japan
Phone: +81-3-6811-7309 (International Division)

Tadano America Corporation

4242 West Greens Road, Houston, TX 77066
Phone: +1 (281) 869-00300 · Fax: +1 (281) 869-0040



Reaching new heights

