

AS-32C

TELESCOPIC CRAWLER BOOM

MODEL HIGHLIGHTS

- 360° turntable rotation
- Unrestricted range of motion
- Low emission engine
- Low ground pressure
- Non-marking rubber tracks

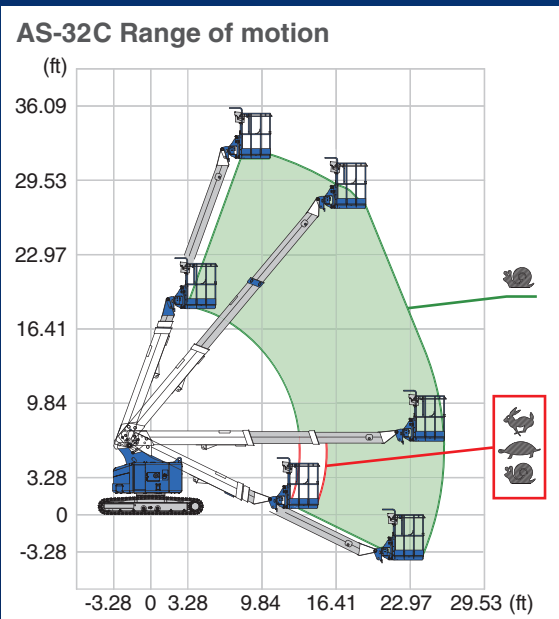

Model	AS-32C
Max. platform capacity	440 lb
Platform size	6'4" x 2'11" x 3'7.3"
Max. work height	37'10"
Max. outreach	25'11"

Allows more workers, with more materials and tools, to be more productive!
We Know Crawlers!

Model		AS-32C	
SPECIFICATIONS			
Max. work height	37'10"	POWER SOURCE	
Max. platform height	31'10"	Engine type	Kubota D1105
Max. outreach	25'11"	Rated power	19.3 HP / 2400 min ⁻¹
Allowable tilt	5°	Fuel tank capacity	10.8 gal
Max. platform capacity	440 lb	OPTIONS	
Platform size (L x W x H)	6'4" x 2'11" x 3'7.3"	Generator	Available soon
Platform rotation	180°	LED lighting	
Transport dims (L x W x H)	19'9.4" x 6'8.7" x 7'7"	SAFETY DEVICES	
Machine weight	13,165 lb	Emergency stop	✓
AC outlet to platform (120 V)		Foot switch / Enabling switch	✓
TRAVEL			
Max. travel speed	1.49 mph	Auxiliary lowering control	✓
Travel position ground pressure	6.1 psi	Traveling restriction (on slope)	✓
Max. gradeability	36%	Operation restriction (on slope)	✓
		Overload sensing system	✓
		Battery isolator switch	✓

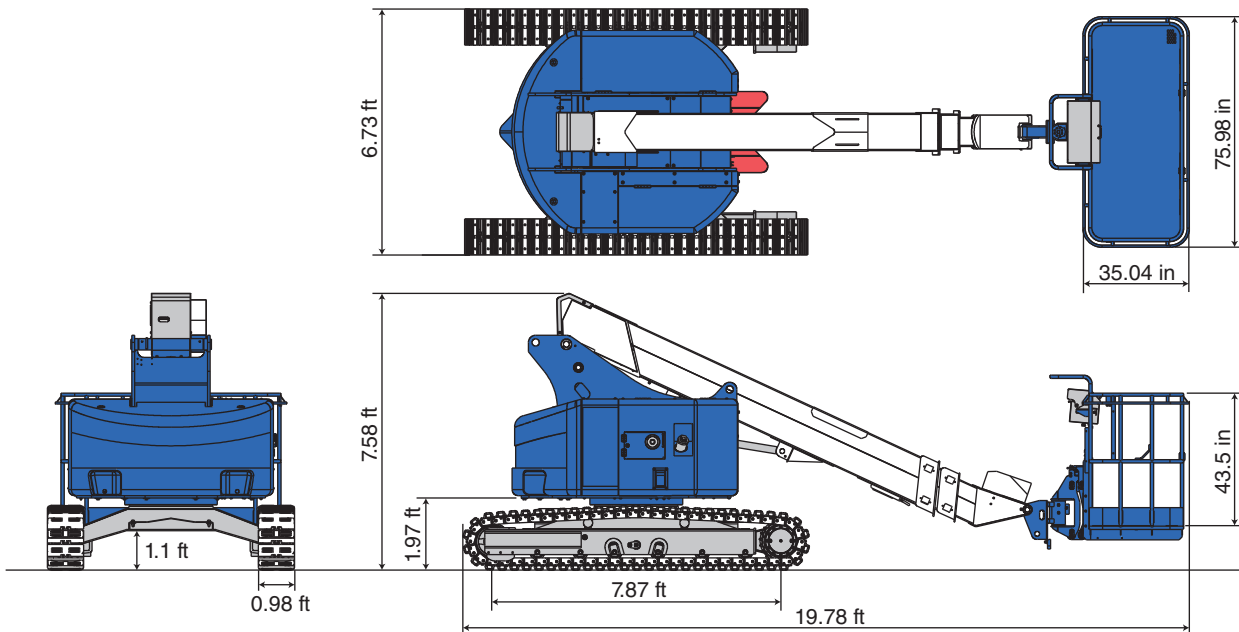

For all our types:



March 2025. Unless otherwise specified, all information in this brochure refers to a standard equipment, and it is intended as general information only. No liability is assumed. Errors reserved. Product specifications and prices are subject to changes without notice. The photographs and/or drawings in this brochure are for illustrative purposes only. For correct and safe operation, the original operating manual and lifting capacity charts are essential. Failure to follow the corresponding Operator's Manual when using our equipment or failure to otherwise act responsibly may result in property damage, serious injury or death. The sole warranty applicable with respect to our equipment is the standard warranty as per general terms and conditions of sales and service (ask your local Tadano dealer for details), and Tadano makes no other warranty, express or implied. All rights reserved. Any use of the trademarks, logos, brand names and model names used herein is prohibited.

© Tadano Ltd. 2025

Tadano Ltd.

Kanda Square 18th Floor, 2-2-1 Kanda-Nishikicho, Chiyoda-ku, Tokyo 101-0054, Japan
Phone: +81-3-6811-7309 (International Division)

tac.sales@tadano.com
www.tadano.com

Tadano America Corporation

4242 West Greens Road, Houston, TX 77066, Phone: +1 (281) 869-00300 · Fax: +1 (281) 869-0040

