

info@tadano.com  
www.tadano.com

**Tadano Ltd.**  
Kanda Square 18th Floor, 2-2-1 Kanda-Nishikicho,  
Chiyoda-ku, Tokyo 101-0054, Japan  
Phone: +81-3-6811-7309



©Tadano Ltd. 2025. Tadano is a registered trademark of Tadano Ltd. or its subsidiaries.



TRUCK LOADER CRANES

# TM-ZX1000 Series

TM-ZX1005HRB



Reaching new heights

# Tadano Quality: advanced safety and power in a single package.

The TM-ZX1000HRB is a more powerful crane that comes with the sophisticated, high-quality Eyes System as standard equipment. Delivering greater safety and peace of mind.

## TM-ZX1000HRB



### Radio Controller with Color LCD\*

\*Liquid-Crystal Display

A radio controller for remotely operating the crane is provided as standard. In addition to displaying the actual load, rated load, and moment load ratio, it also features a large-screen and power-saving color LCD display, has a feature that can customize speed adjustment for various operations, and has a stop switch on it. The "load weight" function makes it possible to check the work progress and the load weight on the vehicle, and also prevents overloading. These features contribute not only to the safety of crane work, but also to the safety of the vehicle when it is traveling.

\*\*The IP rating indicates water proofness and dust proofness as defined in IEC 60529. An IP66K rating indicates an exceptional level of water and dust proofness, ensuring peace of mind.



**WATER &  
DUST-RESISTANCE**  
[IP66K\*\*]



Stop switch

## Feeling Operation

The operating speed when the trigger is pulled during boom slewing or elevating operation can be set to faster or slower than the standard speed.



## Working Height Limit Function

This function to preset the upper limit of the boom height (stop position). This is quite effective in work sites where attention is required to the boom height, such as under power lines and indoors.

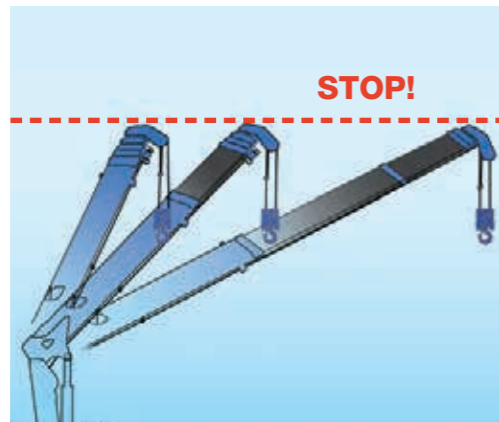

## Jack Interlock

Disables crane operation when the left or right jack is not in contact with the ground.



## Outriggers Asymmetric Extension Width Control

### Optimum Lifting Performance at Any Outrigger Width

Constantly monitors the slewing angle and difference in outrigger extension widths. Crane motion is controlled according to the extension width of each outrigger.

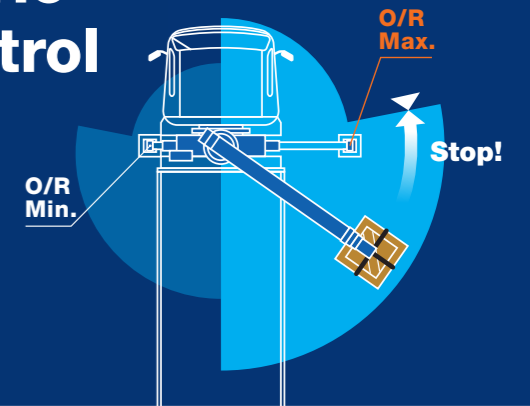

# TM-ZX1 000HRB

## Truck Loader Crane for Large Size Vehicles

### AML (Automatic Moment Limiter)

The AML that monitors crane work safety is equipped as standard and it provides a "strength monitoring" function, which prevents crane overloading, and a "stability monitoring" function, which prevents the crane from tipping over.

Manually entering the number of parts of line in use allows for fine-tuned controls. As an extra level of safety, operation is automatically stopped and warning alarms are triggered once critical parameters are reached.

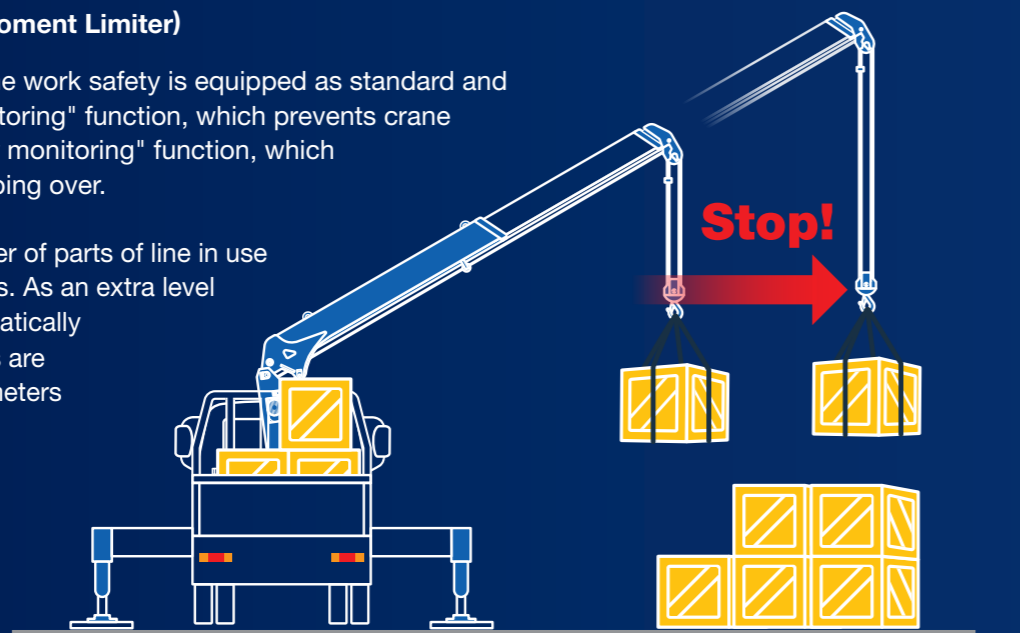

### Safety Lamp Equipped Centralized Control Panel

As operation begins to approach critical levels, safety lamps begin to flash (preliminary warning). If operation continues past this point, warning lights grow more intense once the danger level reaches 100% (limit warning).

See p. 7

#### Limit warning lamp

#### Rated lifting capacity display

Crane strength rated lifting capacity (t) and moment load ratio (%) can be displayed with display switching function.

#### Mode display

Displays the actual load, working height limit value, error code, and other information.



### Limit Warning Lamps

The warning light on the control panel, moment indicator in the radio controller, three-color limit warning lamp at the crane post, and warning alarm function are interlinked with one another.

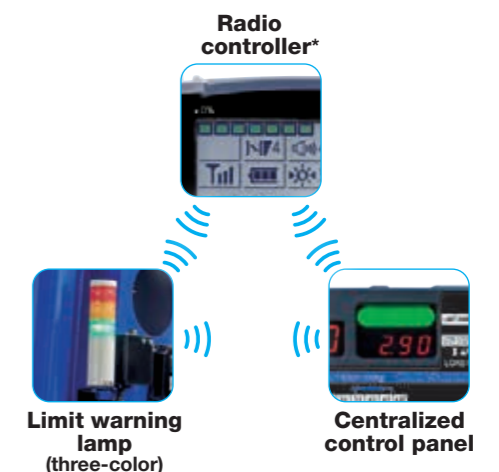



## Hook-in/ out System

Tadano original hook-in system is equipped as standard and enhances work efficiency. During hook-out, the boom raises automatically to avoid hitting cargo.

## Anti-two-block Function

This function stops crane operation (hoisting up, boom elevation, and boom extension) when the hook block touches the weight, and warns the operator with an alarm, to prevent the hook block from hitting the boom head.

## Free of Interference Frequency

The radio controller automatically selects a frequency free of interference out of as many as 40 channels to avoid trouble caused by interference.

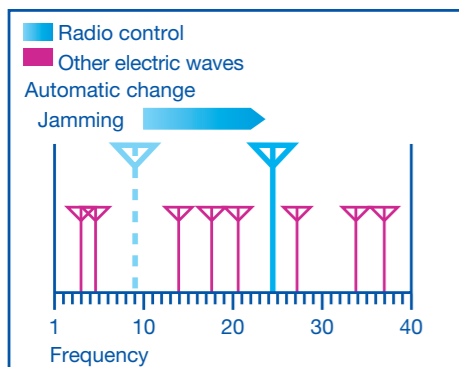

40-channels

## Pentagonal Boom

Tadano's strong and light pentagonal boom made of high tensile steel thoroughly designed and well proven for its quality, strength and smoothness, with a rigid and fine-tuned telescoping boom providing comfortable crane operation.



## Automatic Slewing Lock System

The boom is mechanically locked securely at the boom post base to prevent the boom from accidentally slewing out during travel.

## Powerful Elevating Cylinder

The cylinder use hydraulic, control, and processing technologies cultivated from more than 50 years of manufacturing experience, supporting greater work capacity.

## Cable Follower

The cable follower prevents disorderly cable (wire rope) winding by always pressing the cable onto the winch drum and keeps the wire rope at a right position.



## Big Hydraulic Tank

Big hydraulic tank with approximately 102 liter capacity.

# TM-ZX1000 HRB

## Truck Loader Crane for Large Size Vehicles

## Centralized Control Panel

In addition to the rated lifting capacity table and working range chart, provide digital display and lamps which help safety and efficient operation.

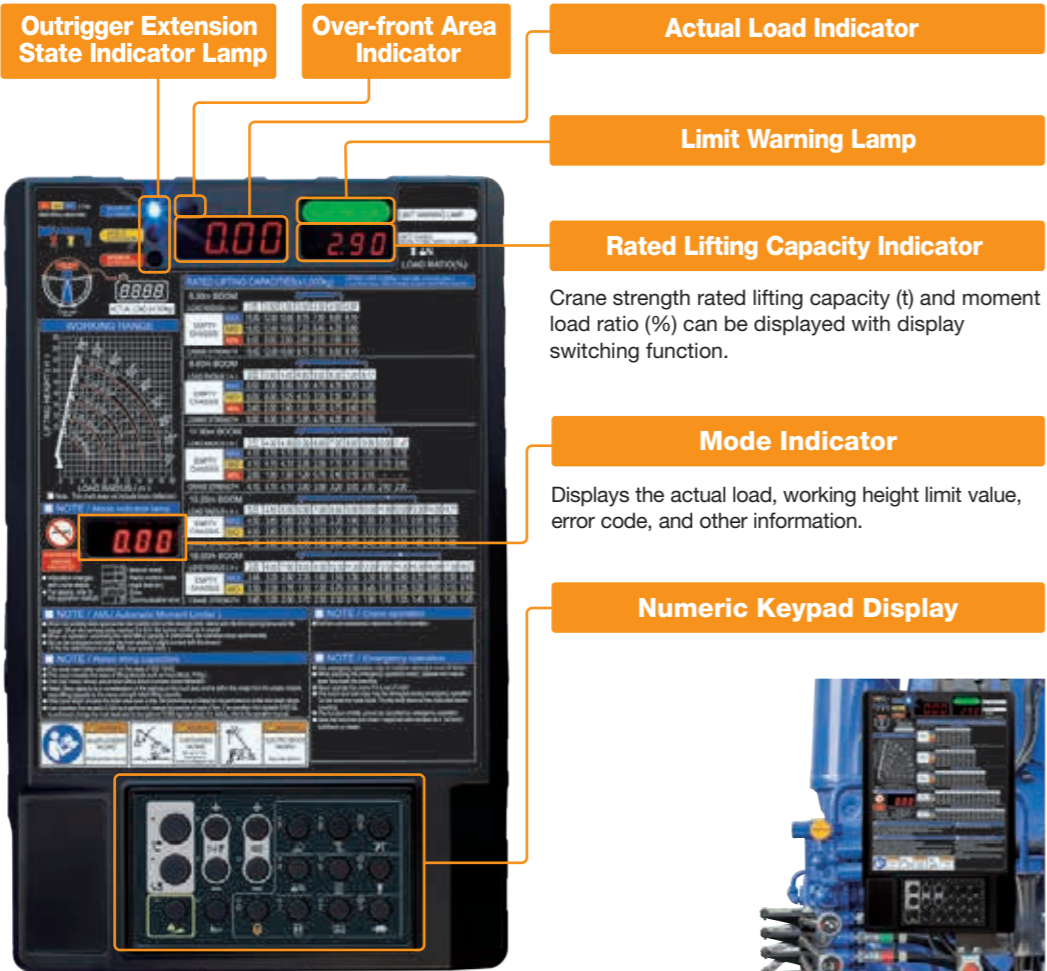

Operation levers and new centralized control panel (on the right side of the main body)

## Emergency Stop

Use this switch to stop the machine movement if the machine cannot be controlled during crane operation, or in an emergency. (Outrigger operation does not stop.)



On machine

## Registering the Hook Block and Number of Parts of Line

Every time the hook block/part line select switch on the control panel is pressed, the indications of the hook block and the number of parts of line change.

## Strong and wide Outrigger

Strong 5.5 m width and powerful outriggers with box structure jacks, an easy and safe lock system together with new universal floats. The lock system is one of the advanced reliable Tadano standard safety systems.

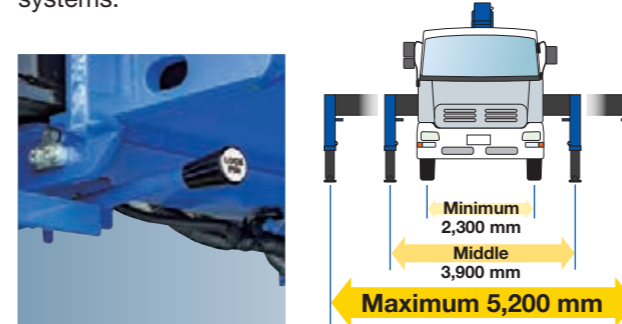

## Spirit Level

A spirit level is provided as standard equipment.



## Tiltable Front Outrigger Jack Float

Tiltable float rotates 360 degrees to fit any ground, for better stability. Large floats reduce ground pressure.

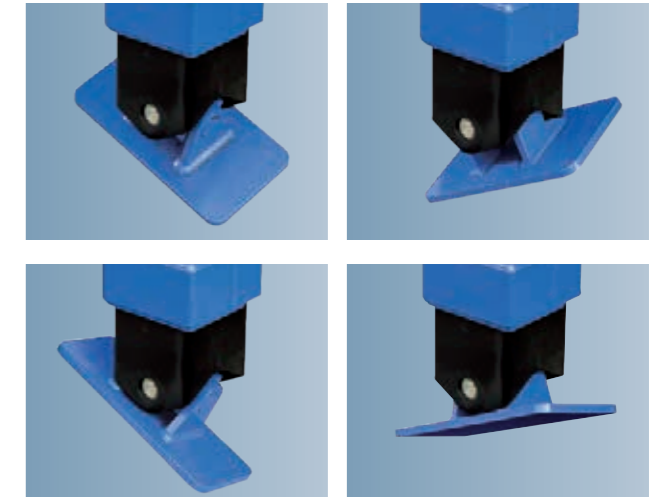
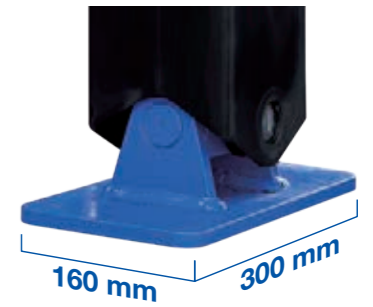

## OPTIONAL EQUIPMENT

### Rear Outriggers

- Outrigger beam extension type
- Outrigger beam non-extension type

### Oil Cooler

The oil cooler maintains the temperature of the hydraulic oil low, keeping it safe and improving the operating efficiency of the crane.

Use the oil cooler to cool the hydraulic oil when the oil temperature rises significantly, such as when the machine is used continuously at high load.



### Maintenance Cock

Convenient when carrying out maintenance such as when changing hydraulic oil or parts.



# TM-ZX1000HRB

## Technical Specifications

Model	TM-ZX1005HRB
MAXIMUM LIFTING CAPACITY	10,000 kg at 1.4 m (8-part line)
CRANE CAPACITY	4,900 kg at 3.1 m (4-part line)
BOOM	Five-sectioned, fully powered partly synchronized telescoping boom of pentagonal box construction with 4 sheaves at boom head
Fully retracted length	4.40 m
Fully extended length	15.92 m
Extension speed	11.5 m in 38 s
Elevation	Elevated by a double-acting Hydraulic cylinder
Raising speed	1° to 82° in 17 s
Boom point	4 sheaves
WINCH	Hydraulic motor driven spur gear speed reduction, provided with mechanical brake and cable follower.
Single line pull	14.72 kN (1,500 kgf)
Single line speed	44 m/min (at 4th layer)
Wire rope	
Diameter x length	10 mm x 95 m
Breaking strength	73.5 kN (7,500 kgf)
Construction	7 x 7 + 6 x Fi (29)
Hook block	4 sheaves
HOOK BLOCK STOWING DEVICE	Hook-in (Mechanically stowed beneath boom top portion)
SLEWING	•Hydraulic motor driven worm gear speed reduction •Continuous 360° full circle slewing on ball bearing slew ring •Automatic slewing lock
Slewing speed	2.2 min <sup>-1</sup> (rpm)
OUTRIGGERS	Hydraulically operated beams and jacks integral with crane frame
Extended width	Min. 2,300 mm center to center (2,460 mm outer to outer), Mid. 3,900 mm center to center (4,060 mm outer to outer), Max. 5,200 mm center to center (5,360 mm outer to outer)
HYDRAULIC SYSTEM	
Hydraulic pump	Single gear pump
Hydraulic motors	Axial piston type for winch and slewing
Control valves	Multiple control valves with integral safety valves
Oil tank capacity	Approx. 102 L
RADIO CONTROLLER	Model : RCS-F (with colored display), Control functions of telescoping, hoisting up and down, elevating, slewing, acceleration, Hook-in, Hook-out, horn, stop operation, and working height limit.
Frequency	40 frequencies in 433 MHz band
Operating power supply	
Transmitter	6V DC, Dry battery R6P(SUM-3) x 4
Control unit	24V DC, Vehicle battery
Transmitter mass	Approx. 670 g (includes batteries)
SAFETY DEVICES	•Anti-two-block device •AML(Automatic Moment Limiter) <Load indication, Load moment ratio indication, Warning alarm, Rated capacity indicator/limiter, Limit warning lamp, Outrigger length detector, Outrigger asymmetric extension width control> •Limit warning lamp(three-color) •WHL(Working Height Limiter) •Boom angle indicator •Over-unwinding prevention •Hook safety latch •Spirit level •Jack interlock •Boom/outrigger stowing reminder alarm •Emergency stop switch •Stop switch on radio controller •Hydraulic safety valves, check valves and holding valves •Rear outrigger extension width detection
OPTIONAL EQUIPMENT	•Outrigger pads •Oil cooler •Rear outriggers (outrigger beam non-extension type) •Maintenance valve
CRANE MASS	Approx. 3,170 kg (Except crane options and mounting parts.)

Note: Each operating speeds show the value when there is no load conditions and the pump delivery is the following conditions.  
 •36 L/min (Slewing speed)  
 •60 L/min (BOOM: Extending speed, Raising speed WINCH: Single line speed)

## Working Range (4 parts of line)

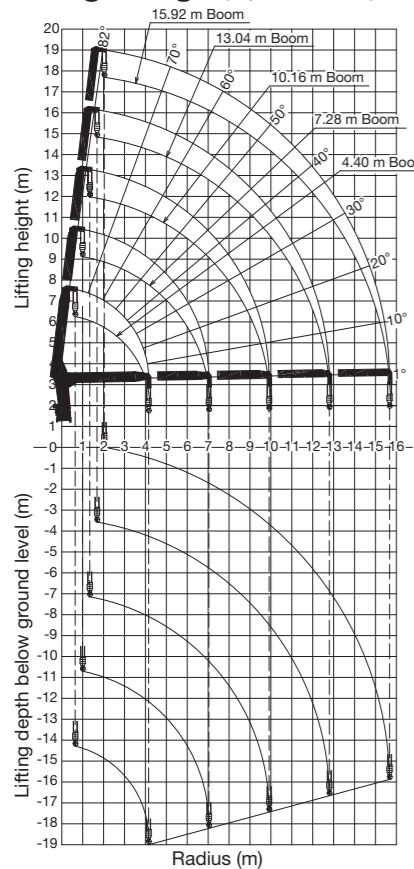

Note: The lifting heights and boom angles are based on a straight (unladen) boom, and allowance should be made for boom deflection obtained under laden conditions.

## Dimensions

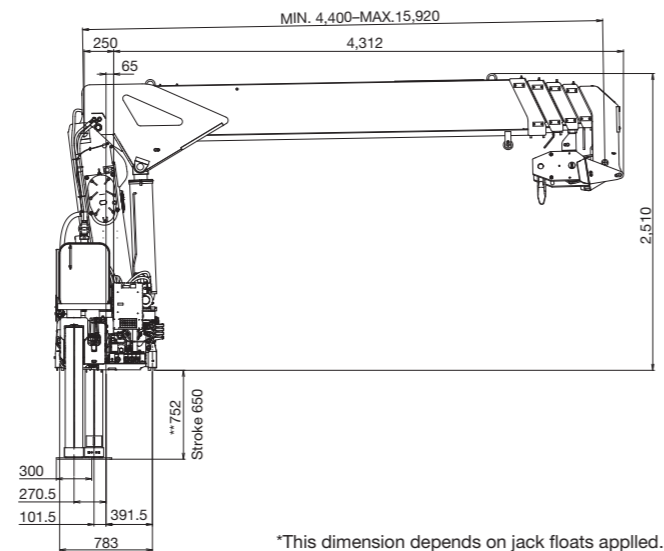

\*This dimension depends on jack floats applied.

## Rated Lifting Capacities (x 1,000 kg)

Table A

● 4.40 m boom		Load radius (m)										
Load radius (m)		1.4 and below	1.85	2.25	3.1	3.5	4.15					
Crane Strength	Max.	10.00	8.00	6.00	4.90	4.20	3.55					
	Mid.	10.00	8.00	6.00	4.90	4.20	3.15					
	Min.	10.00	7.15	4.55	2.40	1.90	1.30					
● 7.28 m boom		Load radius (m)										
Load radius (m)		2.25 and below	3.1	3.5	4.0	4.5	5.0	6.0	7.03			
Crane Strength	Max.	6.00	4.90	4.20	3.70	3.30	2.90	2.20	1.75			
	Mid.	6.00	4.90	4.20	3.35	2.60	2.10	1.45	1.00			
	Min.	4.40	2.30	1.80	1.35	1.05	0.80	0.50	0.25			
● 10.16 m boom		Load radius (m)										
Load radius (m)		4.5 and below	5.0	6.0	7.0	8.0	9.0	9.91				
Crane Strength	Max.	3.00	2.70	2.20	1.80	1.40	1.15	1.00	0.75			
	Mid.	3.00	2.70	2.20	1.60	1.25	1.00	0.75	0.45			
	Min.	1.05	0.80	0.50	0.25	0.20	-	-	-			
● 13.04 m boom		Load radius (m)										
Load radius (m)		4.5 and below	5.0	6.0	7.0	8.0	9.0	10.0	11.0	12.0	12.7	
Crane Strength	Max.	3.00	2.60	2.00	1.70	1.40	1.15	1.00	0.90	0.75	0.65	
	Mid.	3.00	2.60	2.00	1.60	1.25	1.00	0.75	0.65	0.55	0.50	
	Min.	2.60	2.10	1.45	1.00	0.80	0.60	0.45	0.35	0.30	0.25	
● 15.92 m boom		Load radius (m)										
Load radius (m)		5.0 and below	6.0	7.0	8.0	9.0	10.0	11.0	12.0	13.0	14.0	15.67
Crane Strength	Max.	2.60	2.00	1.65	1.40	1.15	1.00	0.90	0.75	0.65	0.55	0.45
	Mid.	2.60	2.00	1.60	1.25	1.00	0.75	0.65	0.55	0.50	0.45	0.35
	Min.	2.10	1.45	1.00	0.80	0.60	0.45	0.35	0.30	0.25	0.20	0.15

- Notes : 1. Rated capacity indicator issues warning with the limit warning lamp and the buzzer when the working state approaches the empty chassis rated lifting capacity. If the alarm is issued, stop operation immediately.  
 2. When the AML is equipped with the rated capacity limiter, an operation stops automatically if the empty chassis rated lifting capacity is exceeded.  
 3. Empty Chassis Rated Capacities in these tables depend on condition that crane is set level on firm level ground.  
 4. This value have been calculated on the basis of ISO 15442.  
 5. This value includes the mass of lifting devices such as hook block (95 kg).  
 6. This load radius shows actual load radius which includes boom deflection.  
 7. If the boom length exceeds the table value even a little, the performance is limited to the performance of the next boom length.  
 8. When the boom length is 13.04 m, a half of the mark on lateral face of the 4th boom section is exposed out of 3rd boom section.  
 9. When the lifting load is heavier than 6,000 kg, number of part lines must be 8. In case of 6,000 kg or less, number of part lines must be 4. Load per line must not surpass 14.7 kN (1,500 kgf).
- |                     |          |           |
|---------------------|----------|-----------|
| Number of part line | 4        | 8         |
| Maximum of load     | 6,000 kg | 10,000 kg |
10. Empty chassis rated lifting capacity varies according to the working area.  
 • Front mounting <over-side, over-rear area> : 100%  
 <over-front area> : 25% (\*1) or 60% (\*1) or 100% (\*1)  
 \*1 : Depend on the types of chassis.  
 11. Empty Chassis Rated Capacities table A and D depend on the types of chassis. (The following table shows guidelines for bodywork vehicles that can achieve the rated lifting capacity tables A and D for vehicles. The rated lifting capacity may not be applicable depending on vehicle specifications. Be sure to carry out a stability inspection to determine which rated lifting capacity tables to apply.)

<b>A</b>	Front 1-axis and rear 1-axis 5000 mm ≤ WB (*2), 16 t ≤ GVW, 2.9 t ≤ CAWf (*3)
	Front 1-axis and rear 2-axis 5500 mm ≤ WB (*2), 20 t ≤ GVW, 2.9 t ≤ CAWf (*3)
<b>D</b>	Front 1-axis and rear 2-axis 5500 mm ≤ WB (*2), 25 t ≤ GVW, 4.0 t ≤ CAWf (*3)

\*2 : From the front axle to the farthest rear axle.  
 \*3 : Chassis front axle weight (excluding crane and mounting parts mass).

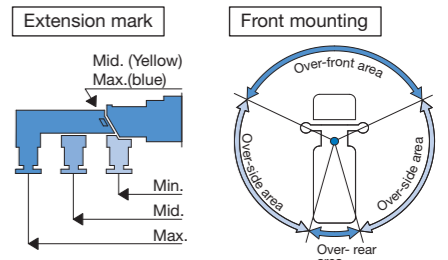
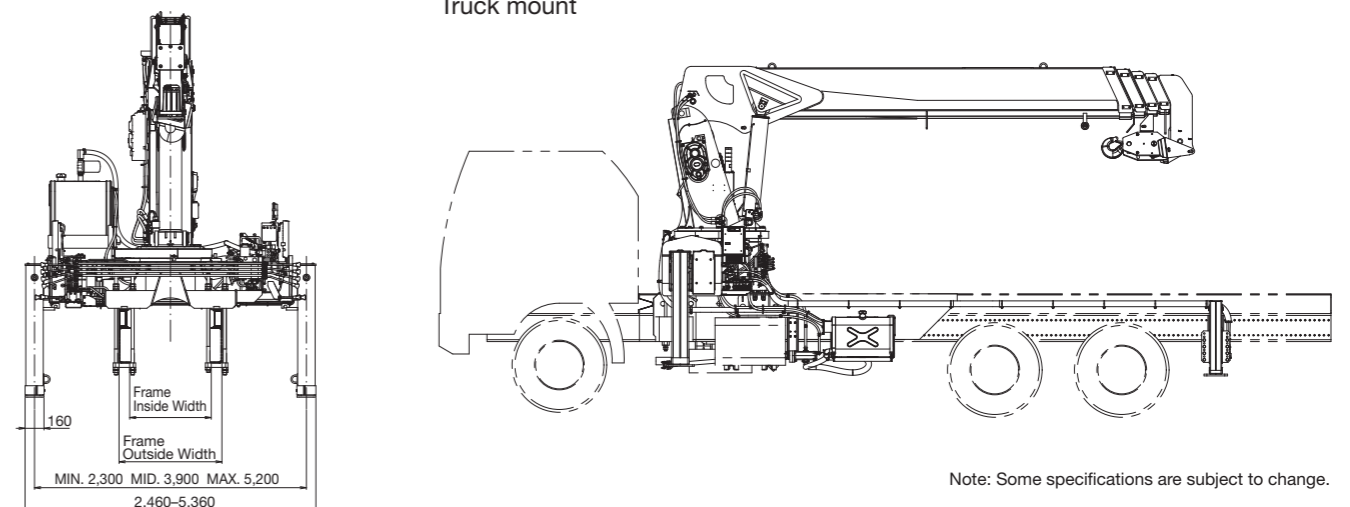

Table D

● 4.40 m boom		Load radius (m)										
Load radius (m)		1.4 and below	1.85	2.25	3.1	3.5	4.15					
Crane Strength	Max.	10.00	8.00	6.00	4.90	4.20	3.55					
	Mid.	10.00	8.00	6.00	4.90	4.20	3.15					
	Min.	10.00	8.00	5.65	3.00	2.40	1.70					
● 7.28 m boom		Load radius (m)										
Load radius (m)		2.25 and below	3.1	3.5	4.0	4.5	5.0	6.0	7.03			
Crane Strength	Max.	6.00	4.90	4.20	3.70	3.30	2.90	2.20	1.75			
	Mid.	6.00	4.90	4.20	3.70	3.30	2.80	1.95	1.40			
	Min.	5.50	2.90	2.30	1.75	1.40	1.10	0.75	0.45			
● 10.16 m boom		Load radius (m)										
Load radius (m)		4.5 and below	5.0	6.0	7.0	8.0	9.0	9.91				
Crane Strength	Max.	3.00	2.70	2.20	1.80	1.40	1.15	1.00	0.75			
	Mid.	3.00	2.70	1.95	1.40	1.15	0.90	0.70	0.45			
	Min.	1.40	1.10	0.75	0.45	0.35	0.20	-	-			
● 13.04 m boom		Load radius (m)										
Load radius (m)		4.5 and below	5.0	6.0	7.0	8.0	9.0	10.0	11.0	12.0	12.7	
Crane Strength	Max.	3.00	2.60	2.00	1.70	1.40	1.15	1.00	0.90	0.75	0.65	
	Mid.	3.00	2.60	2.00	1.70	1.40	1.15	1.00	0.90	0.75	0.65	
	Min.	3.00	2.60	1.95	1.40	1.15	0.90	0.70	0.60	0.50	0.45	
● 15.92 m boom		Load radius (m)										
Load radius (m)		5.0 and below	6.0	7.0	8.0	9.0	10.0	11.0	12.0	13.0	14.0	15.67
Crane Strength	Max.	2.60	2.00	1.65	1.40	1.15	1.00	0.90	0.75	0.65	0.55	0.45
	Mid.	2.60	2.00	1.65	1.40	1.15	1.00	0.90	0.75	0.65	0.55	0.45
	Min.	2.60	1.95	1.40	1.15	0.90	0.70	0.60	0.50	0.45	0.40	0.30

Truck mount



Note: Some specifications are subject to change.