

GTC-1300

130 US TON MAX. CRANE CAPACITY



TADANO
GREEN
SOLUTIONS

- Suitable for alternative fuels

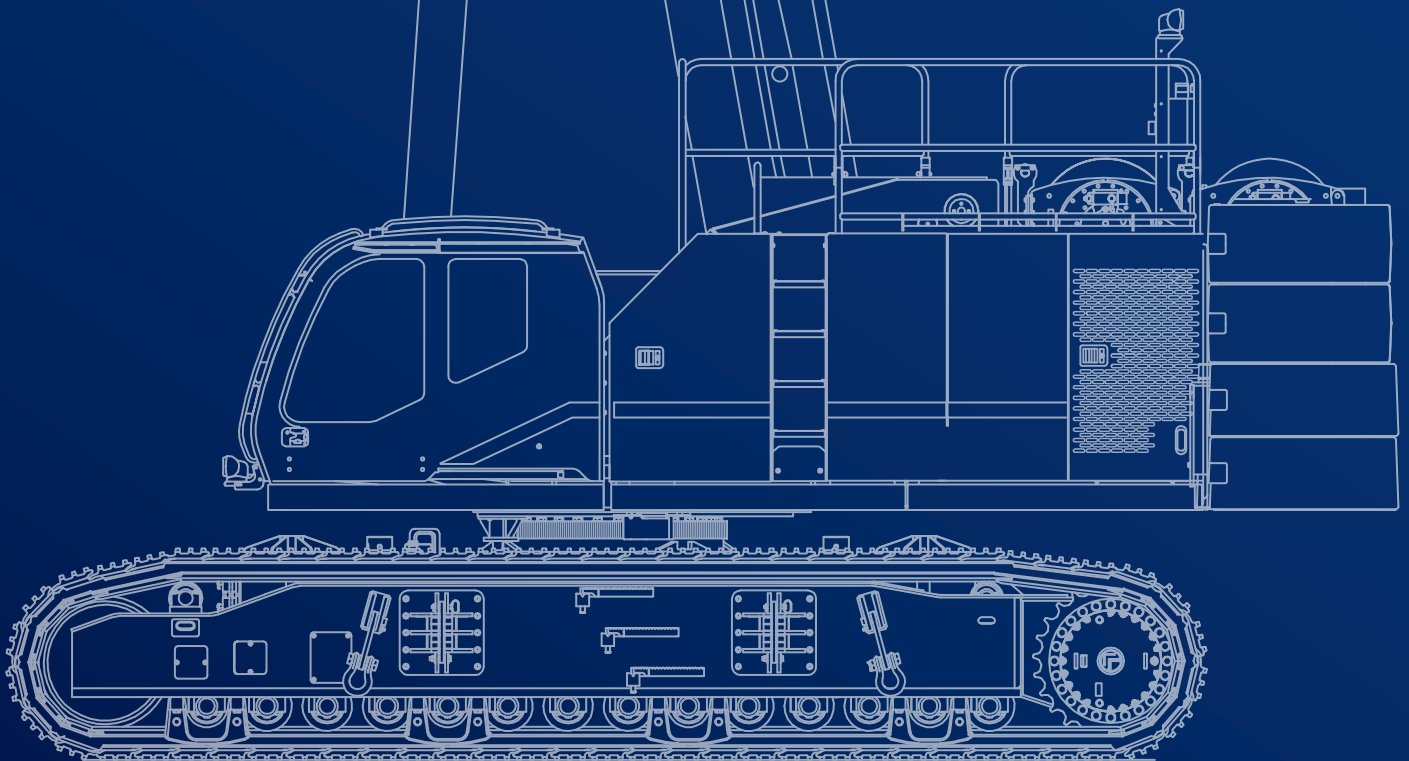



January 2025. Unless otherwise specified, all information in this brochure refers to a standard crane equipment, and it is intended as general information only. No liability is assumed. Errors reserved. Product specifications and prices are subject to changes without notice. The photographs and/or drawings in this brochure are for illustrative purposes only. For correct and safe crane operation, the original operating manual and lifting capacity charts are essential. Failure to follow the corresponding Operator's Manual when using our equipment or failure to otherwise act responsibly may result in property damage, serious injury or death. The sole warranty applicable with respect to our equipment is the standard warranty as per general terms and conditions of sales and service (ask your local Tadano dealer for details), and Tadano makes no other warranty, express or implied. All rights reserved. Any use of the trademarks, logos, brand names and model names used herein is prohibited.

© Tadano Ltd. 2025

Contents

Specifications	7
Vehicle dimensions	8-9
General dimensions	9
Transportation	11
Transport dimensions	12
Transport plan	13
Transport dimensions	14-16
Machine weights	17
Operation	19
Speeds and gradeability	20
Main winch and auxiliary winch performance	20
Hook blocks	21
MB: Main boom	22-30
HLJ: Heavy lift jib	32-33
FJ: Folding swing-away jib	34-38
WP: Work platform	40-41
Notes to Lifting Capacity	42
Technical Description	43
Crane specifications	44-45
Optional equipment	45

Key



	Counterweight		Jib offset angle
	Radius		Max. line pull
	Main boom		Rope length
	Folding swing-away jib		Rope
	Carbody counterweight		Hook block
	Overall width		Number of lines
	Roll / list angle		Assembly weight
	Total weight		Transport variant
	Hook block		Wire rope layer
	Overhaul ball		Total wire rope
	Travel speed		Winch layer diameter
	Gradeability		Wind speed in mph
	Working speeds		

Highlights



155' full power 5-Stage boom; 12.8' to 105' jib (tiltable from 0° to 40°)

Lifting capacities up to 4° out of level with full pick and carry.

Jib capacities to 1.5° or 2.5° out of level depending on jib length.

Dual hook operation with auxiliary nose sheave or jib

Powerful winches with 0.875" rope (23,560 lb pull / 293 ft/min speed)

Tool-free self-rigging operation

Remote control for all rigging operations standard

Full crane operation remote optional

Best in class gradeability at 70%

SPECIFICATIONS

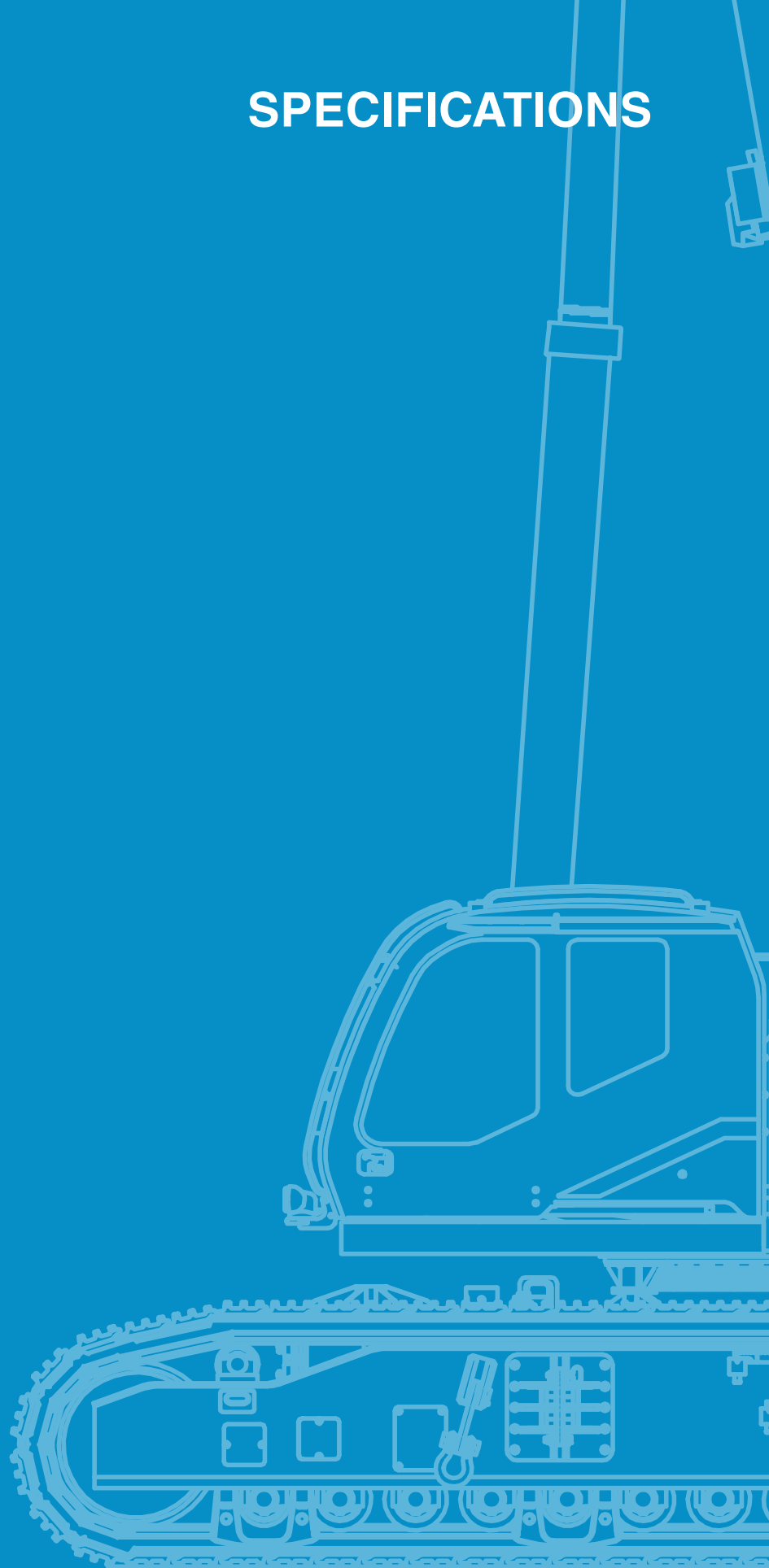

Specifications

Vehicle dimensions

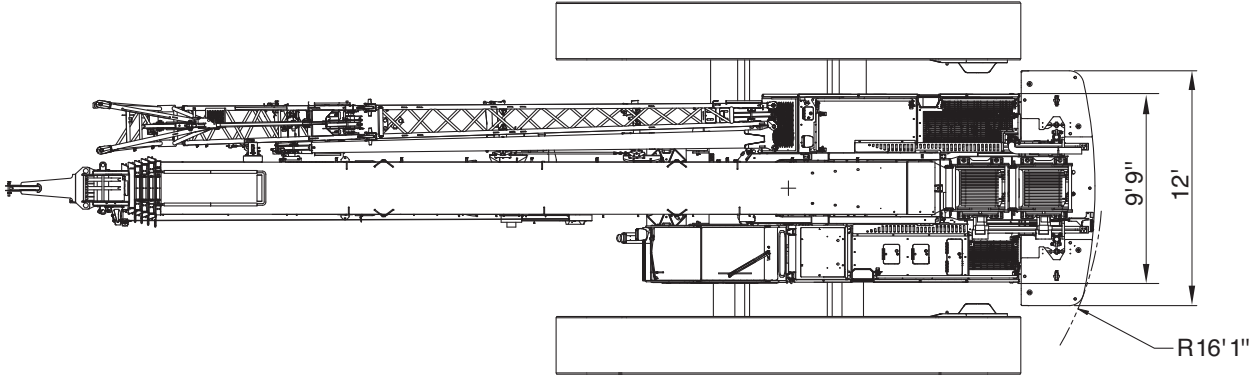
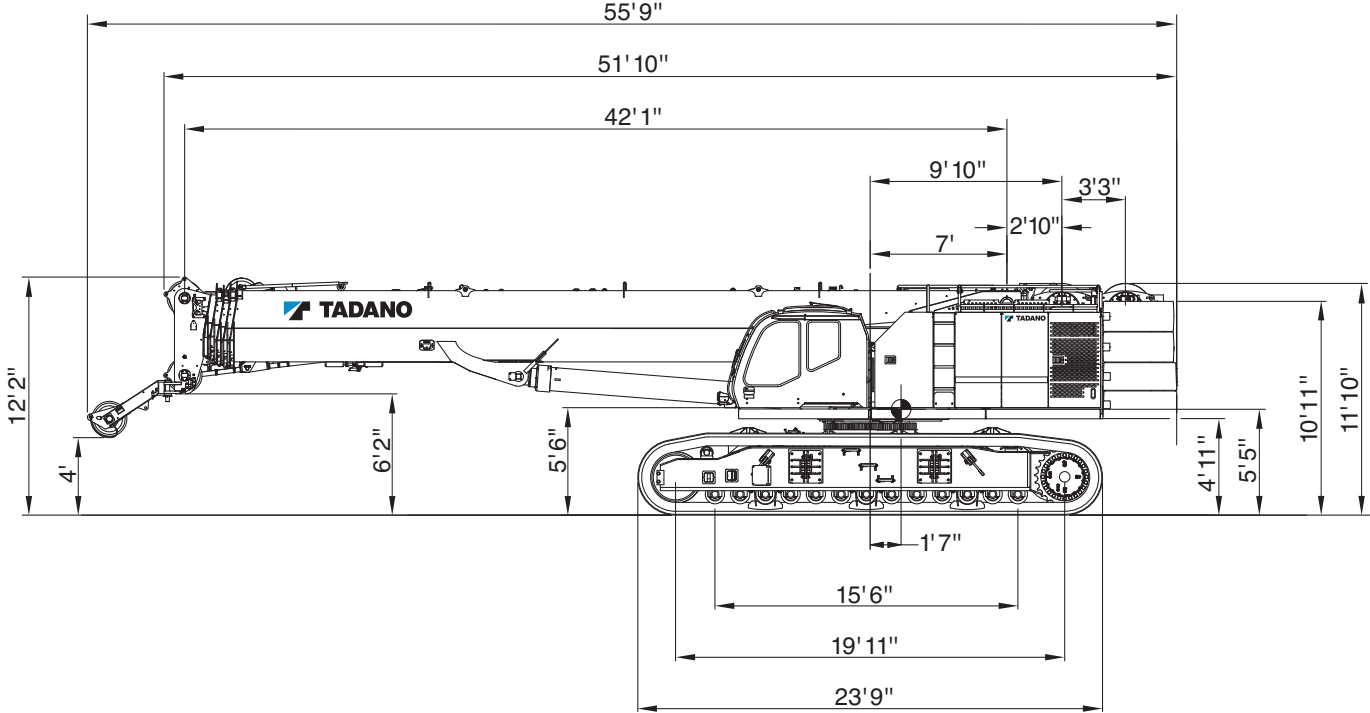

Specifications

Vehicle dimensions

Tracks retracted

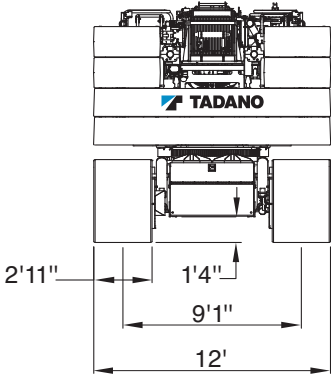

Tracks extended

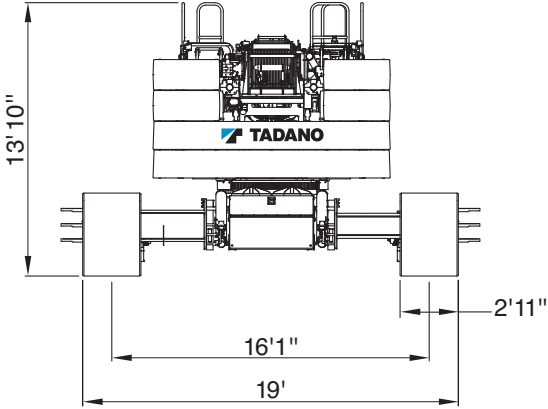

General dimensions

Overall length	51' 10"
Overall width (tracks extended)	19'
Overall width (tracks retracted)	12' 0"
Overall width (tracks removed)	9' 9"
Overall height (working)	13' 10"

TECHNICAL DATA FOR TRANSPORTATION

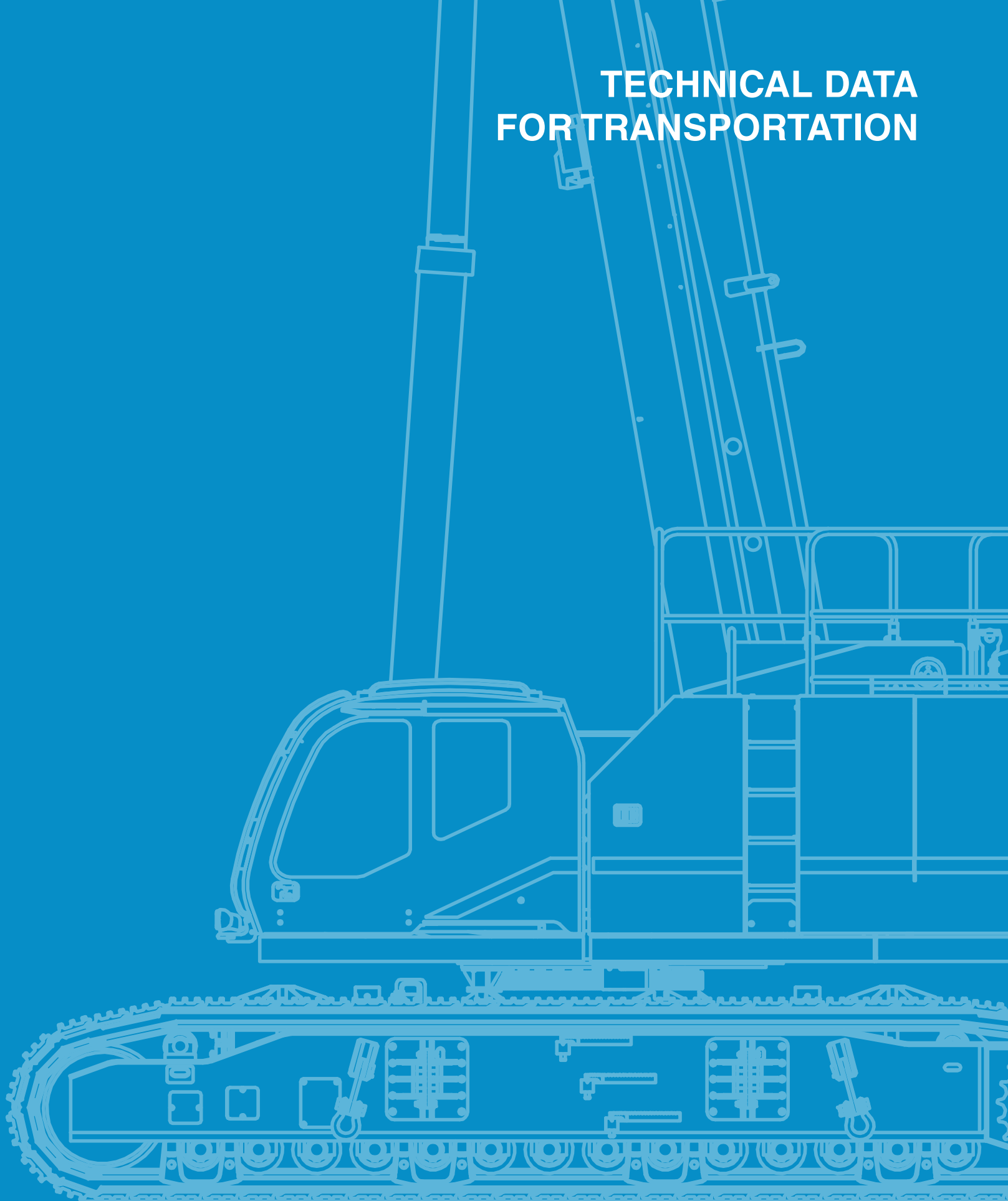

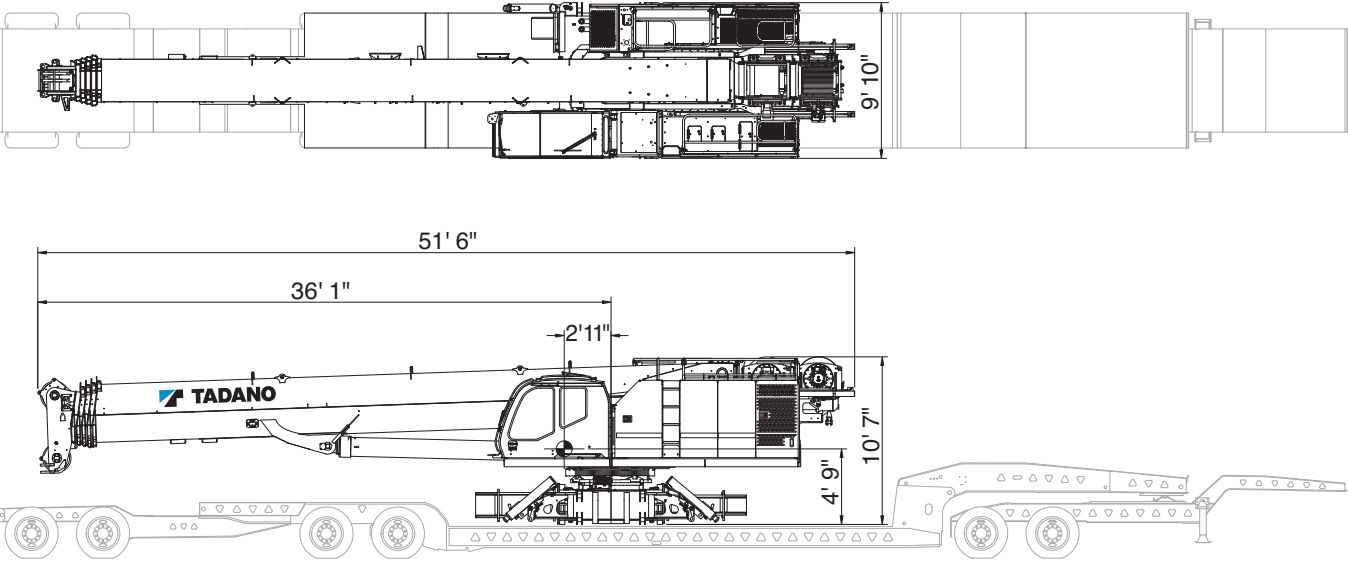

Transportation

Transport dimensions



Transportation

Transport plan							
		Dimensions L x W x H					
			1	2	3	4	5
Crane transporter (with 2 winches, boom, wire rope)	106,726	51' 8" x 9' 10" x 10' 7"	X				
Left track frame	30,300	23' 9" x 3' 10" x 4' 2"		X			
Right track frame	30,300	23' 9" x 3' 10" x 4' 2"			X		
Counterweight A	23,350	4' 2" x 12' 0" x 3' 11"				X	
Counterweight B - 1 piece	23,350	4' 1" x 12' 0" x 1' 6"					X
Counterweight C - 1 piece	5,825	3' 5" x 3' 8" x 1' 6"					X
Counterweight C - 1 piece	5,825	3' 5" x 3' 8" x 1' 6"					X
Counterweight C - 1 piece	5,825	3' 5" x 3' 8" x 1' 6"				X	
Counterweight C - 1 piece	5,825	3' 5" x 3' 8" x 1' 6"				X	
Counterweight - Carbody - 1 piece	10,000	3' 1" x 4' 3" x 2' 10"		X			
Counterweight - Carbody - 1 piece	10,000	3' 1" x 4' 3" x 2' 10"			X		
Heavy lift jib	2,300	14' 5" x 2' 9" x 5' 0"				X	
Jib base section	1,003	21' 0" x 2' 4" x 3' 5"				X	
Jib point	1,000	25' 7" x 1' 6" x 2' 3"				X	
Jib insert	1,053	23' 5" x 2' 2" x 3' 4"					X
Jib insert	1,053	23' 5" x 2' 2" x 3' 4"					X
Auxiliary nose sheave	298	4' 1" x 2' 1" x 2' 11"				X	
Hook block - 130 ton	2,257	5' 8" x 1' 11" x 1' 11"		X			
Overhaul ball - 13 ton	440	2' 8" x 1' 0" x 1' 0"			X		
Miscellaneous items (crate)	500	4' 0" x 3' 0" x 3' 0"				X	
Total net weight on trailer (lb)			106,726	42,557	40,740	40,101	37,106

Transportation

Transport dimensions

Main jib

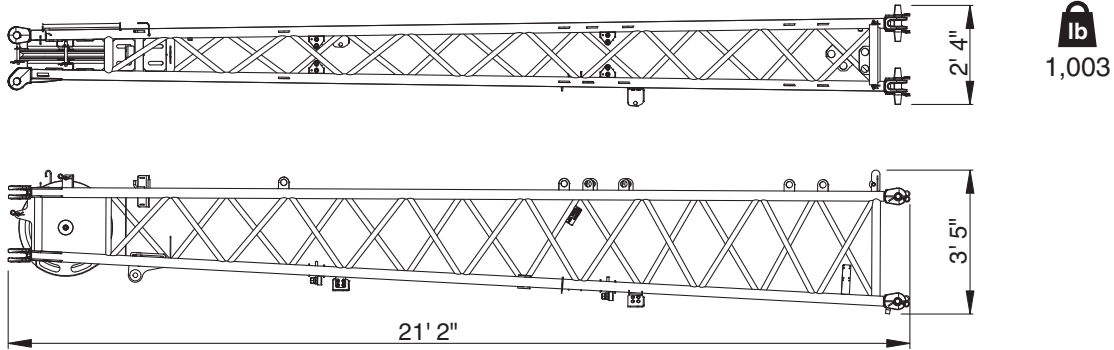

Fly jib

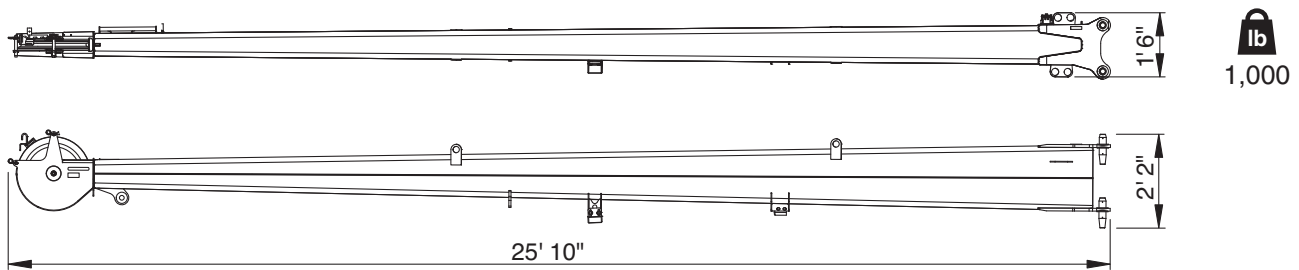

Lattice jib insert

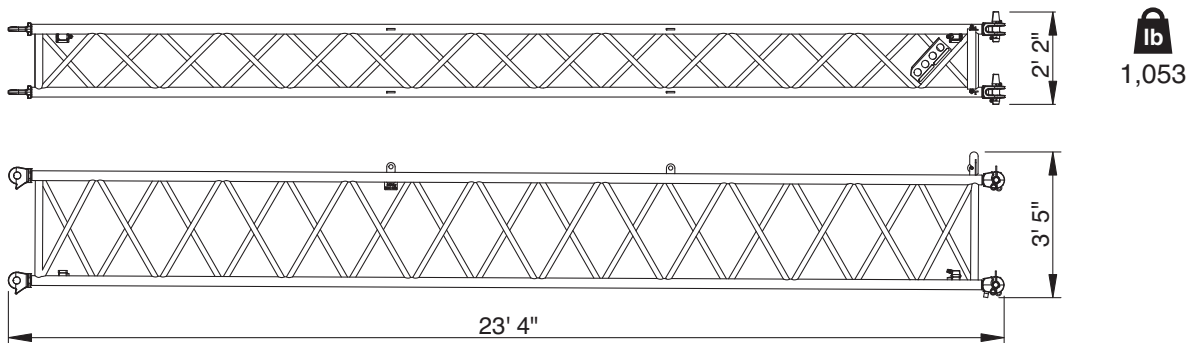

Heavy lift jib

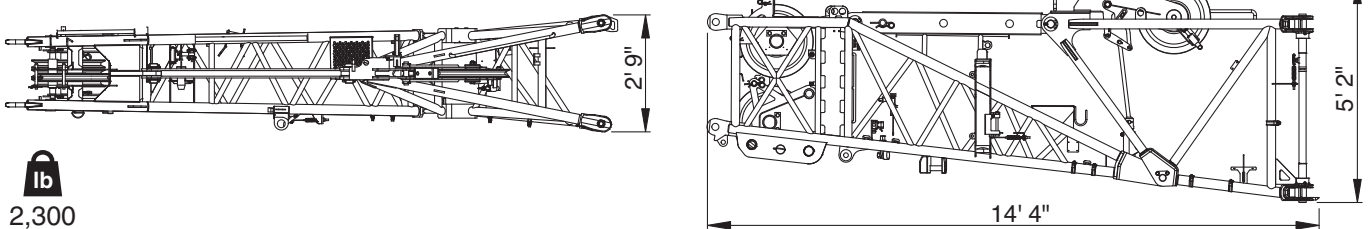

Transportation

Transport dimensions

Auxiliary nose sheave

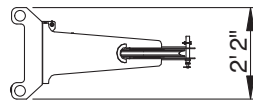
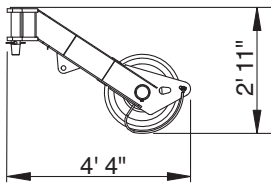

lb
298

Track frame assembly

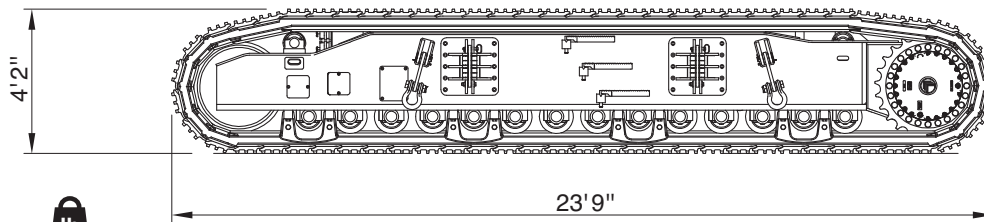

lb
30,300
each

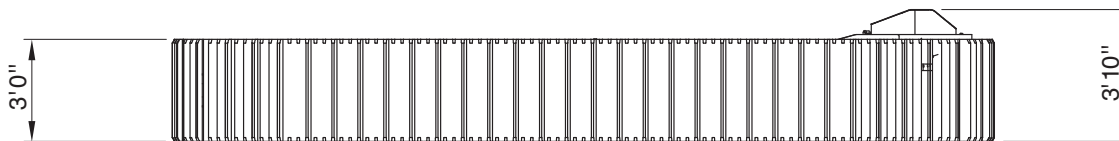

Transportation

Transport dimensions

Configuration A

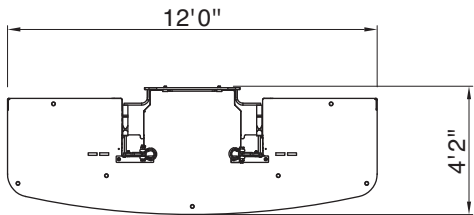

lb
23,350

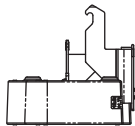
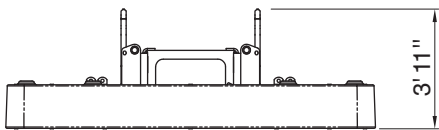

Configuration segment B

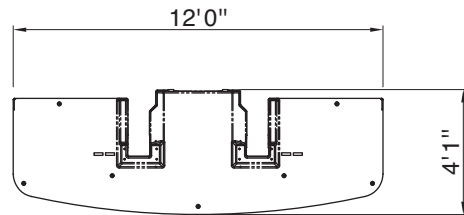

lb
23,350



Configuration B

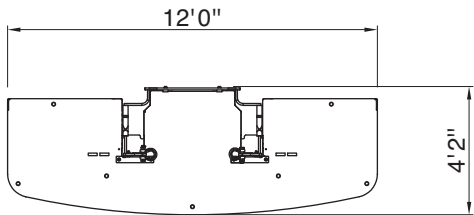

lb
46,700

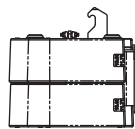
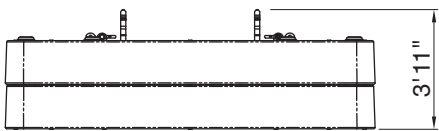

Configuration segment C

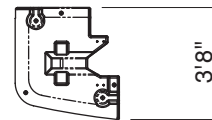

lb
5,825

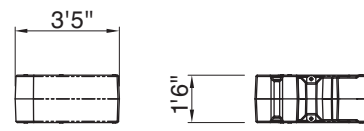

Configuration C

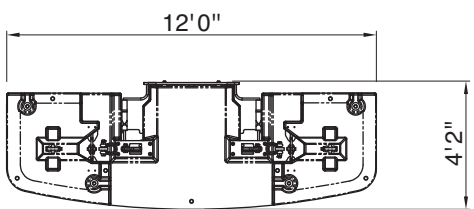

lb
70,000

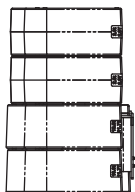
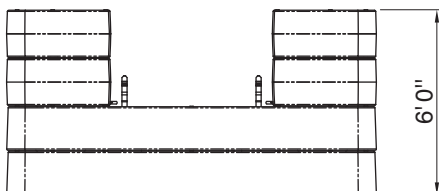





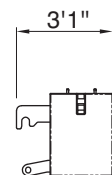
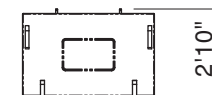
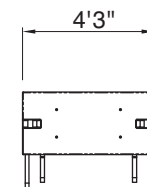



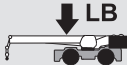

Carbody counterweight – 2 pieces

lb
10,000



Transportation

Machine weights			
	Standard equipment package	264,296 lb	
	Upper Carbody	70,000 lb 20,000 lb	
Standard Crane			
with 5 section – 155 ft boom, full counterweight, auxiliary winch with wire rope and 36 inch 3-bar semi grouser track shoes		259,993 lb	
Standard Crane			
with 5 section – 155 ft boom, auxiliary winch with wire rope (counterweight and track frames removed)		106,466 lb	
Standard Crane			
with auxiliary winch with wire rope (155 ft boom, boom hoist cylinder, counterweight and track frames removed)		70,666 lb	
Optional Equipment			
Heavy lift jib:	12.5 ft	2,300 lb	
Main jib:	33.5 ft	3,303 lb	
Full jib:	59.1 ft	4,303 lb	
Lattice jib insert, 2 pieces: 23.4 ft each		2,106 lb	
Auxiliary nose sheave		298 lb	
	132 ton	 6	2,300 lb
	110 ton	 4	2,275 lb
	80 ton	 3	1,480 lb
	35 ton	 1	939 lb
	13.7 ton		440 lb

TECHNICAL DATA FOR OPERATION

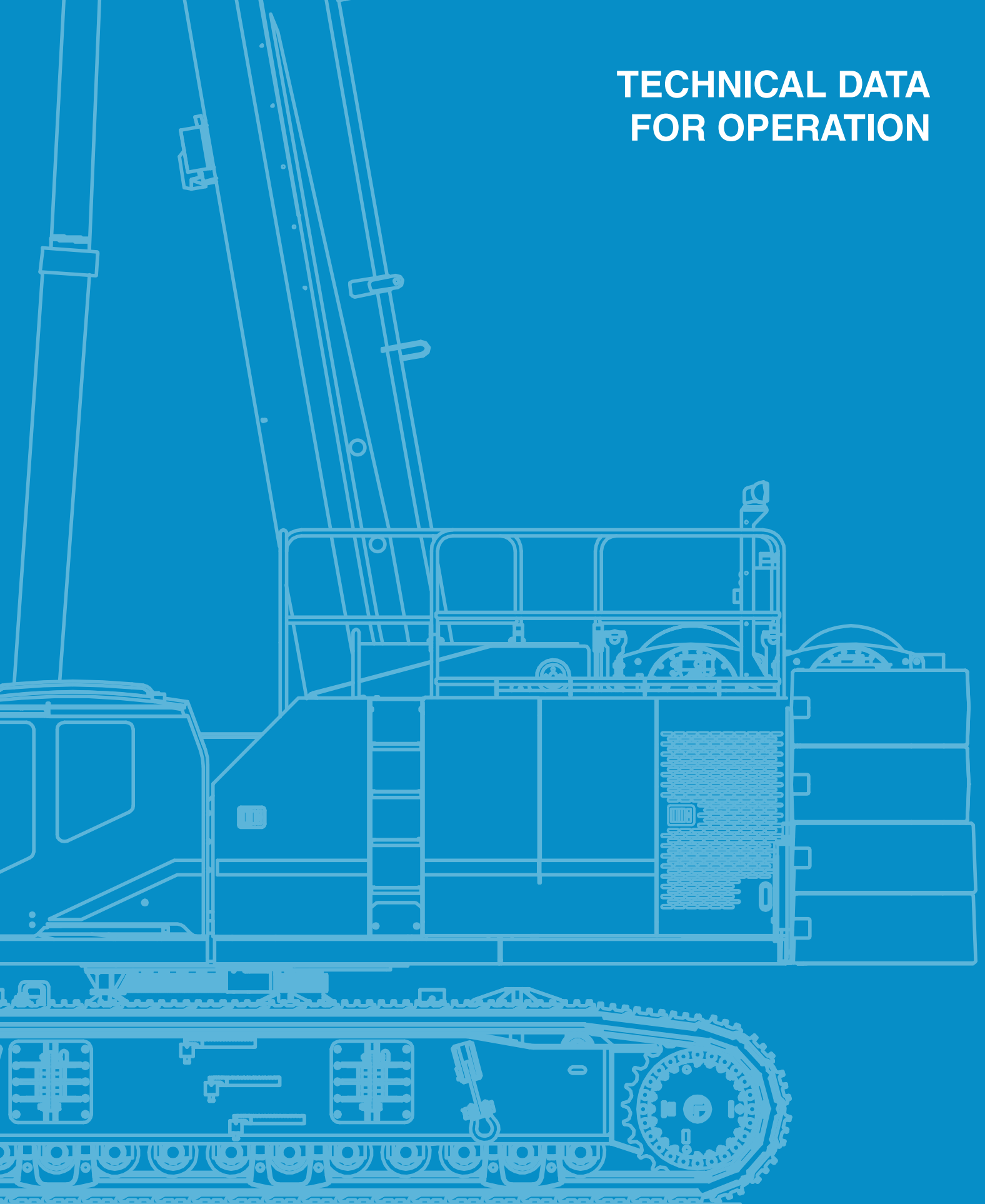



Operation

Speeds and gradeability



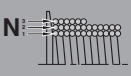

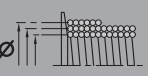
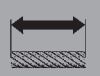
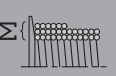

	0.5 mph / 1.4 mph		70 %
---	-------------------	---	------

Main winch and auxiliary winch performance

					
1	23,560 lb	high: 220.1 ft/min. normal: 130.9 ft/min.	18.9 in.	123.3 ft	123.3 ft
2	21,501 lb	high: 238.5 ft/min. normal: 141.7 ft/min.	20.4 in.	133.8 ft	257.1 ft
3	19,759 lb	high: 256.8 ft/min. normal: 152.8 ft/min.	22.0 in.	143.9 ft	401.0 ft
4	18,282 lb	high: 274.9 ft/min. normal: 163.7 ft/min.	23.6 in.	154.2 ft	555.2 ft
5	17,002 lb	high: 293.2 ft/min. normal: 174.5 ft/min.	25.1 in.	164.4 ft	719.6 ft
6	15,894 lb	high: 311.6 ft/min. normal: 185.3 ft/min.	26.7 in.	174.6 ft	894.2 ft

Wire Rope: 22 mm diameter rotation resistant. Line pulls are not based on wire rope strength.

Operation

Hook blocks					
					
1	22,880	13.7-0-22	6	435	8.5 ft
2	45,760	35-1-22	6	939	9.75 ft
3	68,640	35-1-22	6	939	9.75 ft
4	91,520	80-3-22	6	1,480	9.75 ft
5	114,400	80-3-22	6	1,480	9.75 ft
6	137,280	80-3-22	6	1,480	9.75 ft
7	160,160	110-4-22	6	2,275	10.2 ft
8	183,040	110-4-22	6	2,275	10.2 ft
9	205,920	110-4-22	6	2,275	10.2 ft
10	228,800	132-6-22	6	2,300	10.3 ft
11	251,680	132-6-22	6	2,300	10.3 ft
12	274,560	132-6-22	6	2,300	10.3 ft

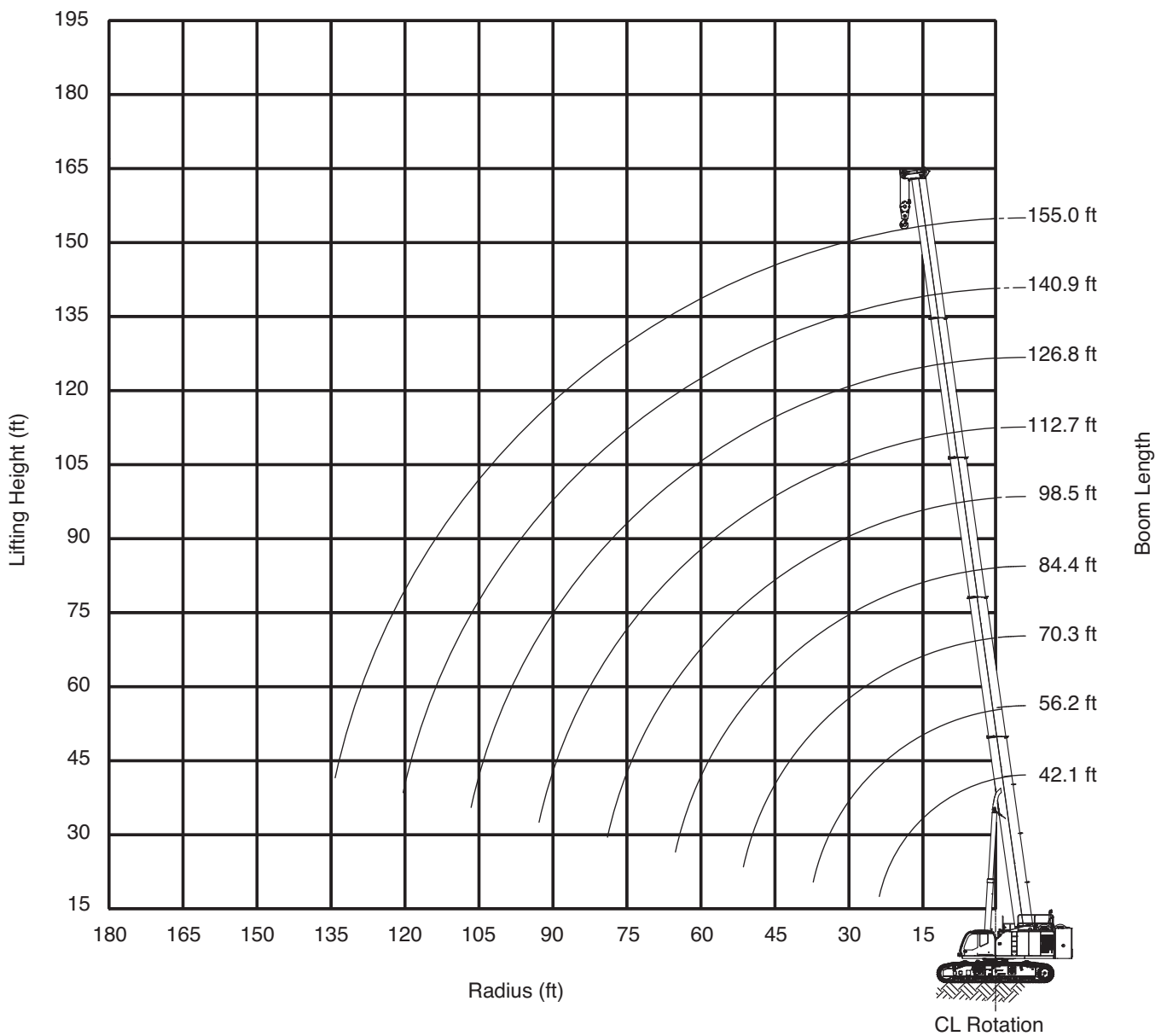

Operation

MB

70,000 lb + 10,000 lb		19'1"				20 mph				360°				ASME B30.5	
42.1 ft		56.2 ft				70.3 ft									
0.5°		1.5°		2.5°		4°		0.5°		1.5°		2.5°		4°	
ft	1,000 lb													ft	
10	264.6	264.6	264.6	264.6	168.7	168.7	168.7	168.7	163.3	163.3	155.5	143.5	10		
12	241.2	241.2	241.2	239.8	168.7	168.7	168.7	168.7	149.9	149.9	146.3	135.8	12		
15	211.1	211.1	211.1	187.9	168.7	168.7	168.7	168.7	145.2	139.1	132.9	124.6	15		
20	164.4	164.4	164.4	135.5	164.2	164.2	154.9	136.1	124.3	119.1	114.7	108.8	20		
25	127.8	123.4	117.4	104.3	127.7	119.5	111.6	101.1	107.6	104.1	100.9	94.6	25		
30	97.2	93.7	90.4	83.5	96.1	90.8	86.0	79.4	94.8	88.4	82.6	74.8	30		
35	76.8	75.3	73.8	-	75.6	72.2	69.1	64.7	74.7	70.4	66.4	61.0	35		
40	-	-	-	-	61.6	59.3	57.2	54.2	60.8	57.8	55.0	51.0	40		
45	-	-	-	-	51.4	49.9	48.5	46.5	50.6	48.4	46.4	43.4	45		
50	-	-	-	-	-	-	-	-	42.9	41.3	39.7	37.5	50		
55	-	-	-	-	-	-	-	-	36.9	35.7	34.5	32.9	55		
60	-	-	-	-	-	-	-	-	32.0	31.2	30.4	29.2	60		

84.4 ft		98.5 ft				112.7 ft									
0.5°		1.5°		2.5°		4°		0.5°		1.5°		2.5°		4°	
ft	1,000 lb													ft	
12	126.1	126.1	117.0	106.2	-	-	-	-	-	-	-	-	-	12	
15	124.5	115.2	107.6	98.4	96.9	96.8	89.5	52.7	-	-	-	-	15		
20	106.2	99.6	94.0	87.0	92.1	85.1	79.5	52.7	65.2	65.2	65.2	43.9	20		
25	91.9	87.1	82.9	77.5	80.5	75.2	70.8	52.7	65.2	65.2	62.1	43.9	25		
30	80.4	76.8	73.7	67.6	70.9	66.9	63.4	52.7	64.6	60.3	56.6	43.9	30		
35	70.7	65.6	61.0	58.3	62.9	59.8	57.0	52.6	57.8	54.4	51.4	43.9	35		
40	58.8	57.2	55.4	50.8	56.2	52.7	48.9	43.9	52.1	49.3	46.9	43.8	40		
45	52.3	49.5	47.0	43.4	46.9	43.8	42.4	40.6	47.0	44.8	41.8	37.4	45		
50	44.6	42.5	40.5	37.7	40.9	39.8	38.8	37.4	41.1	38.3	35.7	32.3	50		
55	38.5	36.8	35.3	33.1	37.2	36.4	35.5	33.0	35.1	32.9	31.3	30.0	55		
60	33.5	32.2	31.0	29.2	34.1	32.9	31.4	29.2	30.3	29.5	28.7	27.7	60		
65	29.5	28.5	27.5	26.1	30.4	29.1	27.9	26.1	27.8	27.2	26.5	25.6	65		
70	26.1	25.3	24.6	23.5	27.0	25.9	24.9	23.5	25.7	25.1	24.6	23.7	70		
75	23.3	22.7	22.2	-	24.1	23.3	22.4	21.2	23.7	23.3	22.8	21.4	75		
80	-	-	-	-	21.7	21.0	20.3	19.3	22.1	21.6	20.7	19.4	80		
85	-	-	-	-	19.5	19.0	18.5	17.7	20.3	19.5	18.8	17.7	85		
90	-	-	-	-	17.8	17.4	17.0	16.4	18.4	17.7	17.1	16.2	90		
95	-	-	-	-	-	-	-	-	16.7	16.2	15.7	14.9	95		
100	-	-	-	-	-	-	-	-	15.3	14.8	14.4	13.8	100		
105	-	-	-	-	-	-	-	-	14.0	13.7	13.4	13.0	105		

Operation

MB

70,000 lb + 10,000 lb		19'1"				20 mph				360°				ASME B30.5	
126.8 ft		140.9 ft				155.0 ft									
0.5°		1.5°		2.5°		4°		0.5°		1.5°		2.5°		4°	
ft	1,000 lb													ft	
20	51.5	51.5	47.7	36.6	-	-	-	-	-	-	-	-	-	-	20
25	64.1	59.0	54.7	36.6	49.5	49.5	47.3	28.4	-	-	-	-	-	-	25
30	58.6	54.0	50.3	36.6	49.5	48.0	44.5	28.4	39.0	39.0	36.9	24.9	24.9	30	
35	53.1	49.3	46.3	36.6	48.3	44.6	41.5	28.4	39.0	37.8	35.2	24.9	24.9	35	
40	48.2	45.2	42.6	36.6	44.5	41.2	38.6	28.4	38.6	35.7	33.5	24.9	24.9	40	
45	44.0	41.5	39.4	36.6	40.9	38.2	35.9	28.4	36.2	33.7	31.7	24.9	24.9	45	
50	40.2	38.1	36.1	32.3	37.6	35.3	33.4	28.4	33.9	31.8	30.1	24.9	24.9	50	
55	36.2	33.6	31.3	28.2	34.8	32.8	31.2	28.2	31.9	30.0	28.2	24.9	24.9	55	
60	31.3	29.2	27.3	24.9	32.0	29.8	27.7	25.7	29.8	28.0	26.5	24.6	24.6	60	
65	27.3	25.6	24.0	23.0	28.1	26.6	25.6	24.0	27.4	26.2	24.9	22.4	22.4	65	
70	23.9	22.8	22.2	21.3	26.0	25.0	23.6	21.5	25.1	23.9	22.3	20.0	20.0	70	
75	21.7	21.1	20.6	19.9	23.8	22.5	21.1	19.3	22.8	21.3	19.9	17.9	17.9	75	
80	20.1	19.6	19.2	18.6	21.4	20.2	19.0	17.5	20.4	19.0	17.8	16.1	16.1	80	
85	18.7	18.3	17.9	17.4	19.2	18.2	17.2	15.8	18.2	17.0	16.0	14.4	14.4	85	
90	17.4	17.1	16.8	16.2	17.3	16.4	15.5	14.3	16.3	15.3	14.4	13.0	13.0	90	
95	16.3	16.0	15.7	14.9	15.6	14.8	14.1	13.0	14.6	13.7	12.9	11.7	11.7	95	
100	15.2	15.0	14.5	13.7	14.1	13.4	12.8	11.8	13.1	12.3	11.6	10.5	10.5	100	
105	14.3	13.8	13.4	12.7	12.8	12.2	11.6	10.8	11.8	11.1	10.4	9.5	9.5	105	
110	13.2	12.7	12.3	11.8	11.6	11.1	10.6	9.8	10.6	9.9	9.3	8.5	8.5	110	
115	12.1	11.8	11.5	11.0	10.5	10.1	9.6	9.0	9.5	8.9	8.4	7.7	7.7	115	
120	-	-	-	-	9.5	9.2	8.8	8.2	8.5	8.0	7.5	6.7	6.7	120	
125	-	-	-	-	8.7	8.4	8.0	7.5	7.6	7.1	6.5	5.8	5.8	125	
130	-	-	-	-	7.9	7.7	7.4	7.0	6.6	6.1	5.7	5.0	5.0	130	
135	-	-	-	-	-	-	-	-	5.6	5.2	4.9	4.3	4.3	135	
140	-	-	-	-	-	-	-	-	4.8	4.5	4.1	3.7	3.7	140	
145	-	-	-	-	-	-	-	-	4.1	3.8	3.5	3.2	3.2	145	

Operation

MB

46,700 lb + 10,000 lb		19'1"				20 mph				360°				ASME B30.5	
42.1 ft		56.2 ft				70.3 ft									
0.5°		1.5°		2.5°		4°		0.5°		1.5°		2.5°		4°	
ft	1,000 lb													ft	
10	-	264.6	264.6	264.6	-	168.7	168.7	168.7	-	163.3	155.5	143.5	10		
12	-	241.2	241.2	239.8	-	168.7	168.7	168.7	-	149.9	146.3	135.8	12		
15	-	204.6	204.6	187.9	-	168.7	168.7	168.7	-	139.1	132.9	124.6	15		
20	-	146.2	136.0	122.8	-	140.6	128.0	112.3	-	119.1	114.7	103.7	20		
25	-	101.5	96.5	89.5	-	98.2	91.5	82.7	-	95.2	87.3	77.2	25		
30	-	76.5	73.7	69.8	-	74.1	70.0	64.4	-	72.0	67.1	60.5	30		
35	-	61.0	59.7	-	-	58.4	55.7	52.0	-	56.8	53.5	48.9	35		
40	-	-	-	-	-	47.6	45.8	43.2	-	46.2	43.8	40.5	40		
45	-	-	-	-	-	39.6	38.4	36.7	-	38.4	36.6	34.1	45		
50	-	-	-	-	-	-	-	-	-	32.4	31.0	29.2	50		
55	-	-	-	-	-	-	-	-	-	27.6	26.7	25.3	55		
60	-	-	-	-	-	-	-	-	-	23.9	23.2	22.2	60		

84.4 ft		98.5 ft				112.7 ft									
0.5°		1.5°		2.5°		4°		0.5°		1.5°		2.5°		4°	
ft	1,000 lb													ft	
12	-	126.1	117.0	106.2	-	-	-	-	-	-	-	-	12		
15	-	115.2	107.6	98.4	-	96.8	89.5	52.7	-	-	-	-	15		
20	-	99.6	94.0	87.0	-	85.1	79.5	52.7	-	65.2	65.2	43.9	20		
25	-	87.1	80.1	69.7	-	75.2	70.8	52.7	-	65.2	62.1	43.9	25		
30	-	69.7	67.0	59.5	-	65.6	59.3	51.4	-	60.3	56.6	43.9	30		
35	-	57.8	53.9	48.6	-	52.5	50.4	47.6	-	52.6	47.7	41.5	35		
40	-	47.4	44.5	40.6	-	47.8	44.6	40.1	-	42.7	39.7	34.8	40		
45	-	39.6	37.4	34.4	-	40.2	37.7	34.2	-	38.1	36.6	34.1	45		
50	-	33.6	31.9	29.6	-	34.3	32.3	29.6	-	34.9	32.7	29.7	50		
55	-	28.9	27.6	25.7	-	29.6	28.0	25.8	-	30.2	28.4	26.0	55		
60	-	25.0	24.0	22.5	-	25.7	24.4	22.6	-	26.4	24.9	22.9	60		
65	-	21.8	21.0	19.8	-	22.6	21.5	20.0	-	23.3	22.0	20.3	65		
70	-	19.2	18.6	17.6	-	19.9	19.0	17.8	-	20.6	19.6	18.1	70		
75	-	17.0	16.6	-	-	17.6	16.9	15.9	-	18.3	17.4	16.2	75		
80	-	-	-	-	-	15.7	15.1	14.3	-	16.3	15.6	14.6	80		
85	-	-	-	-	-	14.0	13.6	12.9	-	14.6	14.0	13.1	85		
90	-	-	-	-	-	12.7	12.4	11.9	-	13.1	12.6	11.9	90		
95	-	-	-	-	-	-	-	-	-	11.8	11.4	10.8	95		
100	-	-	-	-	-	-	-	-	-	10.7	10.3	9.8	100		
105	-	-	-	-	-	-	-	-	-	9.8	9.5	9.2	105		

Operation

MB

46,700 lb + 10,000 lb		19'1"				20 mph				360°				ASME B30.5	
126.8 ft		140.9 ft				155.0 ft									
0.5°		1.5°		2.5°		4°		0.5°		1.5°		2.5°		4°	
ft	1,000 lb													ft	
20	-	51.5	47.7	36.6	-	-	-	-	-	-	-	-	-	-	20
25	-	59.0	54.7	36.6	-	49.5	47.3	28.4	-	-	-	-	-	-	25
30	-	54.0	50.3	36.6	-	48.0	44.5	28.4	-	39.0	36.9	24.9	-	-	30
35	-	49.3	46.3	36.6	-	44.6	41.5	28.4	-	37.8	35.2	24.9	-	-	35
40	-	43.3	39.4	34.3	-	41.2	38.6	28.4	-	35.7	33.5	24.9	-	-	40
45	-	36.1	33.0	29.0	-	36.5	33.2	28.4	-	33.7	31.7	24.9	-	-	45
50	-	31.3	30.0	28.2	-	32.2	30.4	26.9	-	31.7	28.9	24.9	-	-	50
55	-	29.1	28.0	25.8	-	28.6	26.4	23.5	-	27.3	25.0	21.9	-	-	55
60	-	26.7	25.1	22.8	-	24.9	23.1	20.6	-	23.7	21.7	19.1	-	-	60
65	-	23.6	22.2	20.3	-	21.8	20.3	18.2	-	20.6	19.0	16.8	-	-	65
70	-	20.9	19.8	18.1	-	19.2	17.9	16.1	-	18.1	16.7	14.7	-	-	70
75	-	18.7	17.7	16.2	-	17.0	15.9	14.3	-	15.9	14.6	13.0	-	-	75
80	-	16.7	15.9	14.6	-	15.0	14.1	12.7	-	13.9	12.9	11.4	-	-	80
85	-	15.0	14.2	13.2	-	13.3	12.5	11.3	-	12.3	11.3	10.1	-	-	85
90	-	13.5	12.9	11.9	-	11.9	11.1	10.1	-	10.8	10.0	8.8	-	-	90
95	-	12.2	11.6	10.8	-	10.5	9.9	9.0	-	9.5	8.8	7.7	-	-	95
100	-	11.0	10.5	9.8	-	9.4	8.8	8.0	-	8.3	7.7	6.6	-	-	100
105	-	9.9	9.5	9.0	-	8.3	7.8	7.1	-	7.2	6.5	5.5	-	-	105
110	-	9.0	8.7	8.2	-	7.4	6.9	6.2	-	6.0	5.4	4.5	-	-	110
115	-	8.2	7.9	7.5	-	6.4	6.0	5.3	-	5.0	4.4	3.6	-	-	115
120	-	-	-	-	-	5.5	5.1	4.5	-	4.0	3.5	2.8	-	-	120
125	-	-	-	-	-	4.7	4.4	3.9	-	3.1	2.7	*	-	-	125
130	-	-	-	-	-	4.0	3.7	3.4	-	2.4	*	*	-	-	130
135	-	-	-	-	-	-	-	-	-	*	*	*	-	-	135
140	-	-	-	-	-	-	-	-	-	*	*	*	-	-	140
145	-	-	-	-	-	-	-	-	-	*	*	*	-	-	145

An asterisk (*) on the chart indicates positions without rated loads. These areas are susceptible to instability in either the forward or backward direction. Even without a load, the boom should not be positioned in these configurations of the load chart to avoid tipping.

Operation

MB

23,300 lb + 10,000 lb		19'1"				20 mph				360°				ASME B30.5	
42.1 ft		56.2 ft				70.3 ft									
0.5°		1.5°		2.5°		4°		0.5°		1.5°		2.5°		4°	
ft	1,000 lb													ft	
10	-	264.6	264.6	-	-	168.7	168.7	-	-	163.3	155.5	-	-	10	
12	-	235.0	235.0	-	-	168.7	168.7	-	-	149.9	146.3	-	-	12	
15	-	184.7	178.5	-	-	168.7	164.0	-	-	139.1	132.9	-	-	15	
20	-	116.8	108.5	-	-	112.2	101.9	-	-	108.0	96.2	-	-	20	
25	-	80.3	76.1	-	-	77.5	72.1	-	-	75.1	68.6	-	-	25	
30	-	59.8	57.5	-	-	57.8	54.5	-	-	56.1	52.0	-	-	30	
35	-	47.1	46.1	-	-	45.0	42.8	-	-	43.7	40.9	-	-	35	
40	-	-	-	-	-	36.1	34.7	-	-	35.0	33.0	-	-	40	
45	-	-	-	-	-	29.7	28.7	-	-	28.6	27.1	-	-	45	
50	-	-	-	-	-	-	-	-	-	23.7	22.6	-	-	50	
55	-	-	-	-	-	-	-	-	-	19.8	19.0	-	-	55	
60	-	-	-	-	-	-	-	-	-	16.7	16.2	-	-	60	

84.4 ft		98.5 ft				112.7 ft									
0.5°		1.5°		2.5°		4°		0.5°		1.5°		2.5°		4°	
ft	1,000 lb													ft	
12	-	126.1	117.0	-	-	-	-	-	-	-	-	-	-	12	
15	-	115.2	107.6	-	-	96.8	89.5	-	-	-	-	-	-	15	
20	-	99.6	87.2	-	-	85.1	79.5	-	-	65.2	65.2	-	-	20	
25	-	69.7	68.2	-	-	67.6	61.1	-	-	65.2	59.7	-	-	25	
30	-	57.1	52.3	-	-	57.2	51.9	-	-	51.3	47.1	-	-	30	
35	-	44.9	41.6	-	-	45.3	41.6	-	-	45.3	41.7	-	-	35	
40	-	36.3	34.0	-	-	36.9	34.2	-	-	37.5	34.5	-	-	40	
45	-	29.9	28.2	-	-	30.6	28.5	-	-	31.3	29.0	-	-	45	
50	-	25.0	23.7	-	-	25.8	24.2	-	-	26.5	24.7	-	-	50	
55	-	21.2	20.1	-	-	21.9	20.6	-	-	22.7	21.2	-	-	55	
60	-	18.0	17.2	-	-	18.8	17.7	-	-	19.6	18.3	-	-	60	
65	-	15.4	14.7	-	-	16.2	15.3	-	-	17.0	15.9	-	-	65	
70	-	13.2	12.7	-	-	14.0	13.3	-	-	14.7	13.9	-	-	70	
75	-	11.5	11.1	-	-	12.2	11.6	-	-	12.9	12.2	-	-	75	
80	-	-	-	-	-	10.6	10.1	-	-	11.3	10.7	-	-	80	
85	-	-	-	-	-	9.3	8.9	-	-	9.9	9.4	-	-	85	
90	-	-	-	-	-	8.2	7.9	-	-	8.7	8.2	-	-	90	
95	-	-	-	-	-	-	-	-	-	7.6	7.2	-	-	95	
100	-	-	-	-	-	-	-	-	-	6.7	6.3	-	-	100	
105	-	-	-	-	-	-	-	-	-	5.8	5.6	-	-	105	

Operation

MB

23,300 lb + 10,000 lb		19'1"				20 mph				360°				ASME B30.5
126.8 ft		140.9 ft				155.0 ft								
ft	0.5°	1.5°	2.5°	4°	0.5°	1.5°	2.5°	4°	0.5°	1.5°	2.5°	4°	ft	
1,000 lb														
20	-	51.5	47.7	-	-	-	-	-	-	-	-	-	20	
25	-	59.0	54.7	-	-	49.5	47.3	-	-	-	-	-	25	
30	-	51.7	45.6	-	-	48.0	44.5	-	-	39.0	36.9	-	30	
35	-	40.6	37.6	-	-	40.8	37.1	-	-	37.8	35.2	-	35	
40	-	36.6	34.3	-	-	35.4	31.9	-	-	33.4	29.8	-	40	
45	-	31.5	29.0	-	-	29.4	26.7	-	-	28.0	25.1	-	45	
50	-	26.8	24.8	-	-	24.8	22.7	-	-	23.6	21.3	-	50	
55	-	23.0	21.4	-	-	21.1	19.4	-	-	20.0	18.1	-	55	
60	-	19.9	18.5	-	-	18.1	16.6	-	-	17.0	15.4	-	60	
65	-	17.3	16.2	-	-	15.6	14.4	-	-	14.5	13.1	-	65	
70	-	15.1	14.2	-	-	13.4	12.4	-	-	12.4	11.2	-	70	
75	-	13.3	12.5	-	-	11.6	10.7	-	-	10.6	9.6	-	75	
80	-	11.7	11.0	-	-	10.1	9.3	-	-	9.0	8.1	-	80	
85	-	10.3	9.7	-	-	8.7	8.0	-	-	7.6	6.7	-	85	
90	-	9.1	8.5	-	-	7.5	6.8	-	-	6.2	5.3	-	90	
95	-	8.0	7.5	-	-	6.2	5.6	-	-	4.8	4.1	-	95	
100	-	7.0	6.6	-	-	5.1	4.5	-	-	*	*	-	100	
105	-	6.1	5.7	-	-	4.0	3.5	-	-	*	*	-	105	
110	-	5.2	4.9	-	-	3.1	2.7	-	-	*	*	-	110	
115	-	4.5	4.2	-	-	2.3	*	-	-	*	*	-	115	
120	-	-	-	-	-	*	*	-	-	*	*	-	120	
125	-	-	-	-	-	*	*	-	-	*	*	-	125	
130	-	-	-	-	-	*	*	-	-	*	*	-	130	
135	-	-	-	-	-	-	-	-	-	*	*	-	135	
140	-	-	-	-	-	-	-	-	-	*	*	-	140	
145	-	-	-	-	-	-	-	-	-	*	*	-	145	

An asterisk (*) on the chart indicates positions without rated loads. These areas are susceptible to instability in either the forward or backward direction. Even without a load, the boom should not be positioned in these configurations of the load chart to avoid tipping.

Operation

MB

0 lb + 10,000 lb		19'1"				20 mph				360°				ASME B30.5	
42.1 ft		56.2 ft				70.3 ft									
0.5°		1.5°		2.5°		4°		0.5°		1.5°		2.5°		4°	
ft	1,000 lb													ft	
10	-	252.9	252.9	-	-	168.7	168.7	-	-	163.3	155.5	-	-	10	
12	-	208.0	208.0	-	-	168.7	168.7	-	-	149.9	146.3	-	-	12	
15	-	149.6	132.8	-	-	141.2	121.7	-	-	133.6	112.3	-	-	15	
20	-	85.6	79.3	-	-	82.2	74.3	-	-	78.9	69.9	-	-	20	
25	-	57.8	54.5	-	-	55.7	51.5	-	-	53.8	48.8	-	-	25	
30	-	42.1	40.3	-	-	40.6	38.0	-	-	39.3	36.1	-	-	30	
35	-	32.4	31.6	-	-	30.8	29.1	-	-	29.8	27.6	-	-	35	
40	-	-	-	-	-	24.1	22.9	-	-	23.1	21.6	-	-	40	
45	-	-	-	-	-	19.1	18.3	-	-	18.2	17.1	-	-	45	
50	-	-	-	-	-	-	-	-	-	14.5	13.6	-	-	50	
55	-	-	-	-	-	-	-	-	-	11.6	10.9	-	-	55	
60	-	-	-	-	-	-	-	-	-	9.2	8.8	-	-	60	

84.4 ft		98.5 ft				112.7 ft									
0.5°		1.5°		2.5°		4°		0.5°		1.5°		2.5°		4°	
ft	1,000 lb													ft	
12	-	126.1	117.0	-	-	-	-	-	-	-	-	-	-	12	
15	-	115.2	97.5	-	-	96.8	87.9	-	-	-	-	-	-	15	
20	-	71.8	68.9	-	-	68.8	67.2	-	-	65.2	56.7	-	-	20	
25	-	54.8	49.1	-	-	54.9	48.5	-	-	54.9	48.1	-	-	25	
30	-	40.5	36.9	-	-	41.0	36.9	-	-	41.5	37.0	-	-	30	
35	-	31.2	28.7	-	-	31.9	29.0	-	-	32.5	29.3	-	-	35	
40	-	24.6	22.8	-	-	25.4	23.3	-	-	26.1	23.8	-	-	40	
45	-	19.7	18.3	-	-	20.6	19.0	-	-	21.4	19.6	-	-	45	
50	-	16.0	14.9	-	-	16.8	15.6	-	-	17.7	16.2	-	-	50	
55	-	13.0	12.2	-	-	13.9	12.9	-	-	14.7	13.6	-	-	55	
60	-	10.6	9.9	-	-	11.5	10.6	-	-	12.3	11.4	-	-	60	
65	-	8.6	8.1	-	-	9.5	8.8	-	-	10.3	9.5	-	-	65	
70	-	6.9	6.3	-	-	7.8	7.3	-	-	8.6	8.0	-	-	70	
75	-	5.2	4.9	-	-	6.3	5.7	-	-	7.2	6.6	-	-	75	
80	-	-	-	-	-	4.8	4.4	-	-	5.8	5.2	-	-	80	
85	-	-	-	-	-	3.6	3.2	-	-	4.5	4.0	-	-	85	
90	-	-	-	-	-	2.6	2.4	-	-	3.4	3.0	-	-	90	
95	-	-	-	-	-	-	-	-	-	2.4	*	-	-	95	
100	-	-	-	-	-	-	-	-	-	*	*	-	-	100	
105	-	-	-	-	-	-	-	-	-	*	*	-	-	105	

An asterisk (*) on the chart indicates positions without rated loads. These areas are susceptible to instability in either the forward or backward direction. Even without a load, the boom should not be positioned in these configurations of the load chart to avoid tipping.

Operation

0 lb + 10,000 lb		19'1"				20 mph				360°				ASME B30.5	
126.8 ft		140.9 ft				155.0 ft									
0.5°		1.5°		2.5°		4°		0.5°		1.5°		2.5°		4°	
ft	1,000 lb													ft	
20	-	51.5	47.7	-	-	-	-	-	-	-	-	-	-	-	20
25	-	47.3	44.1	-	-	45.4	41.2	-	-	-	-	-	-	-	25
30	-	41.3	36.6	-	-	37.1	32.5	-	-	33.8	29.2	-	-	-	30
35	-	32.6	29.2	-	-	29.6	26.1	-	-	26.8	23.3	-	-	-	35
40	-	26.4	23.8	-	-	24.0	21.3	-	-	21.6	18.8	-	-	-	40
45	-	21.7	19.7	-	-	19.6	17.5	-	-	17.4	15.3	-	-	-	45
50	-	18.0	16.4	-	-	16.2	14.4	-	-	14.2	12.4	-	-	-	50
55	-	15.1	13.8	-	-	13.3	11.9	-	-	11.5	10.0	-	-	-	55
60	-	12.7	11.7	-	-	11.0	9.8	-	-	9.2	8.0	-	-	-	60
65	-	10.8	9.9	-	-	9.0	8.0	-	-	7.3	*	-	-	-	65
70	-	9.1	8.3	-	-	7.3	6.4	-	-	*	*	-	-	-	70
75	-	7.7	7.0	-	-	5.8	4.9	-	-	*	*	-	-	-	75
80	-	6.4	5.7	-	-	*	*	-	-	*	*	-	-	-	80
85	-	5.1	4.5	-	-	*	*	-	-	*	*	-	-	-	85
90	-	4.0	3.5	-	-	*	*	-	-	*	*	-	-	-	90
95	-	3.0	2.5	-	-	*	*	-	-	*	*	-	-	-	95
100	-	*	*	-	-	*	*	-	-	*	*	-	-	-	100
105	-	*	*	-	-	*	*	-	-	*	*	-	-	-	105
110	-	*	*	-	-	*	*	-	-	*	*	-	-	-	110
115	-	*	*	-	-	*	*	-	-	*	*	-	-	-	115
120	-	-	-	-	-	*	*	-	-	*	*	-	-	-	120
125	-	-	-	-	-	*	*	-	-	*	*	-	-	-	125
130	-	-	-	-	-	*	*	-	-	*	*	-	-	-	130
135	-	-	-	-	-	-	-	-	-	*	*	-	-	-	135
140	-	-	-	-	-	-	-	-	-	*	*	-	-	-	140
145	-	-	-	-	-	-	-	-	-	*	*	-	-	-	145

An asterisk (*) on the chart indicates positions without rated loads. These areas are susceptible to instability in either the forward or backward direction. Even without a load, the boom should not be positioned in these configurations of the load chart to avoid tipping.

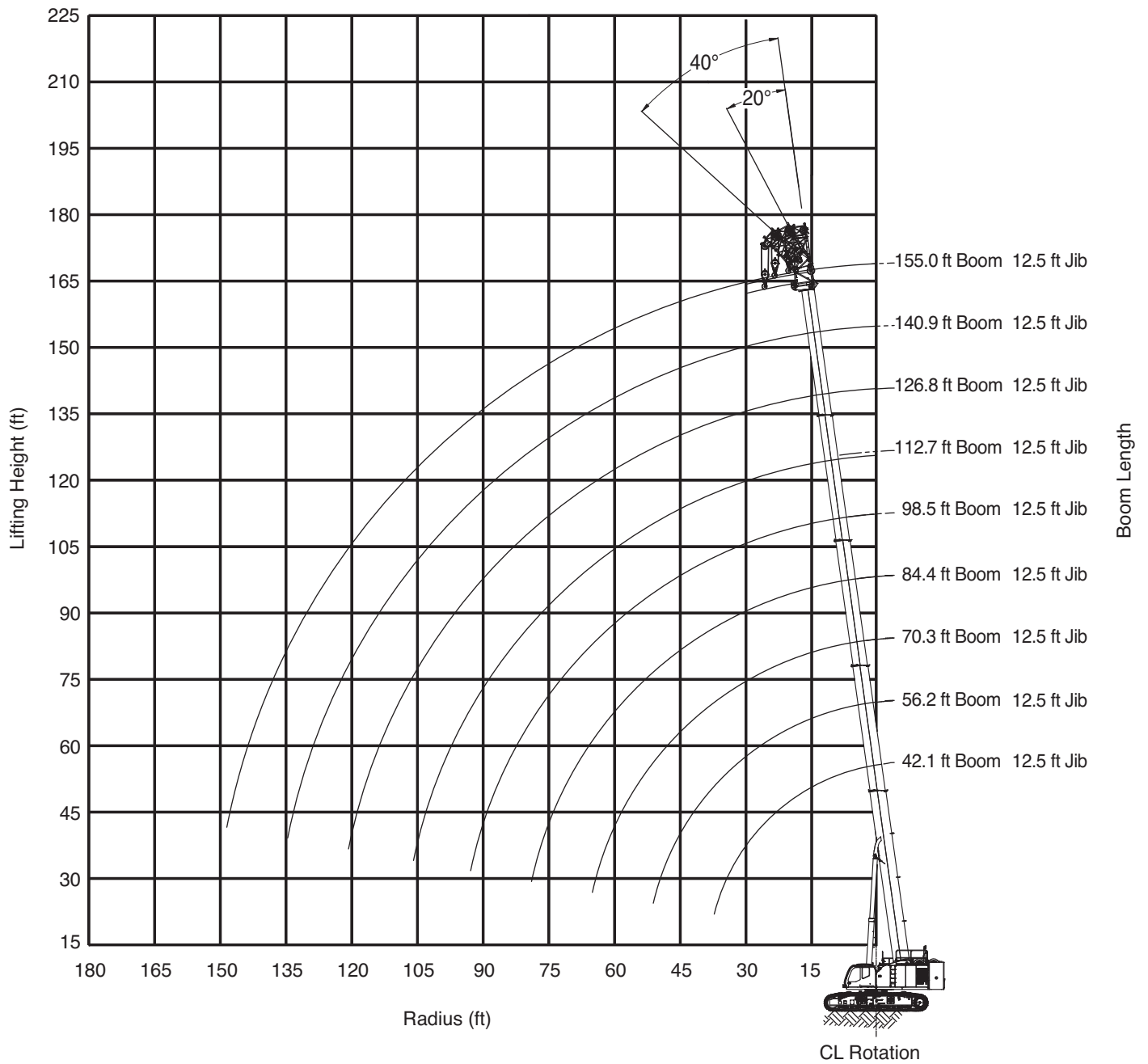

Operation

Jib assembly

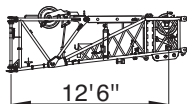

Tracks fully extended – 360° – Up to 0.5° slope – Heavy lift jib

70,000 lb +		20,000 lb		19'1"			0.5°			12.5 ft			20 mph			360°			ASME B30.5				
42.1 ft		112.7 ft			126.8 ft			140.9 ft			155.0 ft												
0°		20°		40°		0°		20°		40°		0°		20°		40°		0°		20°		40°	
1,000 lb																							
ft																							
10	88.2	72.1	-	-	-	-	-	-	-	-	-	-	-	-	-	-	-	-	-	-	-	-	10
12	88.2	72.0	55.6	-	-	-	-	-	-	-	-	-	-	-	-	-	-	-	-	-	-	-	12
14	88.2	68.3	54.9	-	-	-	-	-	-	-	-	-	-	-	-	-	-	-	-	-	-	-	14
16	88.2	64.9	53.1	-	-	-	-	-	-	-	-	-	-	-	-	-	-	-	-	-	-	-	16
18	83.0	61.9	51.4	-	-	-	-	-	-	-	-	-	-	-	-	-	-	-	-	-	-	-	18
20	77.8	59.3	49.9	-	-	-	-	-	-	-	-	-	-	-	-	-	-	-	-	-	-	-	20
22	73.2	56.9	48.5	-	-	-	-	-	-	-	-	-	-	-	-	-	-	-	-	-	-	-	22
24	69.1	54.7	47.3	-	34.9	-	-	-	-	-	-	-	-	-	-	-	-	-	-	-	-	-	24
26	65.6	52.8	46.2	37.3	34.9	31.3	-	-	-	-	-	-	-	-	-	-	-	-	-	-	-	-	26
28	62.4	51.1	45.3	36.5	34.1	31.3	31.9	29.4	-	-	-	-	-	-	-	-	-	-	-	-	-	-	28
30	59.5	49.5	44.4	36.4	33.0	30.6	30.8	29.4	26.8	-	27.4	-	-	-	-	-	-	-	-	-	-	-	30
35	53.4	46.2	42.9	33.5	30.6	28.6	29.8	27.6	25.9	27.5	26.8	24.2	-	24.4	-	-	-	-	-	-	-	-	35
40	48.8	43.8	-	31.1	28.7	26.9	27.6	25.7	24.3	26.9	25.0	23.7	24.5	24.1	21.9	-	-	-	-	-	-	-	40
45	45.4	42.9	-	29.0	26.9	25.4	25.6	24.1	22.9	25.1	23.5	22.3	24.1	22.6	21.5	-	-	-	-	-	-	-	45
50	-	-	-	26.7	25.4	24.1	23.6	22.7	21.6	23.5	22.1	21.1	22.7	21.4	20.4	-	-	-	-	-	-	-	50
55	-	-	-	24.7	24.1	23.0	21.8	21.4	20.5	21.9	21.0	20.1	21.5	20.3	19.4	-	-	-	-	-	-	-	55
60	-	-	-	22.9	22.6	22.0	20.2	20.1	19.5	20.4	19.9	19.1	20.2	19.3	18.5	-	-	-	-	-	-	-	60
65	-	-	-	21.3	21.1	20.9	18.8	18.7	18.6	19.1	18.9	18.3	18.9	18.4	17.7	-	-	-	-	-	-	-	65
70	-	-	-	19.9	19.7	19.6	17.5	17.4	17.4	17.9	17.7	17.5	17.8	17.6	17.0	-	-	-	-	-	-	-	70
75	-	-	-	18.6	18.4	18.4	16.4	16.3	16.2	16.8	16.7	16.6	16.8	16.6	16.3	-	-	-	-	-	-	-	75
80	-	-	-	17.4	17.3	17.2	15.3	15.3	15.2	15.8	15.7	15.7	15.9	15.7	15.7	-	-	-	-	-	-	-	80
85	-	-	-	16.4	16.3	16.2	14.4	14.3	14.3	14.9	14.8	14.7	15.0	14.9	14.8	-	-	-	-	-	-	-	85
90	-	-	-	15.4	15.3	15.3	13.5	13.5	13.4	14.1	14.0	14.0	14.0	14.1	14.1	-	-	-	-	-	-	-	90
100	-	-	-	13.1	13.2	-	11.6	11.7	11.8	12.2	12.5	12.5	10.9	11.2	11.4	-	-	-	-	-	-	-	100
110	-	-	-	10.8	10.8	-	9.9	9.9	-	9.6	9.8	9.9	8.2	8.5	8.7	-	-	-	-	-	-	-	110
120	-	-	-	-	-	-	8.4	8.4	-	7.3	7.5	-	5.6	5.9	6.1	-	-	-	-	-	-	-	120
130	-	-	-	-	-	-	7.2	-	-	5.2	5.4	-	3.5	3.8	-	-	-	-	-	-	-	-	130
140	-	-	-	-	-	-	-	-	-	3.5	3.6	-	1.8	1.9	-	-	-	-	-	-	-	-	140
	6	6	6	3	3	3	2	2	2	2	2	2	2	2	2	2	2	2	2	2	2		

Load chart data is for reference, load charts supplied in the crane cab shall be used for lift planning.

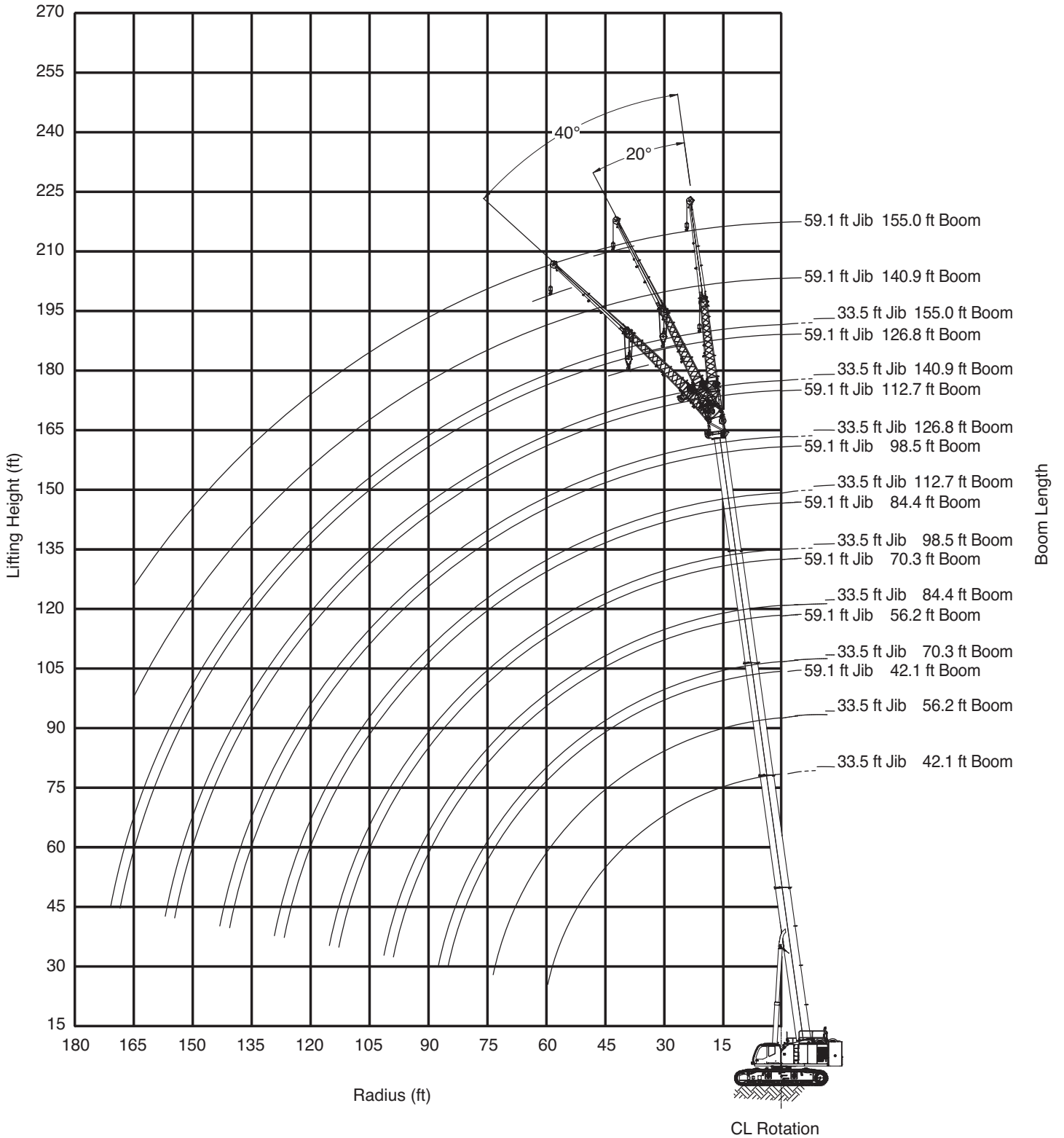

Operation

Jib assembly

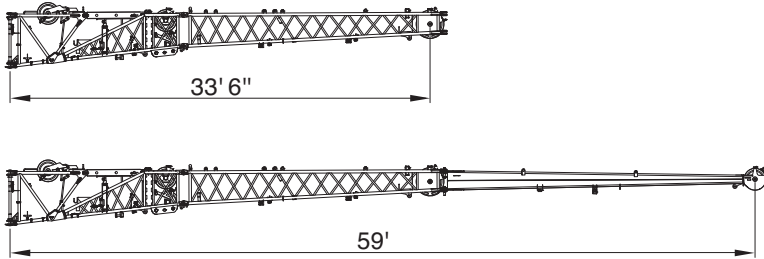

Tracks fully extended – 360° – Up to 0.5° slope – Folding jib

70,000 lb + 20,000 lb		19'1"		0.5°		33.5 ft		20 mph		360°		ASME B30.5					
42.1 ft			112.7 ft			126.8 ft			140.9 ft			155.0 ft					
0°		20°		40°		0°		20°		40°		0°		20°		40°	
1,000 lb																	
ft																	ft
10	33.1	-	-	-	-	-	-	-	-	-	-	-	-	-	-	-	10
12	33.1	-	-	-	-	-	-	-	-	-	-	-	-	-	-	-	12
14	33.1	-	-	-	-	-	-	-	-	-	-	-	-	-	-	-	14
16	33.1	-	-	-	-	-	-	-	-	-	-	-	-	-	-	-	16
18	33.1	32.4	-	-	-	-	-	-	-	-	-	-	-	-	-	-	18
20	33.1	32.4	-	-	-	-	-	-	-	-	-	-	-	-	-	-	20
22	33.1	30.8	-	-	-	-	-	-	-	-	-	-	-	-	-	-	22
24	33.1	29.3	-	29.5	-	-	-	-	-	-	-	-	-	-	-	-	24
26	33.1	27.9	20.5	29.5	-	-	24.5	-	-	-	-	-	-	-	-	-	26
28	33.1	26.7	20.5	29.5	-	-	24.5	-	-	-	-	-	-	-	-	-	28
30	33.1	25.6	20.4	29.5	-	-	24.5	-	-	23.1	-	-	-	-	-	-	30
35	30.2	23.1	19.0	29.3	22.6	-	24.5	-	-	23.1	-	-	19.0	-	-	-	35
40	26.6	21.1	17.9	26.9	22.0	-	22.7	19.2	-	23.1	-	-	19.0	-	-	-	40
45	23.7	19.5	16.9	24.8	20.6	17.6	21.1	18.8	-	21.9	17.7	-	19.0	-	-	-	45
50	21.3	18.1	16.1	23.1	19.5	17.2	19.8	17.7	15.4	20.4	17.5	15.1	19.0	16.9	-	-	50
55	19.4	17.0	15.5	21.6	18.4	16.4	18.6	16.8	15.1	19.2	16.5	14.8	19.0	16.7	14.7	-	55
60	17.8	16.1	15.2	20.3	17.5	15.7	17.5	15.9	14.4	18.1	15.7	14.2	18.1	15.9	14.6	-	60
65	16.5	15.5	-	19.2	16.6	15.1	16.6	15.1	13.8	17.1	14.9	13.6	17.2	15.2	13.9	-	65
70	-	-	-	18.1	15.9	14.5	15.7	14.4	13.2	16.2	14.2	13.0	16.3	14.5	13.4	-	70
75	-	-	-	17.2	15.2	13.9	14.8	13.7	12.7	15.4	13.6	12.5	15.5	13.9	12.9	-	75
80	-	-	-	16.2	14.6	13.4	13.9	13.2	12.2	14.6	13.1	12.1	14.6	13.4	12.4	-	80
85	-	-	-	15.3	14.0	13.0	13.1	12.6	11.8	13.8	12.6	11.7	13.8	12.9	11.9	-	85
90	-	-	-	14.4	13.5	12.6	12.3	12.1	11.4	13.1	12.1	11.3	13.1	12.4	11.5	-	90
100	-	-	-	12.8	12.6	11.9	11.0	11.3	10.7	11.7	11.3	10.6	11.9	11.6	10.8	-	100
110	-	-	-	11.0	11.2	11.4	9.5	10.1	10.1	10.6	10.5	10.0	9.8	10.6	10.2	-	110
120	-	-	-	9.6	9.8	-	8.2	8.7	9.0	8.7	9.5	9.5	7.5	8.6	9.2	-	120
130	-	-	-	8.4	8.5	-	7.1	7.5	-	6.8	7.6	8.0	5.4	6.4	7.1	-	130
140	-	-	-	-	-	-	6.2	6.5	-	5.0	5.7	-	3.6	4.5	5.0	-	140
150	-	-	-	-	-	-	-	-	-	3.6	4.1	-	2.1	2.8	3.2	-	150
160	-	-	-	-	-	-	-	-	-	1.9	-	-	-	-	-	-	160
	2	2	2	2	2	2	2	2	2	2	2	2	1	1	1		

Load chart data is for reference, load charts supplied in the crane cab shall be used for lift planning.

Operation



Tracks fully extended – 360° – Up to 0.5° slope – Folding jib

70,000 lb + 20,000 lb 19'1" 0.5° 59.1 ft 20 mph 360° ASME B30.5																		
42.1 ft 112.7 ft 126.8 ft 140.9 ft 155.0 ft	0°			20°			40°			0°			20°			40°		
	ft	1,000 lb															ft	
14	15.0	-	-	-	-	-	-	-	-	-	-	-	-	-	-	-	-	14
16	15.0	-	-	-	-	-	-	-	-	-	-	-	-	-	-	-	-	16
18	15.0	-	-	-	-	-	-	-	-	-	-	-	-	-	-	-	-	18
20	15.0	-	-	-	-	-	-	-	-	-	-	-	-	-	-	-	-	20
22	15.0	-	-	-	-	-	-	-	-	-	-	-	-	-	-	-	-	22
24	15.0	-	-	-	-	-	-	-	-	-	-	-	-	-	-	-	-	24
26	15.0	-	-	-	-	-	-	-	-	-	-	-	-	-	-	-	-	26
28	15.0	-	-	-	-	-	-	-	-	-	-	-	-	-	-	-	-	28
30	15.0	-	-	11.9	-	-	-	-	-	-	-	-	-	-	-	-	-	30
35	15.0	11.3	-	11.9	-	-	11.0	-	-	-	-	-	-	-	-	-	-	35
40	13.9	10.8	-	11.9	-	-	11.0	-	-	10.6	-	-	-	-	-	-	-	40
45	12.7	10.0	-	11.9	-	-	11.0	-	-	10.6	-	-	10.1	-	-	-	-	45
50	11.6	9.4	7.7	11.9	9.5	-	11.0	-	-	10.6	-	-	10.1	-	-	-	-	50
55	10.7	8.8	7.7	11.9	9.5	-	11.0	9.0	-	10.6	-	-	10.1	-	-	-	-	55
60	9.9	8.3	7.3	11.9	9.5	-	11.0	9.0	-	10.6	9.0	-	10.1	-	-	-	-	60
65	9.2	7.8	7.0	11.9	9.1	7.1	11.0	9.0	-	10.6	9.0	-	10.1	8.0	-	-	-	65
70	8.6	7.5	6.7	11.9	8.8	7.1	11.0	8.8	6.6	10.6	8.8	-	10.1	8.0	-	-	-	70
75	8.1	7.1	6.5	11.4	8.5	7.1	11.0	8.5	6.6	10.6	8.6	6.6	10.1	8.0	-	-	-	75
80	7.7	6.8	6.4	10.9	8.2	6.9	11.0	8.2	6.6	10.6	8.3	6.6	10.1	8.0	6.0	-	-	80
85	7.2	6.5	6.3	10.5	7.9	6.7	10.6	8.0	6.6	10.6	8.1	6.6	10.1	8.0	6.0	-	-	85
90	6.9	6.4	-	10.0	7.7	6.6	10.2	7.8	6.6	10.4	7.8	6.6	10.1	7.9	6.0	-	-	90
100	-	-	-	9.3	7.3	6.3	9.5	7.3	6.3	9.8	7.4	6.4	9.9	7.5	6.0	-	-	100
110	-	-	-	8.6	6.9	6.1	8.9	7.0	6.1	9.1	7.1	6.2	9.2	7.1	6.0	-	-	110
120	-	-	-	8.0	6.6	6.0	8.0	6.7	6.0	8.6	6.8	6.0	8.6	6.8	6.0	-	-	120
130	-	-	-	7.6	6.3	5.8	7.1	6.4	5.8	7.8	6.5	5.8	6.9	6.5	5.8	-	-	130
140	-	-	-	7.0	6.2	5.8	6.1	6.2	5.7	6.7	6.3	5.7	5.0	6.3	5.7	-	-	140
150	-	-	-	6.2	6.0	-	5.3	5.7	5.7	5.2	6.1	5.6	3.5	4.9	5.6	-	-	150
165	-	-	-	5.1	-	-	4.3	4.5	-	3.2	4.1	4.5	1.6	2.7	3.4	-	-	165
180	-	-	-	-	-	-	-	-	-	1.7	2.2	-	-	0.8	-	-	-	180
1	1	1	1	1	1	1	1	1	1	1	1	1	1	1	1	1	1	1

Load chart data is for reference, load charts supplied in the crane cab shall be used for lift planning.

Operation

Jib assembly

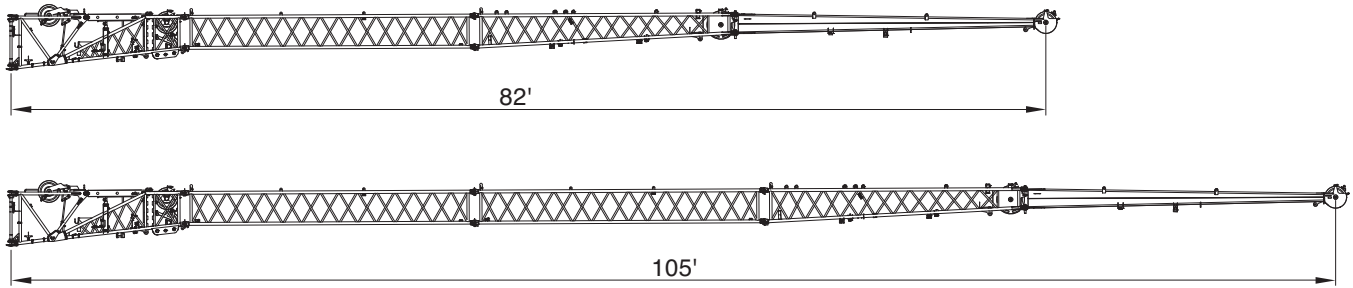

Tracks fully extended – 360° – Up to 0.5° slope – Folding jib

		70,000 lb + 20,000 lb			19'1"			0.5°			82.0 ft			20 mph			360°			ASME B30.5		
		42.1 ft			112.7 ft			126.8 ft			140.9 ft			155.0 ft								
		0°			20°			40°			0°			20°			40°					
ft		1,000 lb															ft					
18	11.2	-	-	-	-	-	-	-	-	-	-	-	-	-	-	-	-	-	-	-	18	
20	11.2	-	-	-	-	-	-	-	-	-	-	-	-	-	-	-	-	-	-	-	20	
22	11.2	-	-	-	-	-	-	-	-	-	-	-	-	-	-	-	-	-	-	-	22	
24	11.2	-	-	-	-	-	-	-	-	-	-	-	-	-	-	-	-	-	-	-	24	
26	11.2	-	-	-	-	-	-	-	-	-	-	-	-	-	-	-	-	-	-	-	26	
28	11.2	-	-	-	-	-	-	-	-	-	-	-	-	-	-	-	-	-	-	-	28	
30	11.2	-	-	-	-	-	-	-	-	-	-	-	-	-	-	-	-	-	-	-	30	
35	11.2	-	-	-	-	-	-	-	-	-	-	-	-	-	-	-	-	-	-	-	35	
40	11.2	-	-	-	8.2	-	-	-	-	-	-	-	-	-	-	-	-	-	-	-	40	
45	11.2	9.9	-	-	8.2	-	-	7.7	-	-	7.5	-	-	-	-	-	-	-	-	-	45	
50	11.2	9.3	-	-	8.2	-	-	7.7	-	-	7.5	-	-	7.1	-	-	-	-	-	-	50	
55	10.6	8.6	-	-	8.2	-	-	7.7	-	-	7.5	-	-	7.1	-	-	-	-	-	-	55	
60	9.7	7.9	-	-	8.2	-	-	7.7	-	-	7.5	-	-	7.1	-	-	-	-	-	-	60	
65	8.9	7.4	-	-	8.2	8.2	-	7.7	-	-	7.5	-	-	7.1	-	-	-	-	-	-	65	
70	8.2	6.9	6.0	-	8.2	8.2	-	7.7	7.7	-	7.5	-	-	7.1	-	-	-	-	-	-	70	
75	7.6	6.5	5.7	-	8.2	8.1	-	7.7	7.7	-	7.5	7.5	-	7.1	-	-	-	-	-	-	75	
80	7.1	6.1	5.4	-	8.2	7.7	-	7.7	7.7	-	7.5	7.5	-	7.1	7.1	-	-	-	-	-	80	
85	6.6	5.8	5.2	-	8.2	7.4	5.8	7.7	7.6	-	7.5	7.5	-	7.1	7.1	-	-	-	-	-	85	
90	6.2	5.5	5.0	-	8.2	7.1	5.6	7.7	7.3	5.6	7.5	7.4	-	7.1	7.1	-	-	-	-	-	90	
100	5.4	5.0	-	-	8.2	6.6	5.3	7.7	6.8	5.4	7.5	6.9	5.4	7.1	6.7	5.4	-	-	-	-	100	
110	4.9	4.6	-	-	8.0	6.1	5.0	7.3	6.3	5.1	7.3	6.4	5.2	7.1	6.2	5.2	-	-	-	-	110	
120	-	-	-	-	7.3	5.7	4.9	6.8	5.9	4.9	6.8	6.0	5.0	6.6	5.8	5.0	-	-	-	-	120	
130	-	-	-	-	6.7	5.4	4.7	6.0	5.6	4.7	6.3	5.6	4.8	6.2	5.5	4.9	-	-	-	-	130	
140	-	-	-	-	6.1	5.1	4.5	5.3	5.1	4.6	5.9	5.3	4.7	5.2	5.2	4.7	-	-	-	-	140	
150	-	-	-	-	5.7	4.9	4.4	4.7	4.7	4.5	5.2	5.0	4.5	3.7	4.9	4.6	-	-	-	-	150	
165	-	-	-	-	4.7	4.5	-	3.9	4.1	4.1	3.5	4.4	4.3	1.9	3.5	4.3	-	-	-	-	165	
180	-	-	-	-	-	-	-	3.1	3.4	-	2.0	3.0	-	-	1.7	2.6	-	-	-	-	180	
		1	1	1	1	1	1	1	1	1	1	1	1	1	1	1	1	1	1			

Load chart data is for reference, load charts supplied in the crane cab shall be used for lift planning.

Operation



Tracks fully extended – 360° – Up to 0.5° slope – Folding jib

70,000 lb + 20,000 lb 19'1" 0.5° 105.0 ft 20 mph 360° ASME B30.5																
	42.1 ft			112.7 ft			126.8 ft			140.9 ft			155.0 ft			
	0°	20°	40°	0°	20°	40°	0°	20°	40°	0°	20°	40°	0°	20°	40°	
ft	1,000 lb															ft
24	7.7	-	-	-	-	-	-	-	-	-	-	-	-	-	-	24
26	7.7	-	-	-	-	-	-	-	-	-	-	-	-	-	-	26
28	7.7	-	-	-	-	-	-	-	-	-	-	-	-	-	-	28
30	7.7	-	-	-	-	-	-	-	-	-	-	-	-	-	-	30
35	7.7	-	-	-	-	-	-	-	-	-	-	-	-	-	-	35
40	7.7	-	-	-	-	-	-	-	-	-	-	-	-	-	-	40
45	7.7	-	-	6.0	-	-	-	-	-	-	-	-	-	-	-	45
50	7.7	-	-	6.0	-	-	5.7	-	-	-	-	-	-	-	-	50
55	7.7	-	-	6.0	-	-	5.7	-	-	5.5	-	-	-	-	-	55
60	7.6	6.7	-	6.0	-	-	5.7	-	-	5.5	-	-	5.3	-	-	60
65	7.3	6.2	-	6.0	-	-	5.7	-	-	5.5	-	-	5.3	-	-	65
70	6.9	5.8	-	6.0	-	-	5.7	-	-	5.5	-	-	5.3	-	-	70
75	6.5	5.4	-	6.0	-	-	5.7	-	-	5.5	-	-	5.3	-	-	75
80	6.0	5.1	-	6.0	5.5	-	5.7	-	-	5.5	-	-	5.3	-	-	80
85	5.6	4.8	4.1	6.0	5.4	-	5.7	5.2	-	5.5	-	-	5.3	-	-	85
90	5.2	4.5	3.9	6.0	5.2	-	5.7	5.1	-	5.5	5.0	-	5.3	-	-	90
100	4.5	4.0	3.6	5.9	5.0	-	5.7	4.9	-	5.5	4.8	-	5.3	4.7	-	100
110	4.0	3.6	3.3	5.6	4.7	3.7	5.5	4.7	-	5.4	4.6	-	5.3	4.5	-	110
120	3.6	3.3	3.1	5.3	4.3	3.5	5.2	4.4	3.5	5.2	4.4	3.5	5.1	4.3	-	120
130	3.2	3.1	-	5.1	4.0	3.3	5.0	4.1	3.4	5.0	4.3	3.4	4.9	4.2	3.4	130
140	-	-	-	4.7	3.7	3.2	4.6	3.9	3.2	4.8	4.0	3.2	4.8	4.1	3.3	140
150	-	-	-	4.3	3.5	3.0	4.2	3.7	3.1	4.5	3.8	3.1	4.3	3.9	3.1	150
165	-	-	-	3.9	3.3	2.9	3.5	3.4	2.9	3.9	3.5	3.0	2.6	3.6	3.0	165
180	-	-	-	3.5	3.0	-	2.9	3.0	2.8	2.6	3.2	2.9	-	2.9	2.9	180
195	-	-	-	-	-	-	2.3	2.6	2.7	-	2.6	2.8	-	-	2.5	195
	1	1	1	1	1	1	1	1	1	1	1	1	1	1	1	

Load chart data is for reference, load charts supplied in the crane cab shall be used for lift planning.

Operation

WP

WP750 Work platform

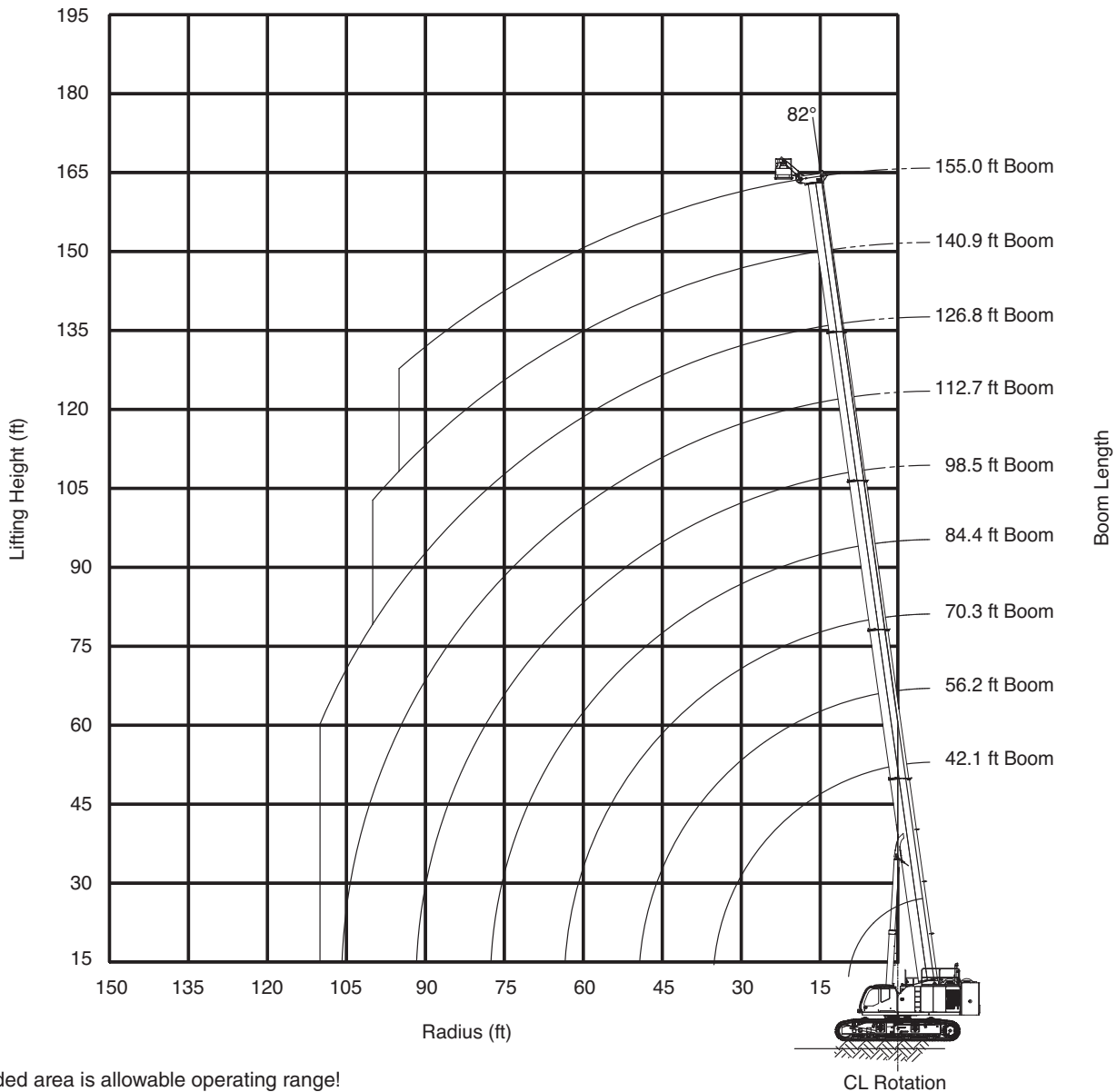

Shaded area is allowable operating range!

Limits of operation:

Max. load capacity = 750 lb · Max. radius when mounted on main boom = 110 ft · Max. occupancy = 2 persons

Notes:

1. It is permissible to leave the jibs stowed on the boom while operating with work platform mounted to the main boom.
2. The hook block(s) must be removed when using the work platform.

WARNING: Lifting a load during work platform operation is **not** allowed.

WARNING: Travelling the crane with person(s) in the work platform is **not** allowed.

WP750 Work platform

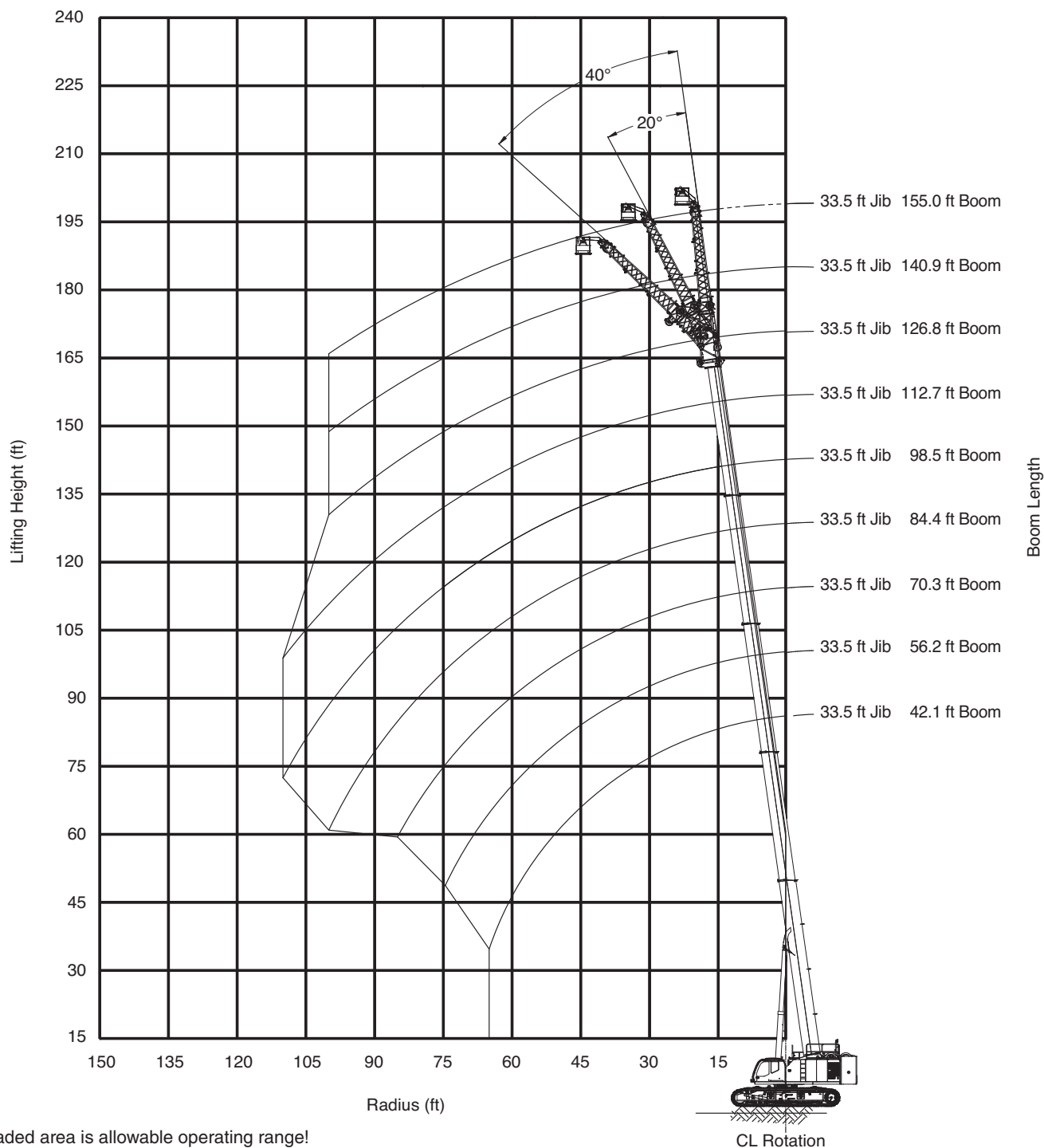

Shaded area is allowable operating range!

Limits of operation:

Max. load capacity = 750 lb · Max. radius when mounted on jib = 110 ft · Max. occupancy = 2 persons

Notes:

1. It is permissible to leave the jib section stowed on the boom while operating with work platform mounted to the 33.5 ft jib.
2. The hook block(s) must be removed when using the work platform.

WARNING: Lifting a load during work platform operation is **not** allowed.

WARNING: Travelling the crane with person(s) in the work platform is **not** allowed.

Notes to Lifting Capacity

Definitions and Explanations

- Load capacity values in these charts are stated in lb x 1000.
- All ratings are for 360° of rotation unless otherwise specified on the chart.
- Load radius is defined as the horizontal distance from the axis of rotation (with no load) to the center of the lifting device after load is applied in feet (ft).
- Boom height dimensions are measured from ground to center of lower boom head sheave in feet (ft).
- Boom angle / boom length relationships given are an approximation of the resulting load radius, which should be an accurate measurement.
- Boom angle is the included angle between the longitudinal axis of the boom base section and the horizontal axis, after lifting load. The boom angle before lifting should be slightly greater than desired to account for boom deflection.
- Boom positions without rated loads in the charts are prohibited. These areas are indicated by an “*” and are susceptible to instability either in the forward direction or the backwards direction.
- It is acceptable to telescope boom with a load within the limits of rated capacities. However, boom angle, system hydraulic pressure, and/or boom lubrication may affect operation.
- Deduct the weight of the hook block, hook/ball, slings, spreader bar, or other suspended equipment from the listed rated capacities. This includes lifting accessories stowed on the boom such as jib, extension, and auger.
- Unless otherwise noted, travelling in low speed is allowed for all rated loads- reduce travel speed to minimize dynamic effects on the crane from swinging load, side loading, etc.
- This crane as originally manufactured meets the requirements of ASME B30.5 2014. Structure and stability have been tested in accordance with SAE J1063 and SAE J765.

Note

Data published herein is intended as a guide only and shall not be construed to warrant applicability for lifting purposes. Crane operation is subject to the computer charts and operation manual both supplied with the crane.

TECHNICAL DESCRIPTION

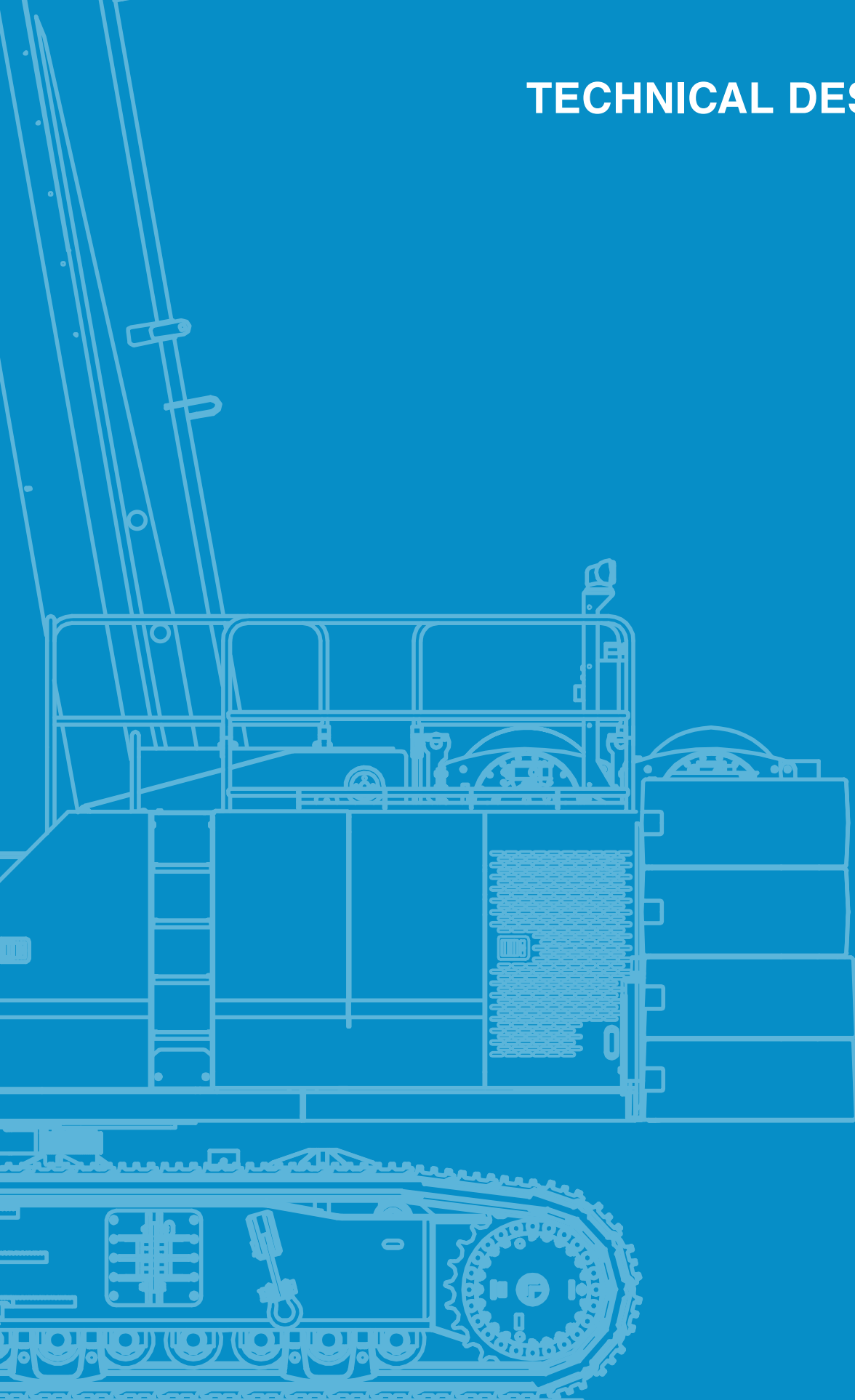

Technical Description

Crane specifications

Boom	<p>5-section full power telescoping boom with 2 extension modes. System consists of three double acting hydraulic cylinders with load holding valves and extension and retraction cables.</p> <p>Retracted length: 42' 1"</p> <p>Extended length: 155' 0" Extension time: 200 s</p> <p>Elevating angles: -2° to 82° Elevating time: 89 s</p> <p>Boom head: Eight, 21.4 inch diameter cast nylon sheaves on heavy-duty roller bearings (6 load bearing and 2 lead in sheaves). Designed for quick reeving of head and load block.</p>
Auxiliary boom head	<p>Quick reeve, single 21.4 inch diameter high-strength, cast nylon sheave mounted on a heavy-duty roller bearing. Allows single or 2 part reeving.</p>
Counterweight	<p>6 piece counterweight design. Three upper counterweight configurations.</p> <p>Configuration „A“ = 23,350 lb</p> <p>Configuration „B“ = 46,700 lb</p> <p>Configuration „C“ = 70,000 lb</p> <p>Two carbody counterweights, 10,000 lb each.</p>
Winches	<p>Planetary geared two-speed winch includes a hydraulic motor, multi-disc internal brake, counterbalance valve, grooved drum, cable follower, and 3rd wrap indicator. Drum rotation indicator is included (complete winch performance specs on page 20).</p> <p>Main winch:</p> <ul style="list-style-type: none">Rope diameter and length: 7/8" x 758 ftSingle line pull: 23,560 lb – first layerSingle line speed: 293 ft/min – 5th layer <p>Auxiliary winch:</p> <ul style="list-style-type: none">Rope diameter and length: 7/8" x 613 ftSingle line pull: 23,560 lb – first layerSingle line speed: 293 ft/min – 5th layer
Travel	<p>Each side frame contains a pilot controlled, two-speed track drive with hydraulic axial piston motor and parking brake. Travel system provides skid steering and counter rotation.</p> <p>Travel speed: Low: 0.5 mph · High: 1.4 mph</p> <p>Gradeability (unladen): 70%</p>
Swing	<p>Closed loop hydrostatic transmission with electronic displacement controlled piston pump. Operator selectable modes allow for either free swing with counter-swing or closed loop swing. Swing motor drives planetary gear reducer with a shaft mounted pinion, external gear shear ball slew bearing bolted to the superstructure and the carbody allows the superstructure to rotate 360°.</p> <p>Swing speed: 0 - 1.5 rpm.</p> <p>Swing parking brake: Spring applied failsafe brake with hydraulic release that is controlled from the operators cab.</p> <p>Swing service brake: Hydraulically applied, controlled through foot actuated pedal.</p> <p>House lock system: 4-position house lock (boom over front, rear or either side). Actuated from the operator's cab.</p>
Load moment indicator	<p>TADANO AML-C rated capacity limiter and anti-two block system:</p> <p>OPTI-WIDTH™ – OPTIMAL lifting performance at any track WIDTH.</p> <p>Control function shutdown. Audible and visual warnings.</p> <p>LCD screen provides a continuous display of working boom length, boom angle, working load radius, tip height, swing position, parts-of-line (operator set), machine track configuration, relative load moment, maximum permissible load and actual load.</p> <p>Anti-two block weight allows quick reeving of hook block.</p> <p>Operator configurable working range limits with automatic soft stop.</p>
Frame	<p>The frame is an all-steel, welded structure, precision machined to accept attachment of the boom and swing components.</p>
Operators cab	<p>Fully-enclosed, air conditioned all-steel modular cab with lockable sliding door, acoustical lining, anti-slip floor and tinted safety glass.</p> <p>Cab tilts 20°. Rear view, winch view, and right side view cameras are appropriately located as are three remote control work lights. Grab bars and steps are located for easy access to the cab. Defroster, heater, circulating fan. 2-speed windshield wiper, top glass wiper. Six-way adjustable fabric seat with headrest, seat belt. Dome light.</p> <p>Dry-chemical fire extinguisher. Four-way electronic armrest mounted joysticks control swing, main winch, auxiliary winch, boom extend, and boom hoist. Electronic foot pedals control the travel. Hydraulic brake pedal controls swing service brake function. Selectable modes for fine control and travel (using hand control for crane travel). Seat termination switch immediately disable all hydraulic functions as the operator rises from the seat. Functions can also be disabled by switch on console. Dash instrumentation: tachometer, hour meter, fuel gauge, and DEF level gauge. Indicators are provided for crane level, swing position, load moment, drum rotation, air filter restriction, engine oil temperature and pressure, hydraulic oil temperature and level, and hydraulic and air filter restriction, and low voltage.</p>

Technical Description

Crane specifications

Engine	Make/Model: Cummins QSL9 · Type: 6 cylinder, water cooled, 4 cycle · Aspiration: turbocharged and aftercooled · Max. output: 350 HP (261 kW)@2100 rpm · Max. torque: 1,201 lb-ft (1,628 Nm)@1500 rpm · Piston disp: 8.9 l · Emission Cert: U.S. EPA Tier 4f, Euromot Stage IV · Alternator: 70 amp. · Throttle control by: accelerator pedal, auto-idle, or adaptive throttle.
Electrical system	24 VDC.
Fuel system	Capacity: 125 gallons. Filtration: Inline fuel/water separator and engine mounted fuel filter.
Side frames	Two welded steel side frames are paired with a track group. The side frames extend and retract hydraulically and are controlled from the cab. Track rollers: Two top and fourteen bottom sealed rollers on each track frame Idler: Oil filled, self lubricating with nitrogen type tensioner. Track shoes: 36 inch, 3-bar semi grouser.
Hydraulic system	Hydraulic pumps: Two high pressure, variable axial piston pumps with load sense and power limiting control for crane functions. One axial piston pump for swing function. Directional valves: Multiple pressure and flow compensated valves with integrated relief valves controlled by electrical signals. Pump output: 222 gpm@2100 rpm engine speed. 5,000 psi maximum pressure. Reservoir: 366 gallons capacity, filler breather cap, sight gauge, cleanout, and sump drain. Filtration: Three 5 micron, full flow tank mounted return filters with electrical clogging indicator. 2 micron pilot oil in-line pressure filter. Diagnostic ports: Provided for system, load sense, and pilot pressure.

Optional equipment

Jibs	Heavy lift jib: Total length: 12.5 ft Max. lifting height: 166.5 ft Offset angles: 20° and 40° Main jib: Total length: 33.5 ft Max. lifting height: 187 ft Offset angles: 20° and 40° Fly jib: Total length: 59.1 ft Max. lifting height: 213 ft Offset angles: 20° and 40° Long jib: Total length: 105 ft Max. lifting height: 259 ft Offset angles: 20° and 40°
Hook blocks	130 ton quick reeve hook block – six, 18 inch steel sheaves, swivel hook and safety latch. 99 ton quick reeve hook block – five, 18 inch steel sheaves, swivel hook and safety latch. 70 ton quick reeve hook block – three, 18 inch steel sheaves, swivel hook and safety latch. 27 ton quick reeve hook block – one, 18 inch steel sheave, swivel hook and safety latch.
Overhaul ball	13.8 ton with swivel hook and safety latch.
360° house lock	Actuated from the operator's cab.
Track shoes	36 inch flat shoe.
Tool circuit	Provides 5 gpm and 10 gpm@2,500 psi through a 50 ft twin hose reel with quick disconnect fittings to operate open center tools.
High flow tool circuit	Provides 45 gpm@4800 psi.
Free fall hoists	Winches are available in controlled free fall configurations.
Cold weather packages	Cold weather options are available for operation to -40°C (consult factory for application support).
Work platform	Model WP750 – 36 in. x 72 in., all steel, welded, two person platform with maximum capacity of 750 lb.
Full function radio remote control package	
Boom mounted anemometer with cab display	
Automatic central lubrication system	

tac.sales@tadano.com
www.tadano.com

Tadano Ltd.

Kanda Square 18th Floor, 2-2-1 Kanda-Nishikicho, Chiyoda-ku, Tokyo 101-0054, Japan
Phone: +81-3-6811-7309 (International Division)

Tadano America Corporation

4242 West Greens Road, Houston, TX 77066
Phone: +1 (281) 869-00300 · Fax: +1 (281) 869-0040



Reaching new heights

