

# AA-14P

(NUL14W)

## ARTICULATED BOOM

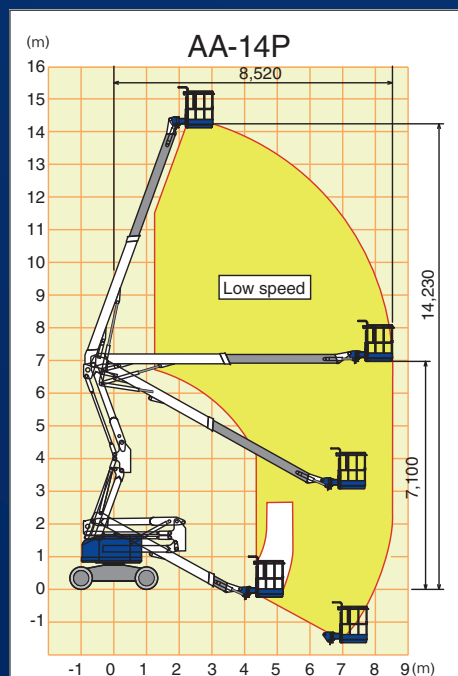
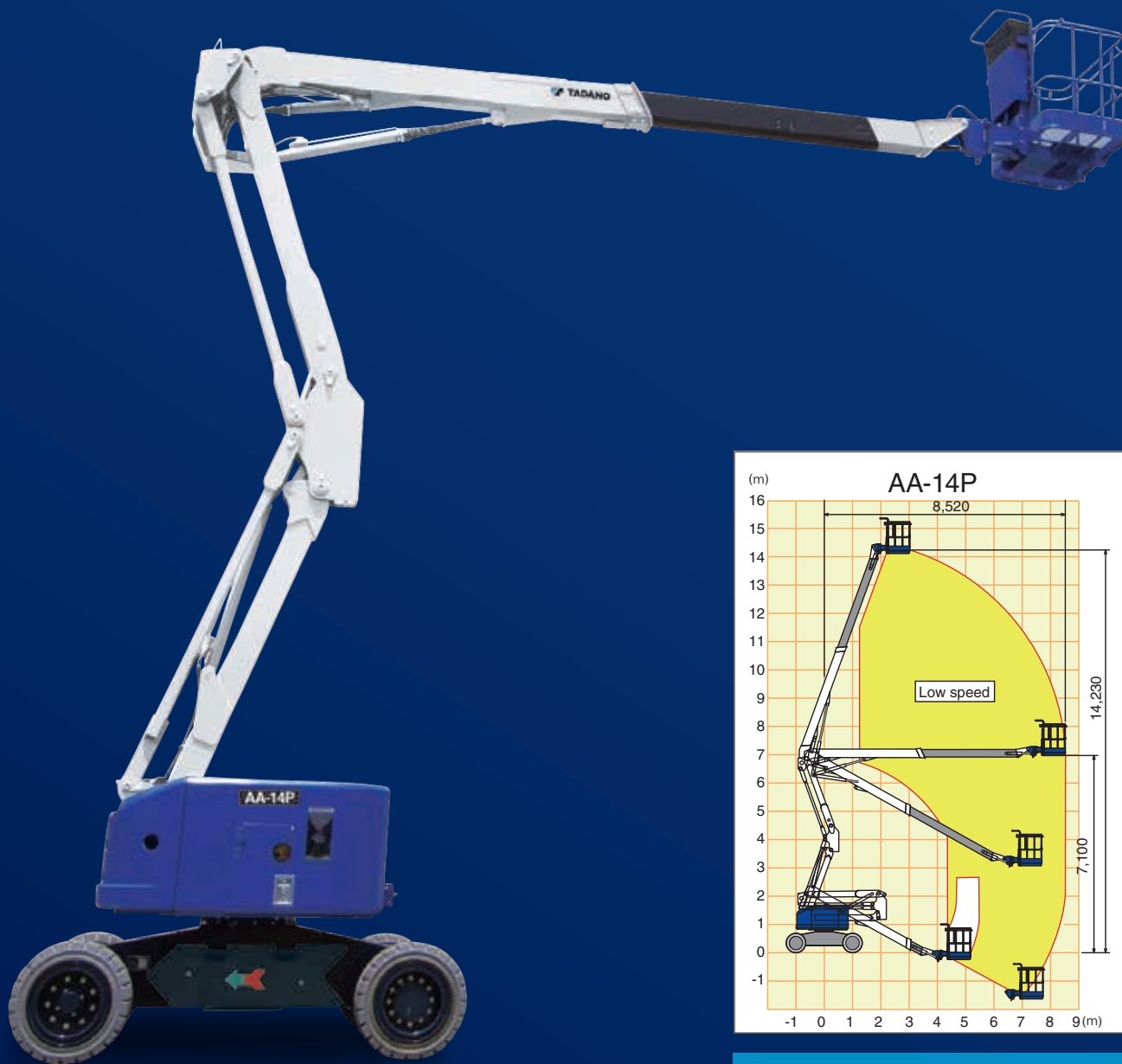

Model	AA-14P
Max. platform capacity	200 kg
Platform size (L x W x H)	1,130 x 730 x 1,000 mm
Max. platform height	14.2 m
Max. outreach	8.5 m

Model		AA-14P
<b>SPECIFICATIONS</b>		
Max. platform height	14.2 m	
Max. outreach	8.5 m	
Allowable tilt	3°	
Max. platform capacity	200 kg	
Platform size (L x W x H)	1,130 x 730 x 1,000 mm	
Platform rotation	L90° ~ R45°	
Transport dims (L x W x H)	6,740 x 1,980 x 2,330 mm	
Machine weight*	6,980 kg	
Main boom length	4.96 m ~ 7.85 m	
Elevation	-28.7° ~ 70.0°	
<b>TRAVEL</b>		
Travel speeds	0.9 / 3.0 / 5.0 km/h	
Max. ground pressure	881 kPa	
Travel position ground pressure	528 kPa	
Max. gradeability	17.6% (10°)	
Turning radius outside	4.69 m	
<b>POWER SOURCE</b>		
Engine type	KUBOTA D1105	
Rated power	14.4 kW / 2,400 min <sup>-1</sup>	
Fuel tank capacity	41 L	
<b>SAFETY DEVICES</b>		
Emergency stop	✓	
Foot switch / Enabling switch	✓	
Preventive malfunction device (at engine start)	✓	
Auxiliary lowering control	✓	
Traveling restriction (on slope)	✓	

\* Machine weight includes specified value of fuel, lubricating oil, hydraulic oil, and coolant.

### DIMENSIONS (mm)

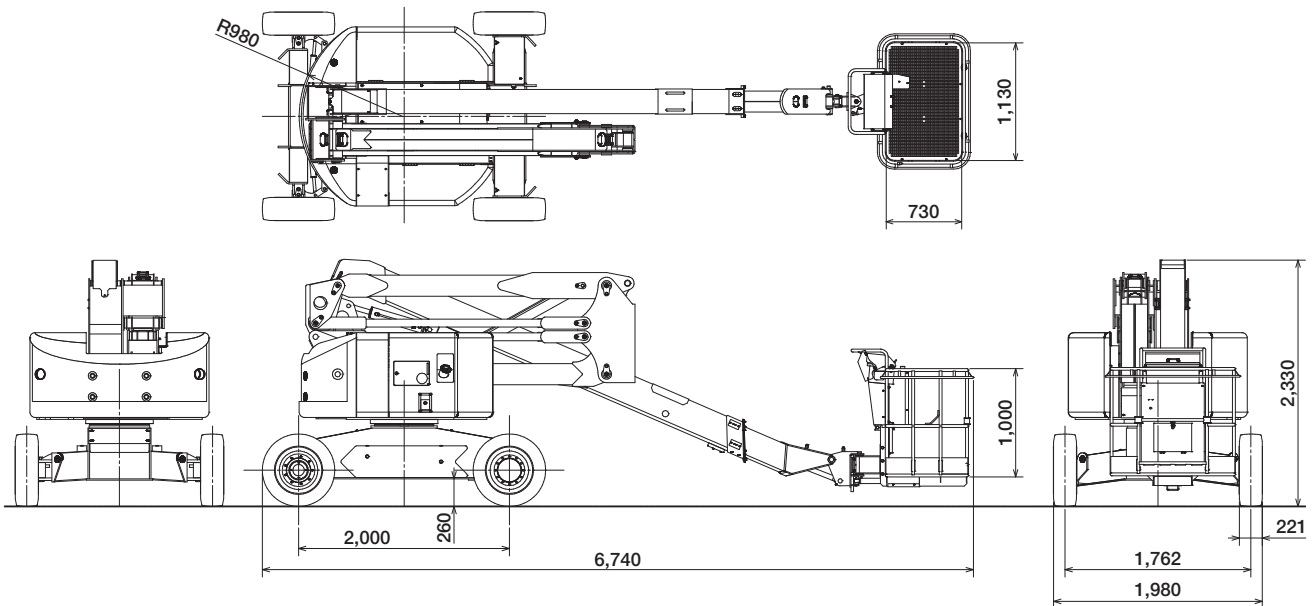

For all our types:



January 2026. Unless otherwise specified, all information in this brochure refers to a standard equipment, and it is intended as general information only. No liability is assumed. Errors reserved. Product specifications and prices are subject to changes without notice. The photographs and/or drawings in this brochure are for illustrative purposes only. For correct and safe operation, the original operating manual and lifting capacity charts are essential. Failure to follow the corresponding Operator's Manual when using our equipment or failure to otherwise act responsibly may result in property damage, serious injury or death. The sole warranty applicable with respect to our equipment is the standard warranty as per general terms and conditions of sales and service (ask your local Tadano dealer for details), and Tadano makes no other warranty, express or implied. All rights reserved. Any use of the trademarks, logos, brand names and model names used herein is prohibited.

**Tadano Ltd.**

Kanda Square 18th Floor, 2-2-1 Kanda-Nishikicho, Chiyoda-ku, Tokyo 101-0054, Japan  
 Phone: +81-3-6811-7309  
 info@tadano.com www.tadano.com

Reaching new heights