

OIL & STEEL



scorpion 16 - 16 Pro on Isuzu M21T

ENG



OIL & STEEL
AERIAL PLATFORMS

Truck-mounted aerial platforms / Scorpion 16 - 16 Pro on Isuzu M21T

Work area

Scorpion 16

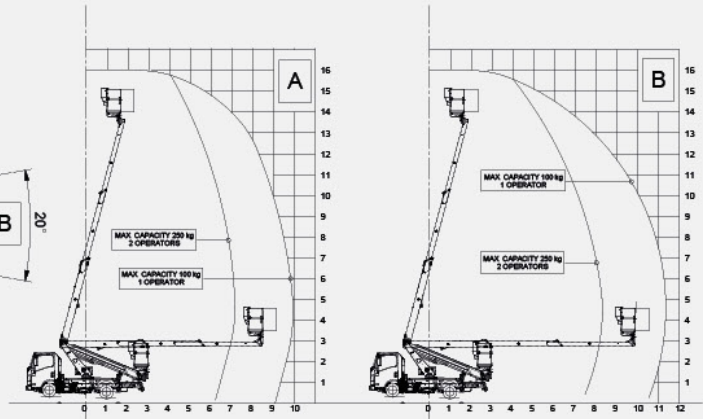
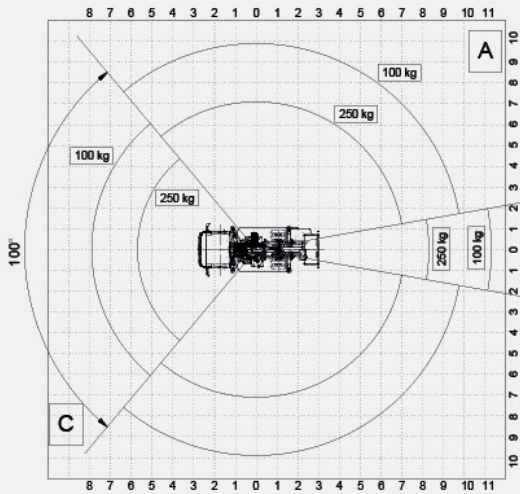

Scorpion 16 Pro

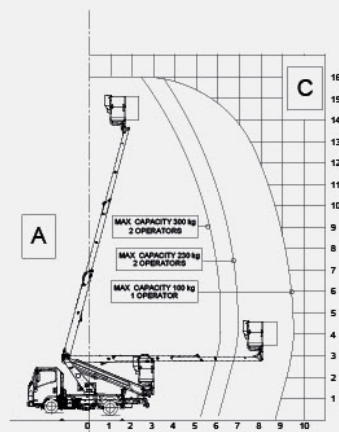
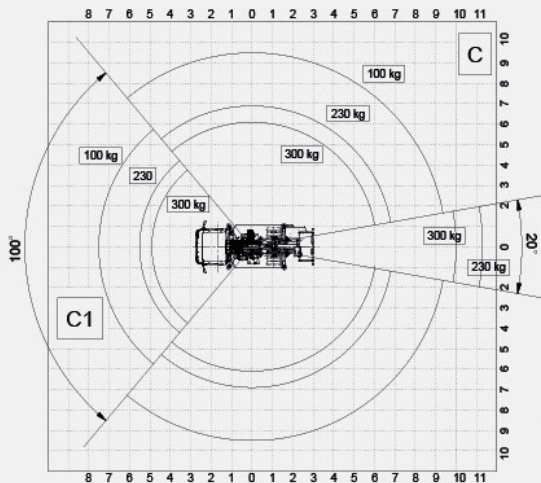
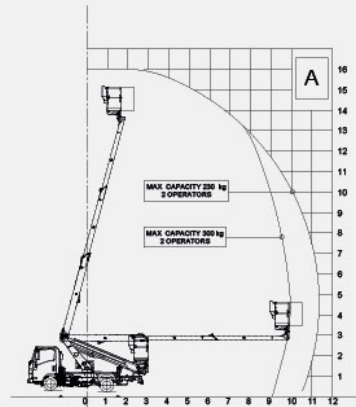
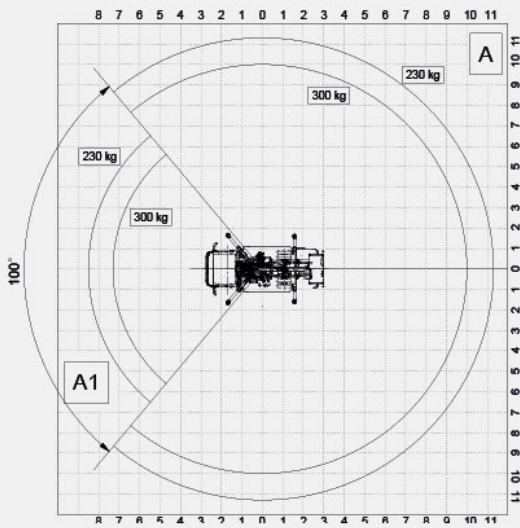

Technical drawings

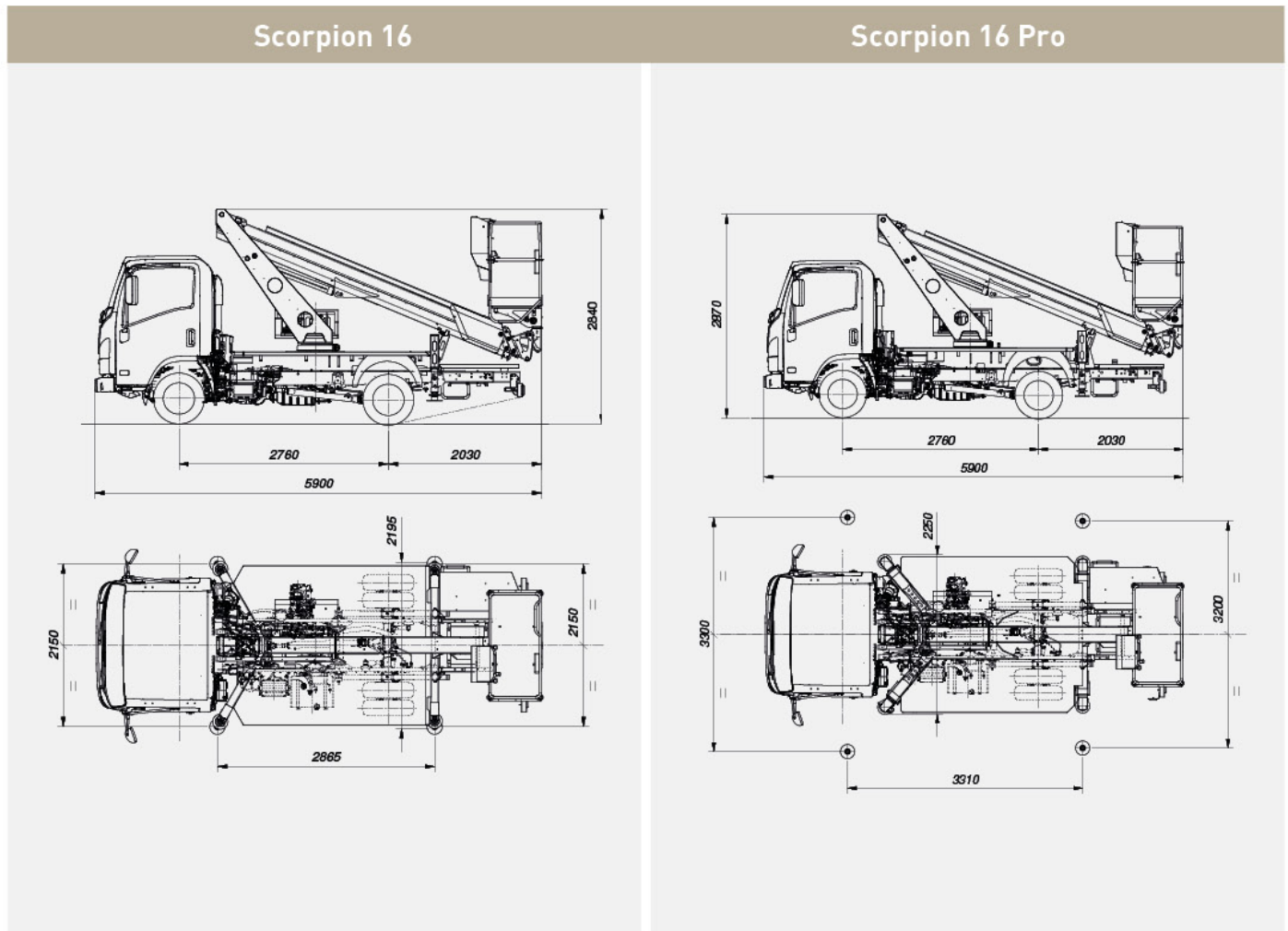

Technical features

SCORPION	16	16 Pro
Max working height	16 m	16 m
Max outreach	11.3 m	11.3 m
Max basket capacity	250 kg	300 kg
Basket	Alu 1.4 x 1.1 x 0.7 m	Alu 1.4 x 1.1 x 0.7 m
Controls	Hydraulics	Hydraulics
Turret rotation	400°	400°
Basket rotation	+/- 90°	+/- 90°
Outriggers	H - H	HE - HE
Machine length	5900 mm	5900 mm
Machine height	2840 mm	2870 mm
Machine width	2195 mm	2250 mm

Truck standard features

ISUZU M21T Euro 6d P. 2760 mm 1898 cm3 ENGINE - 120 CV
Adjustable steering wheel (tilt and height)
Power windows
Manual headlamp leveling system
Automatic headlight lighting
Front and rear fog lamps
Central Locking with remote control
Sun visor (driver's seat)

Aerial platform standard equipment

SCORPION	16	16 Pro	SCORPION	16	16 Pro
Boom and platform treated using corrosion-resistant paint, screws in stainless steel	✓	✓	Outriggers hydraulic controls	✓	✓
Standard painting white ral 9016	✓	✓	Lock valves on all cylinders	✓	✓
Power takeoff with electrical start-up and automatic release	✓	✓	Hydraulic circuit maximum pressure valves	✓	✓
Power takeoff on with no handbrake warning siren	✓	✓	Hydraulic extension of crossbeams	NA	✓
Power takeoff hour counter fitted on the dashboard of the vehicle	✓	✓	Work with asymmetrical crosspieces	NA	✓
Warning lights on the hour counter inside the cabin showing pto on and when outriggers are outside the vehicle profile	✓	✓	Hoses and cables inside the booms	✓	✓
Automatic start-up and shutdown of the main engine from the basket and from the column	✓	✓	Crossbeams extension-retraction block when platform is stabilized	NA	✓
Engine emergency stop button from the basket and from the column	✓	✓	Work on shape	✓	✓
Single-phase, 220 or 110 v ac power socket and differential overload switch fitted on the basket	✓	✓	Truck cabin anti-collision system	✓	✓
Thermal protection on the electrical system	✓	✓	Two-person aluminum basket with dimensions 1400 x 1100 x 700 mm	✓	✓
Moment detection and limiting system	✓	✓	Hydraulic rotation of the basket 90° right - 90° left with rotating actuator	✓	✓
Hand pump for emergency descent	✓	✓	Protective casing on the control box on the column and on the basket	✓	✓
Aerial part hydraulic controls	✓	✓	Anti-slip aluminum decking	✓	✓

Optional

Air conditioning system
Truck cabin painting different from standard
Aerial part painting different from standard
Customized labels
Remote connectivity kit
Tilt sensor
12V DC socket on the basket
12V DC socket + Working light 60W on basket
Electrical pump 12 V DC 1.6 kW for emergency descent
Auxiliary single-phase 220 V AC - 2.2 kW electrical pump (electrical control panel and battery charger powered by an external source)
Auxiliary single-phase 110 V AC - 2.2 kW electrical pump (electrical control panel and battery charger powered by an external source)
Magnetic 12 V revolving orange light for truck cabin
Magnetic 12 V revolving blue light for truck cabin
12V amber light rotating beacons for truck cab + bar
12V amber light rotating beacons for truck cab + bar + triangle
Fiberglass basket 1400 x 700 x 1100 mm (instead of standard)
Fiberglass basket 1400 x 700 x 1100 mm + insulation 1 KV (instead of standard)
Air-water line supply to the basket
Kit 4 nylon outrigger plates
Kit 2 harnesses
Junction debris protection kit
Inox toolbox with dimensions 500 x 350 x 350mm
Plastic toolbox with dimensions 480 x 400 x 400mm placed under the deck
Wheel chocks
Underride guards
Underride guards with plastic toolbox (only if plastic toolbox is included as optional)
Red and white reflective decals on truck
Fixed aluminum side panels 100mm / 150 mm / 200 mm height
Drop-down panels on 1 side (right) - 100 mm / 150 mm / 200 mm height
Drop-down panels on 2 sides - 100 mm / 150 mm / 200 mm height
Reduced capacity oil tank (40L)

* In case of fiberglass basket, data and performances may vary than indicated in this document.



PM OIL&STEEL SPA
S. Cesario sul Panaro
IT - 41018 - Modena
Via G.Verdi, 22

Tel.: +39 059 936811
Fax: +39 059 936800

info@oilsteel.com
www.oilsteel.com



Oil&Steel is a brand of Manitex International